

INTERWEAVE KNITS

FALL 2011
interweaveknits.com

*Fall
into place*

22

CLASSICS
TO **KNIT**
RIGHT NOW

DISCOVER
& CREATE

Ethereal Lace
Chunky Cables
Rustic Colorwork

Courtney Kelley
& Kate Osborn
**Get to know
the fiber life**

more
Double Knitting EXPLAINED



MADELINETOSH

with love

VISIT OUR WEBSITE FOR FREE PATTERNS AND COLOR INSPIRATION WWW.MADELINETOSH.COM

7515 Benbrook Pkwy, Benbrook, TX 76126 // (817) 249-3066



contents

Interweave Knits • FALL 2011 • VOLUME XVI • NUMBER 3

FEATURES

10 Bookshelf: Knitting Traditions

Clara Parkes *Uncover some knitting history*

14 Yarn Review: The Very Stuff

Interweave Knits Staff *Shetland and Shetland-style yarns*

16 Beyond the Basics: Extreme Double-Knitting

Alasdair Post-Quinn *Where can double-knitting go?*

22 Profile: Kate and Courtney on Courtney and Kate

Courtney Kelley and Kate Gagnon Osborn

A conversation about inspiration

PROJECTS

The Elements of Knitting

26 Cardiff Coat

Jennifer Wood *Instructions page 34*

28 Pembroke Wrap

Andrea Rangel *Instructions page 37*

29 Bryn Mawr Skirt

Nancy Eiseman *Instructions page 40*

30 Snowfall Sweater

Jill Draper *Instructions page 42*

31 Strobilus Pullover

Rachel Erin *Instructions page 46*

32 Shadow Tuque

Lee Juvan *Instructions page 48*

33 Cardigan Bay Jacket

Carol Feller *Instructions page 50*

Knitting Interrupted

54 Solstice Jacket

Larissa Gibson *Instructions page 60*

56 Gemini Cardigan

Katya Frankel *Instructions page 62*

58 Honeycomb Jacket

Laura Grutzeck *Instructions page 66*

Book Excerpt: Vintage Modern Knits

72 Flanders Bay Pullover

Kate Gagnon Osborn

All in a Golden Afternoon

76 Dahlia Cardigan

Heather Zoppetti *Instructions page 82*

78 Hex Mesh Stockings

Rebecca Blair *Instructions page 86*

80 Fern Lace Stole

Mareike Sattler *Instructions page 92*

80 Wheeled Lace Shawl

Kristin Omdahl *Instructions page 96*

The Teleidoscope Turns

98 True North Mittens

Odessa Reichel *Instructions page 108*

100 Rio Capelet

Sandy Cushman *Instructions page 110*

102 Angel Fire Jacket

Lisa Shroyer *Instructions page 112*

104 Canyon Cardigan

Eunny Jang *Instructions page 118*

104 Border Socks

Mary Jane Mucklestone *Instructions page 122*

106 Varsity Stole

Annie Modesitt *Instructions page 124*

107 Kelmscott Throw

Ann McDonald Kelly *Instructions page 126*

DEPTS

4 Strands

7 News and Views

130 Glossary

133 Sources for Supplies

142 Advertisers' Index

143 Project Index

144 Ravelings

Mary Kaiser

On the Cover: Cardiff Coat, page 26.

Photography by Carmel Zucker

THERE'S ALWAYS MORE ONLINE ... @ interweaveknits.com



Heather Zoppetti's DAHLIA CARDIGAN is a fascinating sweater that takes cues from traditional doilies and afterthought heels and adds a dash of modern style. Learn how to customize it to fit and flatter you in a brand-new sweater workshop.

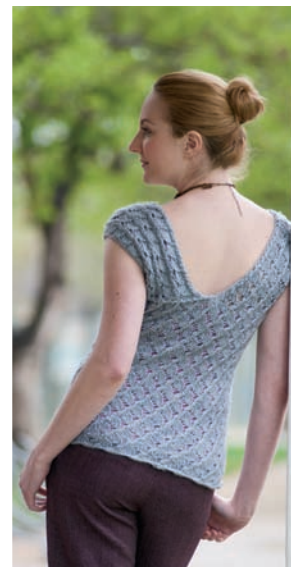

Real projects. Real knitters.
Follow along as real knitters make and modify patterns in exclusive project diaries.



See every project in detail: Click through to see stitch patterns, back views, and much more.

Colorwork is all over this issue! Find out everything you need to know about holding and managing your yarns, keeping track of your pattern, and cutting steeks with exclusive video how-tos.



Where Life Meets Knitting: Join the knittingdaily.com online community for great technique discussions, editor blogs, reader videos and galleries, patterns, forums, and insider information on each issue of *Interweave Knits* and other Interweave publications.

Go online for full schedules and local listings for *Knitting Daily TV!* Go to knittingdailytv.com for free projects, tips, designer spotlights, and exclusive bonus videos plus an all-new behind-the-scenes blog from the producers.

 **Tahki Yarns**

MONTANA
CEDARWOOD JACKET
FROM POTPOURRI COLLECTION



Now MONTANA comes
in solids, prints and new
super-bulky BIG Montana

sign up for free
monthly newsletter

www.tahkistacycharles.com/iwkf11



We knitters, we know that

time and *season* are fluid concepts. It might be August, but we're already dreaming of cool, crisp October. It might be ninety degrees in the shade, but we're digging through baskets of wool and breaking out our cable needles. We need to prepare—knitting a sweater doesn't happen in a weekend, so we'll take that head start on fall cardigans and pullovers, thank you very much. Mitten knitting over a slice of peach pie—what could be more natural?

In this Fall issue of *Interweave Knits*, we've gathered ideas for knits that work for every week of the fall—light, lacy pieces for warm September days that mellow into chilly evenings (“All in a Golden Afternoon,” page 76);

rustic colorwork for harvest fields (“The Teleidoscope Turns,” page 98); bold stitch work in big yarns for when the weather turns downright cold (“The Elements of Knitting,” page 26). And we've got three simple little layering pieces just right for wearing as cardigans or jackets (“Knitting Interrupted,” page 54). We've got you covered—literally.

And along with juicy knitting projects, we're exploring techniques, fibers, and designers' studios in this issue: Turn to page 16 to rediscover double knitting with Alasdair Post-Quinn in “Extreme Double-Knitting;” learn something new about Shetland wool in “The Very Stuff” (page 14); and come into the studio with the owners of Kelbourne Woolens in “Kate and Courtney on Courtney and Kate,” page 22. Our knitting adventures are taking us far afield this season.

So sit down, flip through this issue, and get inspired to make something new—fall will be here before you know it.

Happy Knitting,

Eunny

P.S.

A GIANT THANK YOU to the Farm at Lee Martinez Park in Fort Collins, Colorado, James and the Little Bird Bakeshop (www.thelittlebirdbakeshop.com), and to RealTec Commercial Real Estate for all their help with this issue.

Pembroke Wrap, page 28



EDITORIAL

EDITORIAL DIRECTOR Karin Strom
 EDITOR Eunny Jang
 MANAGING EDITOR Allison Mackin
 ASSISTANT EDITOR Larissa Gibson
 PROJECT EDITOR Joni Coniglio
 EDITORIAL ASSISTANT Kathy Mallo
 TECHNICAL EDITORS Therese Chynoweth, Karen Frisa,
 Lori Gayle, Peggy Greig, Dee Neer,
 COPY EDITOR Veronica Patterson

CREATIVE SERVICES

SENIOR DESIGNER Kit Kinseth
 PRODUCTION DIRECTOR Trish Faubion
 PRODUCTION COORDINATOR Dean Howes
 PRODUCTION EDITOR Nancy Arndt
 PHOTOGRAPHY
 PROJECTS Carmel Zucker
 DEPARTMENTS Larissa Gibson
 PHOTOSTYLING Pam Chavez
 HAIR & MAKEUP Kathryn MacKay
 ILLUSTRATION Gayle Ford, Marjorie Leggett
 VIDEO MANAGER Garrett Evans

PUBLISHING

GROUP PUBLISHER John P. Bolton
 MEDIA SALES DIRECTOR Julie Macdonald
 ADVERTISING MANAGERS Marcy Bradford, Diane Kocal
 AD TRAFFICKERS Melissa Marie Brown, Tina Rolf
 CLASSIFIED ADVERTISING Stephanie Griess
 MARKETING DIRECTOR, FIBER DIVISION Mary Kincannon
 MARKETING MANAGER Annie Hartman Bakken
 SVP CONSUMER MARKETING Bob Kaslik
 CIRCULATION MANAGER Jodi Smith
 CONSUMER MARKETING BUSINESS MANAGER Tammy Gorham
 BUSINESS MANAGER, FIBER DIVISION Dawn Stewart

Projects and information are for inspiration and personal use only. We've made every effort to ensure the accuracy of the contents of this publication. However, human errors do occur. If you have questions regarding a pattern in this issue, please visit us online at www.interweaveknits.com/corrections.

Interweave Knits does not recommend, approve, or endorse any of the advertisers, products, services, or views advertised in *Knits*. Nor does *Knits* evaluate the advertisers' claims in any way. You should, therefore, use your own judgment in evaluating the advertisers, products, services, and views advertised in *Knits*.

Interweave Knits (ISSN 1088-3622) is published quarterly by Interweave Press LLC, 201 E. 4th St., Loveland, CO 80537-5655. (970) 669-7672. USPS #017-249. Periodicals postage paid at Loveland, CO 80538, and additional mailing offices. All contents of this issue of *Interweave Knits* are copyrighted by Interweave Press LLC, 2011. All rights reserved. Projects and information are for inspiration and personal use only. Reproduction in whole or in part is prohibited, except by permission of the publisher. Subscription rate is \$26.95/one year in the U.S., \$30.95/one year in Canada, and \$33.95/one year in international countries (surface delivery). U.S. funds only.

POSTMASTER: Please send address changes to Interweave Knits, PO Box 469117, Escondido, CA 92046-9117.

Visit the Interweave website at interweave.com. For advertising information, call Julie Macdonald at (970) 613-4612, email jmacdonald@interweave.com, or visit the website at interweave.com. For sales information, call (800) 272-2193, email sales@interweave.com. For editorial inquiries, call (800) 272-2193, email knits@interweave.com, or write to 201 E. 4th St., Loveland, CO 80537-5655.

Retailers: If you are interested in carrying this magazine in your store please call (866) 949-1646, email sales@interweave.com, or visit www.interweaveretailer.com.



FOUNDER
Linda Ligon

CEO
Clay B. Hall

CFO
Troy Wells

SENIOR VPS
John P. Bolton
Bob Kaslik
Stephen Koenig

VP, EVENTS & EDUCATION
Sara Dumford

VP, PEOPLE OPERATIONS
Aaron Wilmot

VP, PRODUCTION
Trish Faubion

VP, TECHNOLOGY
T.J. Harty

MAGAZINES

Fiber Division
Cloth, Paper, Scissors
Handwoven
Interweave Crochet
Interweave Knits
PieceWork
Quilting Arts
Spin-Off

ONLINE

Knitting Daily
EDITOR
Kathleen Cubley

BOOKS

PUBLISHER
Stephen Koenig
EDITORIAL DIRECTOR
Marlene Blessing
ACQUISITIONS EDITOR
Allison Korleski
ART DIRECTOR
Liz Quan
PRODUCTION DIRECTOR
Kristen Heller
For questions regarding our book program, call (970) 669-7672 Monday–Friday, 8:00 A.M.–5:00 P.M., or email books@interweave.com



ASPIRE
MEDIA

An Aspire Media company

SUBSCRIBERS: Have a question about your *Interweave Knits* subscription? We have the answer. Visit our website, email, call, or fax your question, and we'll be happy to assist you. Go to interweaveknits.com and click on *Subscribe* for new subscriptions, renewals, gift orders, and to change your address, pay your bill, and to submit subscription questions or concerns.

Interweave Knits Subscription Services
Email address: interweaveknits@pcspublink.com
U.S. & Canadian Customer Service: (800) 835-6187
International Customer Service: (760) 291-1531
Fax number: (760) 768-4805
Mail: PO Box 469117, Escondido, CA 92046-9117

Please allow six weeks for processing address changes. Your customer number on the address label is your key to the best service possible. Please include it with all correspondence to avoid delays or errors.

Interweave Press LLC Main Office
201 East Fourth Street • Loveland, Colorado 80537 • (970) 669-7672

Visit our website interweaveknits.com



Berroco Voyage™ & Nanuk™

New for Fall '11. Voyage is an alpaca rich chainette yarn in refined heather shades. Its companion yarn, Nanuk, a plush textured yarn that begs to be touched.

 **BERROCO®**
www.berroco.com

caffé knit in Voyage™ & Nanuk™ from Booklet #314

For details, go to www.berroco.com and enter "caffé" in our search box.

Hello, my name is **addi** .
Allow me to introduce myself...



What is your **addi** ction?



Meet this **addi**ct at:
www.skacelknitting.com

- ✓ Smooth joins that don't snag
- ✓ Soft, pliable cords
- ✓ Lifetime guarantee
- ✓ **addi** - *family owned and handmade since 1829!*



Make small repairs and cut yarn and thread ends with these go-everywhere *Classic Embroidery Scissors* (G-4) from Gingher. www.gingher.com



For major alterations, Gingher's 8" *Spring-Action Dressmaker's Shears* (G-8SA) make cutting through thick sweaters a breeze. www.gingher.com

Learn to identify and fix many common knitting mistakes with the handy reference *Knit Fix* by Lisa Kartus (Interweave, 2006).

NEW AND NOTABLE
Save Our Stitches
 Doctor, mend, and alter your knits.



Pick up dropped stitches with ease in both knit and purl directions using *Fix-A-Stitch*. www.fixastitch.com



Not a fan of darning? Try needlefelting to repair small holes in inconspicuous places. These *multineedle holders* from Felt Crafts will make short work of mending. www.feltcrafts.com

Darning needles are the workhorses of knitting repairs. Keep a set of your favorites in every conceivable knitting location.



Lovely wooden *darning eggs* from Magpie WoodWorks make required tasks more interesting. www.magpiewoodworksusa.com



About to start a tricky section of knitting and need a lifeline? Try a small circular needle instead. Simply insert it through every stitch of the current row and leave the needles hanging on those stitches. If you need to rip back, everything below that row will be preserved on the "lifeline" circular.



yarn spotlight



< SIMPLE AND SWEET

We knitters are often drawn to a yarn by its intoxicating color, but an undyed yarn can also lure us with its simple and elegant beauty. Such is the case with Yarnundyed, a line of yarn manufactured in Bradford, England, and recently made available in North America by Pollika. Pictured here are two examples: Chunky Weight Baby Alpaca (100% baby alpaca) and 4-ply Superwash Bluefaced Leicester (100% British Bluefaced Leicester wool). Use these undyed yarns as a canvas for your own dyeing and handpainting projects or just as they are; either way, their delightful fibers and superb construction are sure to please.

www.pollika.com

product spotlight

SWIFT SOLUTIONS

In a bygone picture of domestic bliss, a knitter and child sit by the hearth, the child dutifully holding a skein between outstretched arms while the knitter winds a ball of yarn. Where did those children go? At least a good swift won't abandon you to play video games.

Glimakra, a Swedish loom manufacturer, makes a grand version of the traditional umbrella swift. The large swift will expand to hold any skein up to 100" in circumference. Expertly finished to hold the yarn without slipping or snagging, this swift will stand in for generations of little helpers.

www.glimakrausa.com



The less familiar Japanese design of the Schacht Goko Metal Swift will also hold most commercial skeins. The recommended range is 57–64" in circumference, but the swift will also work with slightly larger skeins. The lightweight cage and vertical orientation minimize resistance to make it particularly well suited for fine and delicate yarns. For the smoothest unwinding, Schacht recommends pulling the yarn from the bottom of the wheel.

www.schachtspindle.com



make time for yarn every day



Connie Chang Chinchio is a knitter's knitter—her designs explore just how far knits and purls can go when rearranged. Focusing on body-friendly, feminine silhouettes, her sweaters are a unique blend of traditional techniques and everyday wearability.



- ❖ Check out Connie's gorgeous designs in *Interweave Knits*, on knittingdaily.com, and at interweavestore.com (above left: Farmer's Market Cardigan, *Interweave Knits*, Fall 2009; above right: Printed Silk Cardigan, *Interweave Knits*, Spring 2008).
- ❖ Get more of Connie's patterns, design notes, and technique tips than ever in her new book *Textured Stitches* (Interweave, 2011).
- ❖ Learn how to work some of the twisted-stitch techniques Connie loves in *Knitting Daily TV Episode 607*. Check knittingdaily.tv.com for airtimes in your area.



blue
sky
ALPACAS™

blueskyalpacos.com

©2011 Blue Sky Alpacas

Autumn Vest
Bulky | 1001 lynx



CLARA PARKES

Knitting. The mere word conjures up images of the past—comforting, but sometimes frustrating for those of us who wish to be seen as we are today. Yet there’s no denying our reverence for our knitting predecessors and our curiosity about how and what these people knit. Several new and older books attempt to reconcile the past with the present, cataloging the techniques of our knitting forebearers, telling their stories, and helping us re-create their works on our own needles.

Larissa Brown celebrates the generational aspects of knitting in her new book, *My Grandmother's Knitting: Family Stories and Inspired Knits from Top Designers* (STC Craft/A Melanie Falick Book, 2011)—a play on the “not your grandmother’s knitting” cliché that’s been paraded out in articles and press releases over the last decade. Brown traces the creative lineage of some of our best-known designers, from Meg Swansen and Pam Allen to Ysolda Teague, Norah Gaughan, and Jared Flood. She tells of mothers, fathers, aunts, grandmothers, and grandfathers who sparked each designer’s creative tendencies. The profiles are followed by twenty-one projects, some by the designers profiled, others not. Most were conceived directly or indirectly with a nod to a person or place that stands out in the designer’s memory.

Sometimes the creative legacy can come from a stranger, as happened when the one-hundred-year-old lace-knitting notebook of Blanche Beau was discov-

ered in a Sacramento attic and entrusted to Nancie Wiseman. She took on the painstaking task of deciphering Blanche Beau’s swatches and charts, which she presents in her book *Lace from the Attic: A Victorian Notebook of Knitted Lace Patterns* (Interweave, 1998). In addition to being a solid reference on knitted lace, it’s also a lovely story about the woman, brought to California by her French immigrant parents during the Gold Rush, who so loved knitting it.

Our knitted legacy can also take the shape of a particular garment or stitch, as evidenced by the colorful tradition of Fair Isle knitting. *Alice Starmore's Book of Fair Isle Knitting*—thankfully reprinted by Dover Books in 2009—is arguably the most comprehensive reference on the subject. Starmore writes about the history, traditions, and specific techniques involved in Fair Isle knitting, in addition to sharing a stunning selection of color combinations and charted patterns.

Fair Isle of Scotland is just one of many regions of Europe with a rich textile legacy. James Norbury’s *Traditional Knitting Patterns: from Scandinavia, the British Isles, France, Italy, and Other European Countries*, originally published by Dover in 1973, offers a survey of regional knitting techniques, traditions, stitch patterns, and motifs. As he presents a broad range of traditions, he also offers a look at the roots of each tradition and the likely origins of knitting within the Arab world.

For avid knitting historians, the words “knitting around the world” have meant one book only: the slender paperback by the same name from *Threads* magazine. Now a collector’s item, *Knitting Around the World* (Taunton, 1993) contains classic historic research and technique information written by the likes of Meg Swansen, Alice Starmore, Maggie Righetti, Beth Brown-Reinsel, and Montse Stanley.

But a new *Knitting Around the World* exists, this one from Lela Nargi and bearing the subtitle *A Multistranded History of a Time-Honored Tradition* (Voyageur Press, 2011). Like its predecessor, the book aims to capture knitting history, traditions, and techniques from places far and near. Nargi travels the globe from England to Estonia, Iceland to Japan, Peru to Bolivia, and Canada to the United States. In addition to profiles of twenty historically significant contemporary knitters, the book also has twenty patterns that reflect the diversity with which we’ve embraced knitting technique and tradition around the world.

When she doesn’t have her nose in a book or a skein of yarn, *Clara Parkes* publishes her weekly online knitting magazine, www.knittersreview.com. She is also the author of *The Knitter's Book of Yarn* and *The Knitter's Book of Wool* (Potter Craft, 2007 and 2009 respectively), and her newest release, *The Knitter's Book of Socks* (Potter Craft, 2011).



Knitting Wildlife

S A B R I N A G S C H W A N D T N E R



#5 Ocelot, 2010. Size: 53" × 32"
Handknitted textile. Interpretation of ocelot based on study of actual pelt at American Museum of Natural History. Male, collected from Peru 1930. Yarn, string, sticks.

When Australian artist **Ruth Marshall** graduated from Pratt Institute's MFA sculpture program in 1995, she needed to find work in her field of study to extend her visa. She got a job as an exhibit artist at the Bronx Zoo, where she spent her breaks busily knitting socks. One day her boss asked her to repaint a Gaboon viper sculpture and jokingly suggested she knit it. "A light bulb went off in my head," Marshall says. "He was absolutely right! The Gaboon viper has a very colorful diamond-shaped pattern, completely translatable to the texture of knitting."

Since then, Marshall has been knitting animals that have vivid, challenging patterns. Her process is time intensive: first she takes two to three weeks to create an intarsia knit pattern based on photographs or animal pelts at the American Museum of Natural History. Then, using natural yarns—usually either 100 percent wool or

cotton—she knits the pattern over a two- to three-month period. She has replicated all sixty-eight species of coral snake and is currently working on a series of knitted tigers.

Her works are so finely detailed that from a distance they look like actual animal forms. "Peoples' first reaction is one of horror," the artist explains. "Animal pelts are repugnant to many people, and rightly so. When viewers realize that the piece is knitted, there is an adjustment in their reaction, and they can engage in appreciating how beautiful these animals are. After going on this journey, the conversation can turn to conservation and how important it is to try and save endangered species." Marshall hopes to sell her work and give a percentage of the earnings to wildlife organizations dedicated to saving wild animals. ■

For more information, please visit www.ruthmarshall.com.

Sabrina Gschwandtner is a New York-based visual artist and author of *Knitknit: Profiles and Projects from Knitting's New Wave* (Stewart, Tabori & Chang, 2007).



MANOS DEL URUGUAY



COLORADO

Find Your Stash | Castle Rock | 303-660-9276 | fystash.com
Shuttles, Spindles, & Skeins | Boulder | 800-283-4163 | shuttlespindlesandskeins.com

CONNECTICUT

Nancy O | Ridgefield | 203-431-2266 | shoppnancyo.com

FLORIDA

A Good Yarn | Sarasota | 941.487.7914 | agoodyarnsarasota.com

ILLINOIS

The Fold | Marengo | 815-568-5730 | thefoldatmc.net
Three Bags Full | Northbrook | 847-291-9933 | threebagsfullknittingstudio.com

INDIANA

Sheep Street Fibers | Martinsville | 812-597-KNIT | sheepstreet.com

MASSACHUSETTS

A Good Yarn | Brookline | 617-731-4900 | agoodyarn.biz
Cranberry Fiber Arts | S. Hamilton | 978.468.3871 | cranberryfiberarts.com
Knit Purl | Sudbury | 978-443-5648 | knitpurlsudbury.com
Windsor Button | Boston | 617-482-4969 | windsorbutton.com
Wonderful Things | Great Barrington | 413-528-2473 | wonderful-things.com

MARYLAND

All About Yarn | Columbia | 410-992-5648 | allaboutyarn.com
Cloverhill Yarn Shop | Baltimore | 410-788-7262 | cloverhill yarn.com
Ewenique Yarns | Bel Air | 410-399-9929 | eweniqueyarns.com



ARKANSAS

Hand Held | Fayetteville | 479-582-2910 | handheldknitting.com

CALIFORNIA

Alamitos Bay Yarn Co | Long Beach | 562-799-8484 | yarncompany.com
Anacapa Fine Yarns | Ventura | 850-654-9500 | anacapafineyarns.com
Ball & Skein & More | Cambria | 805-927-3280 | cambriayarn.com
Colors 91711 | Claremont | 877-659-1711 | colors91711.com
Knit & Pearl Boutique | Santa Barbara | 805-963-3930
Monarch Knitting & Quilts | Pacific Grove | 888-575-9276 | monarchknitting.com
Wild Fiber | Santa Monica | 800-382-7067 | wildfiber.com
Yarndogs | Los Gatos | 408-399-1909 | yarndogs.com



Wool Clasica - Silk Blend - Rittenhouse Merino 5-Ply - Serena - Maxima - Lace



OREGON

Stitchin' Post | Sisters | 541-549-6061 | stitchinpost.com
Websters | Ashland | 800-482-9801 | yarnatwebsters.com

PENNSYLVANIA

Mannings | E. Berlin | 800-233-7166 | the-mannings.com
Rosie's Yarn Cellar | Philadelphia | 215-977-9276 | rosiesyarncellar.com

RHODE ISLAND

Fresh Purls | Providence | 401-270-8220 | freshpurls.com
The Mermaid's Purl | North Kingstown | 401-268-3899 | themermaidspurl.com

VERMONT

Northern Nights | Norwich | 802-649-2000



MICHIGAN

Lost Art Yarn Shoppe | Traverse City | 231-941-1263

MINNESOTA

Amazing Threads | Maple Grove | 763-391-7700 | amazing-threads.com

MONTANA

Joseph's Coat | Missoula | 406-549-1419 | josephscoat yarn.com

NORTH CAROLINA

Earth Guild | Asheville | 800-327-8448 | earthguild.com

NEW HAMPSHIRE

Elegant Ewe | Concord | 603-226-0066 | elegantewe.com

NEW JERSEY

Knit-a-Bit | Westfield | 908-301-0053 | knit-a-bit.com
Woolbearers | Mt. Holly | 609-914-0003 | woolbearers.com

NEW YORK

Flying Fingers | Tarrytown | 877-359-4648 | flyingfingersyarnshop.com
Knit | Roslyn | 516-625-KNIT | knitlongisland.com
Purl | New York | 212-420-8796 | purlsoho.com

OHIO

The Yarn Shop | Columbus | 614.457.7836 | yarnshoponline.com



VIRGINIA

Aylin's Woolgatherer | Falls Church | 800-775-9665 | aylins-wool.com
Hunt Country Yarns | The Plains | 540-253-9990 | skeins.com
Knitting Sisters | Williamsburg | 757-258-5005 | knitting sisters.com
The Knitting Corner | Virginia Beach | 757-420-7547 | theknittingcorner.com
Uniquities | Vienna | 888-465-5648 | uniquenessyarnshop.com

WASHINGTON

Apple Yarns | Bellingham | 360-756-9992 | appleyarns.com
Seattle Yarn Gallery | Seattle | 206-935-2010 | seattleyarn.com

WISCONSIN

The Cat & Crow | Mount Horeb | 608-437-1771 | thecatandcrowonline.com



Fairmount Fibers Ltd.

www.fairmountfibers.com | info@fairmountfibers.com | 888.566.9970
In Canada: CNS Yarns Inc. | 514:276.1204 | info@cnsyarns.com | www.manoscanada.com



THE VERY STUFF

INTERWEAVE KNITS STAFF



In its own quirky way, wool from Shetland sheep is one of the original luxury fibers. Soft, fine, and warm, the yarn made from Shetland fleeces is the standard for glowing colorwork and whisper-fine lace.

The beautifully delicate wool produced by Shetland sheep is actually a happy accident. Native to the Shetland Islands north of mainland Scotland, Shetland sheep are short, stubby-legged and stubby-tailed little animals, hardy and adaptable grazers. Scrabbling for centuries among rocks and on heath, Shetland sheep have become efficient mobile factories for processing sunshine and

plants into milk, meat, and wool. They are a Landrace breed: adaptation and evolution have shaped them rather than human intervention and deliberate cross-breeding. But their fine, dainty fleeces—SmartWool’s ancient ancestor—believe their rough lives. Wool from Shetland sheep has been a valuable source of income—both as a raw material and as a part of value-added knitted goods—for Shetland crofters since medieval times. And, a revival of interest in preserving and spreading the breed in the late twentieth century has resulted in Shetland sheep becoming citizens of the world.

Shetland wool tends to be fairly fine, between 20 and 30 microns in diameter (for comparison, superfine cashmere ranges between 11 and 20 microns, and fine merino wools range between 15 and 25 microns). The finest wool tends to be found at the head and shoulders of the sheep; the wool found

toward the rear is coarser. Careful sorting sets the finest wool aside to become knitting yarn. Shetland wool spins easily and softly into an airy, bouncy yarn that gains much of its springy structure from the fine crimp of the component fibers and knits up into a warm, plush fabric. Best of all, Shetland sheep naturally produce wool in a palette of colors, from dark brown to russet to bright white, with infinite variations of shade and tint from animal to animal.

This review focuses on Shetland and Shetland-style wool knitting yarns intended for stranded colorwork—after all, Shetland wool’s myriad natural colors made it the original yarn for Fair Isle knitting. These yarns share a lofty, plush hand and woolen-style spinning’s softly blurred surface. Shetland wool is also available in weights meant for fine-lace knitting as well as larger-gauge projects.

Jamieson’s Shetland Spindrift

Content: 100% Shetland wool from the Shetland Islands • Put-Up: 115 yd [105 m]/25 g • Construction: 2-ply • Care: Handwash, dry flat • Recommended Gauge: 30 sts = 4" on size 3 (3.25 mm) needles

Jamieson’s Shetland Spindrift, along with Jamieson and Smith’s 2 Ply Jumper Weight, is one of the original Shetland knitting yarns. Jamieson’s was begun in the late nineteenth century as a knitwear broker, buying and selling knitted goods made by local crofters on Shetland. Eventually, the business grew to buying and selling raw wool for processing in mainland Scotland, and finally to buying, preparing, and spinning wool on Shetland itself in a specialized spinning mill. Today, Jamieson’s yarns are grown, shorn, washed, dyed, spun, and balled without ever leaving the Shetland archipelago.

With a relaxed and very slightly irregular twist, Shetland Spindrift knits up into gloriously fine colorwork that shows a painterly blending between color areas—a result of the wool’s fine hairy halo and the slight irregularity of the stitches. In the ball, the yarn feels plump and warm, with a flat plushness reminiscent of shorn velvet. Available in more than one hundred colors, including heathers and natural fleece shades, this yarn provides the vintage Shetland wool experience.

Jamieson and Smith 2 Ply Jumper Weight

Content: 100% Shetland wool from the Shetland Islands • Put-Up: 129 yd [118 m]/25 g • Construction: 2-ply • Care: Handwash, dry flat • Recommended Gauge: none given

Jamieson and Smith, in business for nearly a hundred years, also produces 100% pure Shetland wool knitting yarns. With a focus on sustaining and revitalizing Shetland’s crafting economy and preserving its rich textile traditions, Jamieson and Smith produces knitting yarns, ready-to-wear knitwear, and woven goods with Shetland wool purchased from local farmers.

2 Ply Jumper Weight is a classic Fair Isle yarn. With a slightly plumper, tighter twist than that of Shetland Spindrift, it knits up into a fabric with crisper definition and a substantial feel with no spaces between stitches. It feels more substantial in the ball, too, with spring and bounce that forgive uneven stitches. Available in nearly one hundred shades, 2 Ply Jumper Weight boasts beautifully deep, rich colors, with artfully blended heathery shades and clear, pure solids. Like Shetland Spindrift, it will meld and mat gently with itself as it is worked, resulting in a fabric with a very lightly felted, very warm feel.

Elemental Affects Natural Shetland Fingering

Content: 100% North American Shetland wool • Put-Up: 118 yd [108 m]/1 oz [28 g] • Construction: 2-ply • Care: Handwash warm, dry flat • Recommended Gauge: 28–32 sts = 4" on size 1 to 3 (2.25 to 3.25 mm) needles

Now we leave the Shetland Isles for Shetland wool grown elsewhere. Elemental Affects Natural Shetland Fingering is the result of a joint project between the company and master spinner Judith Mackenzie. Wool from Judith’s flock of Shetland sheep in Montana is processed and spun in the United States to create a rustic, delightful yarn with plenty of character.

This Shetland yarn is a little hairier and less refined than those from the big Shetland companies; it has a few longer hairs sticking out of the surface of the yarn here and there and a very slight irregularity in the twist that makes some sections a bit thinner and some a little plumper. It feels deliciously woolly, with a lightly toothed surface that can be knitted pleasantly and quickly by touch alone. The colors, too, are rich and intense—the varying fineness of the individual fibers in the yarn turns them into facets, reflecting the same colors back in slightly different ways.

This yarn is ideal for colorwork, knitting up into a flat, pleasingly fine fabric with lightweight drape and blending colors. It’s available in forty-two dyed colors as well as nine

natural shades, which change slightly every year with changing sheep.

Harrisville Designs New England Shetland

Content: 100% pure wool • Put-Up: 217 yd [198 m]/50 g • Construction: 2-ply • Care: Handwash, dry flat • Recommended Gauge: 26 sts = 4" on size 2 to 4 (2.75 to 3.5 mm) needles

The oddball in our bunch, New England Shetland, is actually a mixed-breed fine wool spun in the United States, not a yarn made from Shetland sheep. Its name comes from its usefulness in Shetland-style knitting and its remarkably Shetland-like hand and behavior. Ideal for colorwork, with its broad palette and classic 2-ply construction, New England Shetland has the same flat, cushy plumpness as pure Shetland wools—with an additional softness when knitting. Its sixty-four colors are all created by dyeing and then carding and spinning fleeces, resulting in softly heathered colors with lovely depth.

New England Shetland knits up at a slightly larger gauge than most Shetland jumper-weight yarns, blooming nicely to fill the spaces between stitches. If you’re dying to tackle a colorwork project, but aren’t relishing the thought of knitting eight or nine stitches to each inch, New England Shetland is a great choice.



Adapted from *Extreme Double-Knitting: New Adventures in Reversible Colorwork* by Alasdair Post-Quinn, to be published by Cooperative Press in 2011.

What is double-knitting?

I imagine the long-forgotten originator of double-knitting sitting by the fireside, holding a 1×1 ribbed scarf and idly pulling the fabric in one direction to separate the ribs, then in the other direction to recompress them. She looked it over on both sides and noticed that the compressed fabric strongly resembled stockinette stitch on both sides, to the point that she could imagine it as two independent fabrics lying back to back. She picked up her needles, pulled two ends from the basket of yarn at her side, and cast on. But this time, rather than ribbing, she held the ends together, and worked the knits in one color and the purls in the other. Thus, I imagine, double-knitting was born.

At its most basic, double-knitting really is that simple. The two sides of the fabric are actually separate, unless they are joined in some way during the work. Double-knitting can be worked in one color or two—or, as you will see later, in three or more colors. In two or more colors, you have the option to work reversible colorwork motifs, which hold the two sides of that tubular fabric together. Double-knitting is a unique addition to your repertoire that makes a fabric that can't be created in any other way.

Double-knitting stitches

These are the rules of standard double-knitting:

- All double-knitting is worked in pairs of stitches.
- The first stitch in the pair is always the facing-side stitch, is always knitted, and is always worked with all active ends in back (wyib).

Extreme Double-Knitting

ALASDAIR POST-QUINN

Photos by Shannon Okey

Vasily, in three-colored cabled double-knitting

- The second stitch in the pair is always the opposite-side stitch, is always purled, is always worked with all active ends in front (wyif), and is always worked in the opposite color from the facing-side stitch.

In truth, the rules are little more than guidelines. In the full book, we'll break a few of them, but they are the foundation on which the structure of double-knitting is built.

The structure of double-knit fabric

Double-knit fabric is comprised of two layers, worked simultaneously. In reality, you are knitting a layer of stockinette with a layer of reverse stockinette behind it. The end result is a fabric that appears to have no wrong side—the stockinette faces outward, while the purl sides of both layers face each other inside the work. If each side is a separate solid color, then the fabric is hollow—you can pinch each side and separate it. If you wanted, you could separate the layers before binding off and stuff the space with batting. However, if you change colors within a row, the two sides will lock together.

When color changes are included, you have the freedom to create motif patterns, all-over patterns, lettering—really, anything that can be charted. Any time a color is used on one side, its opposite color is used on the other side. This means that any two-color design can be double-knitted without worry about strand length. Likewise, any amount of space can be put between motifs without

worrying about wasting yarn. If it weren't for the double thickness, we would have just put Fair Isle and intarsia out of business. It also means that asymmetrical motifs will show up in mirror image on the opposite side.

Working in standard flat double-knitting

In *Extreme Double-Knitting*, I take you graphically through the cast-on I prefer, then teach you how to work in the flat—then in the round. In this format, however, I don't have the space to show all of the pictures. So let's simplify things a little bit. Using two highly contrasting yarns of any weight and appropriately sized needles of any type you prefer, cast on in the way that is the most comfortable for you, casting on with both ends held together. Be careful that the two loops resulting from each cast-on stitch maintain an alternating color scheme—Color B, then Color A, etc. Cast on fifteen pairs, or thirty total stitches. If there is a slipknot involved in your cast-on, you may either leave it on as one of the pairs or remove it and cast on one extra pair.

When working the edges, it is important to include a full twist in the first pair you work. After this pair, no further twisting is necessary except where color changes occur (and at those points, twisting occurs naturally). The edge twist locks the two sides of the fabric together at the edge.

In the chart below, there are two types of pairs you will be creating. The first is used for the Color A (white) stitches or pixels, as

I call them, on the facing-side (odd-numbered) rows and the Color B (blue) pixels on the opposite-side (even-numbered) rows. The second is used for the Color B pixels on the facing-side rows and the Color A pixels on the opposite-side rows. As you work, you'll notice that whenever you use Color A on the facing side, you'll use Color B on the opposite side, and vice versa. On the opposite-side (even-numbered) rows, you are working with the opposite side facing you and the colors (and orientation) will reverse. In this exercise, however, because the background pixels (Color A in the chart) are always the same as those in the row below for at least the first two pairs, it is easy to remember which color to start with (and therefore whether you are on a facing-side or opposite-side row). Also, the pattern is symmetrical in both directions, which means that you don't have to worry about following the chart backward in every other row.

The first type of pair you will create will be used for the entire first row of the chart:

* K1 Color A wyib. P1 Color B wyif. Rep from * across row.

When you reach the end of the chart and turn the work, you will use the second type of pair for the entire second row:

* K1Color B wyib. P1 Color A wyif. Rep from * across row.

You'll notice that the only thing that is changing is the color orientation—the knitting structure of the pair does not change from facing to opposite side, or when color changes occur.

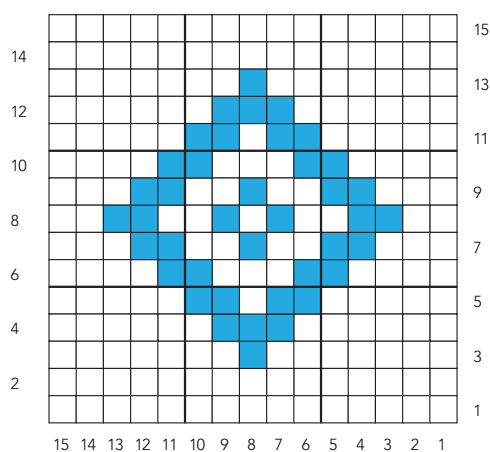

Double-knitting exercise chart



Falling Blocks, in three-colored two-pattern double-knitting



Whorl'd Tree in four-color two-pattern double-knitting

At this point, you can follow along with the chart, working the next row (and all facing-side rows) with the first pair type for Color A pixels on the chart and the second pair type for Color B pixels. Then, work the row after that (and all opposite-side rows) with the second pair type for Color A pixels

on the chart and the first type for Color B pixels. Don't forget to incorporate a twist into the first pair on each row!

When you're done, binding off the work is nearly as easy as any other bind-off. Simply start working the next row (it will be an opposite-side row), and whenever you have

two loops on the right needle, pull the first over the second and off the needle. Make sure to keep moving the yarn from front to back as you go.

Two-pattern double-knitting

Letters in particular have been troublesome for double-knitters—because the opposite side shows the mirror image of the facing side, many letters of the alphabet are unreadable on one side of standard double-knitting. I stumbled across a way of working the two faces in different patterns after making a mistake and working both the knit and the purl stitch of a particular pair in the same color. I was surprised to find that this can be done, to some degree, in double-knit fabric. You can't make both sides the same color—you would end up with 1×1 ribbing—but you can make some pairs both Color A and some both Color B. If it is possible to make one pair not follow the rule of reversing colors, it is possible to use this technique to work two patterns, one on each side.

Multicolor double-knitting

Up until now, traditional double-knitting has been limited to two colors. Indeed, even stranded colorwork is usually limited to two colors per row or round, mostly because of the difficulty of managing three or more ends.

Multicolor double-knitting is actually done using the same pair structure as standard double-knitting. There are still only two faces, one knit and one purl per pair. However, if there are three ends, the unused color has to be hidden somewhere.

The structure of double-knitting comes into play here. Remember—there is a space inside each pair. The more pairs of the same color configuration in an area, the more likely you'll be able to actually separate the two sides of the fabric. But even a single pair alone in an expanse of the opposite color has a space between its knit and its purl. That space can be used to hide things like unused strands of third colors until they are wanted.

Double-knit cables

This technique came to me while pondering reversible cables. Some time ago I made a Möbius scarf with a pair of thick reversible cables running all the way around it. These cables were of the 1×1 ribbing type, where the cable twist locks the 1×1 rib in a



Pacific

60% Acrylic
40% Superwash
Merino Wool

Over 75 Designer Colors

Soft as ever
After Washing and Drying

Download the Linda Voss Plummer
Pattern free at cascadeyarns.com



compressed state and makes the cable look the same on both sides.

As I mentioned earlier, double-knitting is essentially 1×1 ribbing done in two colors—the movement of the ends should remind you of that every time you double-knit. So the jump from reversible cables to double-knit cables was not difficult.

Most people assume that cables in double-knitting are not possible or practical because the two layers are worked together. Separating the layers, doing a cable twist on both sides, then returning the pairs to a single needle again every time you want to make a cable is indeed impractical—which

isn't to say it's not possible. I just think it deviates too far from double-knitting to be called such.

Instead, in much the same way you do reversible cables in 1×1 ribbing, you treat the whole fabric as a single layer. Therefore, a 3×3 cable is actually six pairs wide, or twelve stitches. The resulting cables are thicker than normal because, at the location of the twist itself, there are four layers of fabric.

These are just a few of the double-knitting variations explored in Extreme Double-Knitting. With detailed explanations, over 170 illustrations, and fourteen patterns, Extreme

Double-Knitting guides knitters from basic to very advanced techniques—many of which are being published for the first time.

For more info on Extreme Double-Knitting, please visit www.cooperativepress.com or www.double-knitting.com. For videos of the techniques used in the exercise, please visit www.youtube.com/user/fallingbox.

Alasdair Post-Quinn's broad range of interests, including origami and gaming, influence his knitting design. He lives in the Boston area with his wife and cat.



Silk City in standard flat double-knitting

origin'
BERGERE DE FRANCE

Pattern 194.82
Quality
MERINOS
Brasier
no 242.87

Pattern taken
from our
magazine
ORIGIN'

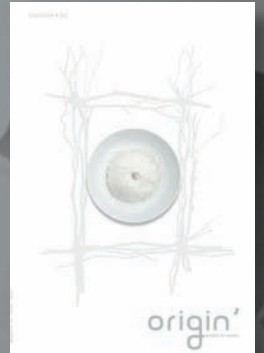

visit www.bergeredefrance.com
for your nearest retailer

BERGERE
de France

Tél. 1 800 361-0090 - Fax (1) 450-655-1272 - info@bergeredefrance.us - www.bergeredefrance.com
Mobile 07968 536333 - Tel/Fax 01606 883149 - email: gordonjleslie@bergeredefrance.co.uk



Maura Kirk



Maura Kirk

Kate & Courtney on Courtney & Kate

KATE GAGNON OSBORN
& COURTNEY KELLEY

*Kate Gagnon Osborn and Courtney Kelley are the businesswomen behind Kelbourne Woolens, the sole distributor of The Fibre Company yarns. They are handknitting designers and authors of the book *Vintage Modern Knits* (Interweave, 2010). They live and work in Philadelphia, Pennsylvania, where they sat down to have a conversation about knitting, inspiration, and yarn.*

BEGINNINGS

KGO: How did your knitting life get started, Courtney?

CK: I learned how to knit when I was a kid, but just garter stitch, from my grandma. She taught me when I was maybe in third grade. How old are you then? Nine? I had yellow plastic needles and burgundy acrylic yarn.

KGO: Every time you tell that story, you remember those two colors.



Courtney Kelley

CK: They made a very lasting impression. I carried them around with me forever, including when I went to college. I was at the School of the Art Institute of Chicago, where I was studying painting, and I wanted to do something more practical. I wanted something to do, I guess. I took a weaving class and I really liked it. My weaving instructor, Lindsay Obermeyer, had a store called Weaving Workshop in Chicago—it's now called Knitting Workshop—and she had knitters who worked there, but she needed a weaving person. I got a job working there on the weekends, but one of the prerequisites was that I had to learn to knit. So I got out the burgundy acrylic yarn and yellow plastic needles, went to the thrift store for a copy of the *Reader's Digest Complete Guide to Needlework*, and I set to it. Then I graduated with an art degree and went to Philadelphia, where I learned that the only employ-

able skill I had was knowing how to work at a yarn store.

KGO: Yay, art school!

<both laugh>

CK: So I worked in a yarn store for the next ten years and became the manager. We carried the Fibre Company yarns, and I developed a relationship with the owners.

KGO: You had your own line of patterns, right?

CK: Yeah. This was pre-Ravelry, the early days of PDF downloads. I had a very rudimentary, pretty ugly website, and people could download my patterns.

KGO: This was the nineties? Or later?

CK: It was this century, but early.

KGO: Well, my maternal grandmother taught me to knit, then my paternal grandmother taught me to sew. And I also went to art school. I went to Skidmore College in upstate New York for a bachelor's degree in studio art with a concentration in textiles. After a few years of wandering around the country, I also moved to Philadelphia to get a master's degree in textile design in industrial design-based applications. I got a weekend job at the same yarn shop where you were working because even with master's credits, there's very little you can do with an art degree.

<both laugh>

KGO: The shop we worked for had a project of the month. Every month, we came out with an original pattern to support one of the yarns in the shop. The Selbu Modern, which is now an iconic Kelbourne pattern, was originally a project of the month. We had pretty loose contractual agreements! At that time, due to my school schedule and your life schedule, we left the yarn shop and started our own company, Kelbourne Woolens, to distribute The Fibre Company's yarns.

CK: And here we are! The Fibre Company is owned by Iain Stanley and Daphne Marinopoulos. We do the advertising, marketing, and pattern support, as well as yarn and color development. Daphne does the sample dyeing. We'll say, "We need yellowy greens, or golds, or coppery stuff," and then she messes around and sends us samples. That's how we all work together now, and it works really well.

MAGNETIC AESTHETICS

KGO: We have different design aesthetics, but we've worked together to create a cohesive look for The Fibre Company

and Kelbourne Woolens, as well as for our book. Tell us about what you like, Courtney.

CK: I like whimsical, retro-inspired stuff. I do not shy away from intarsia woodland creatures, much to your chagrin. I find the recent past more inspiring. I like going to thrift stores. I like finding wacky stuff. But if I were just knitting for myself—

KGO: Don't you really want to knit yourself a pullover in Organik, in Dead Sea? A black sweater?

CK: Now when I'm home, I wear jeans and a black hoodie and a gray T-shirt. When I knit stuff, it's mostly because I like to knit things. I used to do this thing where I'd find ridiculous dresses at flea markets, and I would knit cardigans to go with them. I have yarn right now for a crazy cat dress. It's a green cat print, photorealistic cats, not illustrations. The greens of the yarn and the dress match exactly. So all told, I like really utilitarian stuff—and really goofy stuff. I think of my knitting sometimes like it's costume design and approach it from that standpoint. What about the preppy things that you hold so dear?

KGO: It's interesting, because I didn't really have a New England identity when I lived in New England. In many respects, my love of preppy things is sort of ironic and tongue-in-cheek, though I don't know if people see it that way.

CK: <laughs> Why do you like striped things so much?

KGO: I like the way they look! And gray is my favorite color. If I could only knit and wear gray all day I'd be really happy. I think I like classic, traditional preppy style with a twist, so it doesn't take itself too seriously. For example, corduroy pants embroidered with lobsters are the best thing ever, but I don't actually take them seriously.

CK: You should knit navy blue pants with intarsia lobsters.

KGO: On principle, I don't really knit pants.

<both laugh>

CK: It's hard to talk about inspiration, because I feel like I just like what I like. It does all relate to who you are and where you're from. But I feel like it comes from so many places, from what you see, how you feel, the season, what's happening around you. And it's always changing.

KGO: But I think even with us—the punk-rock-cat lover and me, the crazy preppy—we do find common ground.

CK: Yeah, there's a lot of overlap.

KGO: We both appreciate vintage techniques and traditional bases with modern tweaks. The Fibre Company yarns are really emblematic of that—unexpected fiber contents and blends but an overall classic style. And we really wanted *Vintage Modern Knits* to be unique, to have that same feel.

CK: Vintage inspirations and traditional and historical influences as well.

KGO: Do you remember how we got to the themes?

CK: I remember the three themes happening fast. Vintage Feminine, which ended up being the middle chapter, was very much directed by you. You pulled the colors and imagery. The Rustic Weekend theme was more what I wanted. And the imagery for the last theme, Winter Harbor—both of us were like, "Oh, well, we love that."

KGO: Right. Hot toddies! Everything felt very cohesive. The process has helped us with our general focus, with what we do in our own collections, and with our company. In some respects, it was difficult because the book came at the beginning of Kelbourne Woolens—we had worked together but not in that way. We learned a lot in a short period about our working relationship.

CK: Now each of us knows what the other can do.

Below: A design board for a Kelbourne Woolens pattern collection.



designer profile

KGO: And can't do! We had to be constantly communicating with each other: "What are you doing, how are you doing, where are you?"

CK: "What are you doing next?"

KGO: "What's going on?" It was good for that.

A DAY IN THE LIFE

KGO: So how would you describe our typical day?

CK: We both come to work well rested, having done lots of really soothing knitting and eaten good, locally grown organic dinners and breakfasts. Then we drink herbal tea and ask each other, "What do we feel like doing today?"

KGO: <laughs> None of that's true. Although we do both have pretty great gardens.

CK: Well, we do get to work. There are usually bagels involved. We go through the emails together: "Did you do this, did you do that, did you take care of these people, I need to call this woman . . ." I usually get to work early, and you usually stay late—I take Clyde to school early but leave earlier to pick him up. You walk the dogs in the morning and stay later. So we do a little catch up—"What happened after I left, what happened before I got here?"

We do everything! We're the ones who answer the phone when you call to place an order or ask a question. We email you back. I love it when people ask us if we can "have the guys in the warehouse check something." It's just me and you!

KGO: We do all the packing, the shipping, the billing, the invoicing, and the accounting.

CK: You do all the graphic and Web design and handle the ads, and I do the bookkeeping and pay the bills.

KGO: Every day, we handle the business stuff. During the course of the year, we also design pattern collections to support the yarns, and we contribute to magazines and books. But none of the knitting or designing happens during the day. All of that happens on our own time at night.

CK: It would be amazing if we just came into work and knitted all day.

KGO: Except the company would go under. But when we're creating a collection, we have design planning meetings together, which usually involve a storyboard and a color story and a theme.

CK: Those are fun.

KGO: We also do the yarn and color development. And now we've developed a new yarn, Acadia.

CK: It was a two-year process. All of our yarns are custom spun in custom blends, so yarn development takes a long time. It's that way because Daphne and Iain had their own mill for years, which is how The Fibre Company started—so they could put all kinds of fibers in the yarns.

KGO: The process is still long. We have an idea of what we want the yarn to be like—for Acadia, it's a blend of 60% merino, 20% alpaca, and 20% silk. We knew we wanted it to be a two-ply, and we knew about the weight we wanted, but the mill still had to do a lot of sampling for us.

CK: It started as a bulky! Remember that?

KGO: Oh, yeah! Wow. And the fiber percentages changed. Acadia is unique—it has silk noil. The slubs of raw silk create a tweed effect. We had to play with the percentages. The 20% silk is a combination of silk and silk noil.

CK: Originally, it was 20% silk noil, and it was too—

KGO: Noily.

CK: And the alpaca in the yarn is now much darker than we first thought it should be. Originally, it was a pretty brownish gray, but when we mixed in the silk and the wool, the alpaca got lost and just looked dirty. So we ended up using an alpaca that's really dark brown, almost black.

KGO: So the process requires a lot of back and forth. Once we were set on the exact yarn and gauge and blend—

CK: And twist. The twist went through quite a few iterations. It wasn't twisted enough at first.

KGO: The skeins were floppy.

CK: After all that, we do color development. The colors initially start with lab dips.

KGO: The lab dip is a little 10-yard winding dyed at the mill instead of having the hand-dyers work with huge pots. With the same percentage of dye based on the weight of the yarn, they dye tiny pots just to see. It gives us an idea of what the yarn's going to look like. Acadia is the first completely new yarn; it didn't exist before we started Kelbourne Woolens. We're really excited about the yarn and doing more development for the future. In fact, we just had a little powwow about the next yarn.

CK: It's either going to be really bulky—or really skinny! <laughs> I often think about what I would be doing if I weren't doing this. And I have no idea. What would you do?

KGO: I don't know. I'm glad I don't have to think about it. Because this is pretty neat. ■



Clockwise from center: the Selbu Modern, the Avery Cowl (with cat dress); Acadia yarn.





yarn.com

Save up to 25% off
with WEBS® yarn and
book discount.



#403 Jambalaya Shawl



#281 Point and Line Cardigan



#386 Mystic Pullover



#355 Manta
Top-Down Tee



WEBS carries a wide selection of yarns and pattern books from Rowan, and all of your favorite brands. You'll also find all the tools and accessories knitters and crocheters need to make your project a success.

Saving couldn't be easier with WEBS' discounts!

Spend \$60 or more on discountable yarn and books and deduct 20% from your purchase. Spend \$120 or more on discountable yarns and books and deduct 25%.



Join us on Facebook
facebook.com/websyarn

Follow us on Twitter
twitter.com/kathyelkins
twitter.com/websyarnstore



America's Yarn Store®

yarn.com | 1.800.367.9327

VISIT OUR STORE: 75 SERVICE CENTER ROAD, NORTHAMPTON, MA



The Elements of Knitting

Chunky yarns render knitted
stitches into sculptural elements.

2.25 stitches per inch



Cables and purl background areas grow gradually to give the **CARDIFF COAT** seamless, invisible shape. **JENNIFER WOOD** mixes traditional and reversible cables to create a coat with strong lines and a collar that can be worn up or down. **PAGE 34.** YARN Blue Sky Alpacas Bulky



2.25 stitches per inch



Shetland-style lace goes iconic when worked in a bold, chunky gauge: Rendered in light-as-air unspun roving, the fern lace pattern of the **PEMBROKE WRAP** has puffy, textural loft. **ANDREA RANGEL** uses traditional triangular shawl construction for a familiar piece with modern edge. **PAGE 37. YARN** Imperial Yarn Bulky 2 Strand Pencil Roving



The Elements
of Knitting

3.4 stitches per inch

A chunky (but not too chunky) yarn gives the cables and shaping lines of the quick-knitting **BRYN MAWR SKIRT** three-dimensional texture but keeps the fabric light and flattering. **NANCY EISEMAN** uses seed stitch as a background element for lofty pop. **PAGE 40. YARN** Cascade Yarns 128



The Elements
of Knitting

Patterned all over with scattered lace snowflakes, **JILL DRAPER'S SNOWFALL SWEATER** makes large-scale lace into a modern study in positive and negative space. A yarn with an unusual air-puffed core encased in wool helps a super bulky sweater feel light and drapey. **PAGE 42.** **YARN** Schulana Cortina Nuvole, distributed by Skacel

2.6 stitches per inch

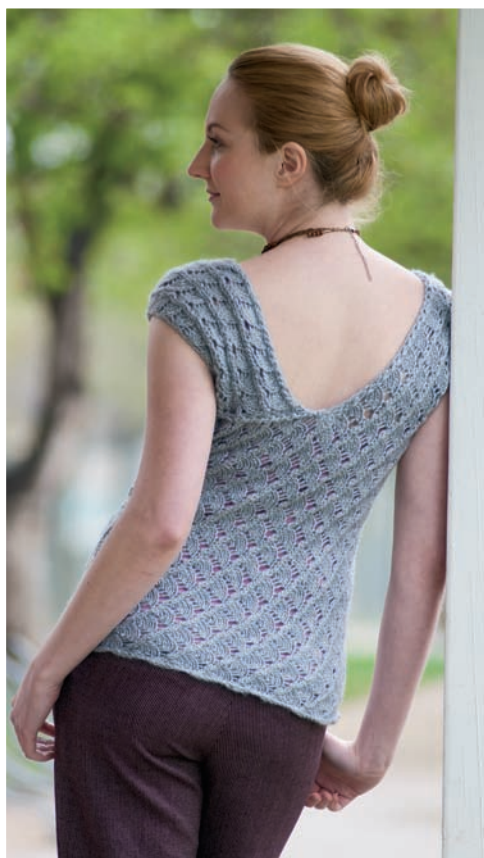

4 stitches per inch

RACHEL ERIN works a continuously spiraling lace pattern up the body before dividing for the neck and arms, creating a biased fabric that skims and flows in the **STROBILUS PULLOVER**. A puffy merino-and-cashmere-blend yarn throws the scalloped lace pattern into high relief. **PAGE 46.**
YARN Classic Elite Yarns Ariosa



*The Elements
of Knitting*

The **SHADOW TUQUE'S** simple cables become elemental, organic waves when worked with a bulky yarn on a stockinette-stitch background. **LEE JUVAN. PAGE 48. YARN** Classic Elite Yarns Toboggan



3 stitches per inch



Super-chunky moss stitch across a simple raglan cardigan shows off the fundamental appeal of knitted stitches. **CAROL FELLER** punctuates the **CARDIGAN BAY JACKET'S** pebbled surface with eyelet shaping lines and neat, trim edges. **PAGE 50. YARN** Rowan Big Wool, distributed by Westminster Fibers

2.25 stitches per inch



CARDIFF COAT

Jennifer Wood

Finished Size 29 (32 $\frac{3}{4}$, 35 $\frac{1}{4}$, 49 $\frac{3}{4}$, 55, 59 $\frac{1}{2}$)" bust circumference, buttoned. Cardigan shown measures 32 $\frac{3}{4}$ ".

Yarn Blue Sky Alpaca Bulky (50% alpaca, 50% wool; 45 yd [41 m]/3 $\frac{1}{2}$ oz [100 g]): #1002 silver mink, 18 (20, 21, 28, 31, 33) skeins.

Needles Body and sleeves—size 15 (10 mm): 40" circular (cir) and set of double-pointed (dnp). I-cord edging—size 17 (12.75 mm): Two dnp. Adjust needle size if necessary to obtain the correct gauge.

Notions Markers (m); stitch holders; cable needle (cn); waste yarn for provisional CO; tapestry needle; five 1 $\frac{1}{2}$ " buttons.

Gauge 9 sts and 12 rows = 4" in St st on smaller needle; Yoke C cable plus 5 rev St sts = 4 $\frac{1}{4}$ " wide.

Stitch Guide

Seed Stitch: (over an odd number of sts)

Row 1: K1, *p1, k1; rep from * to end.

Rep Row 1 for patt.

COAT

Collar: With smaller cir needle, CO 68 (68, 68, 104, 104, 104) sts. Do not join.

Row 1: (RS of collar; WS of coat) *Work 5 sts in seed st (see Stitch Guide), [k1f&b] 4 times; rep from * to last 5 sts, work 5 sts in seed st—96 (96, 96, 148, 148, 148) sts. Work Rows 1–18 of Collar chart—42 (42, 42, 62, 62, 62) sts rem. **Yoke: Inc row:** (RS) Work 3 sts in seed st, *p1, [M1P] 0 (1, 1, 0, 1, 1) time, pm, work Row 1 of Yoke A chart, pm, [M1P] 0 (0, 1, 0, 0, 1) time, p1, [M1P] 0 (1, 1, 0, 1, 1) time, pm, work Row 1 of Yoke B chart, pm, [M1P] 0 (0, 1, 0, 0, 1) time; rep from * to last 9 sts, p1, [M1P] 0 (1, 1, 0, 1, 1) time, pm, work Row 1 of Yoke A chart, pm, [M1P] 0 (0, 1, 0, 0, 1) time, p1, [M1P] 0 (1, 0, 0, 1, 0) time, work 3 sts in seed st—42 (50, 56, 62, 74, 84) sts. Work 5 rows even in patt, working new sts in rev St st, ending with chart row 6.

Sizes 29 (49 $\frac{3}{4}$)" only:

Inc row: (RS) Work 3 sts in seed st, *p1, M1P, sl m, work chart to m; rep from * to last 4 sts, p1, M1P, work 3 sts in seed st—50 (74) sts.

Sizes 32 $\frac{3}{4}$ (35 $\frac{1}{4}$)" only:

Inc row: (RS) Work 3 sts in seed st, p2, M1P, sl m, [work chart to m, p1, M1P, p1 (2), M1P, sl m] 2 times, [work chart to m, M1P, p2 (3)] 2 times, [work chart to m, p1, M1P, p1 (2), M1P, sl m] 2 times, work chart to m, p1, M1P, p1, work 3 sts in seed st—62 (68) sts.

Sizes 55 (59 $\frac{1}{2}$)" only:

Inc row: (RS) Work 3 sts in seed st, p2, M1P, sl m, work chart to m, p2 (3), M1P, sl m, [work chart to m, p1, M1P, p1 (2), M1P, sl m] 2 times, [work chart to m, p2 (3), M1P, sl m] 4 times, [work chart to m, p1, M1P, p1 (2), M1P] 2 times, work chart to m, sl m, M1P, p2 (3), work chart to m, sl m, M1P, p2, work 3 sts in seed st—90 (100) sts.

Sizes 29 (32 $\frac{3}{4}$, 35 $\frac{1}{4}$)" only:

Work 5 rows even in patt, ending with chart row 6. **Inc row:** (RS) Work 3 sts in seed st, p2 (3, 3), M1P, sl m, [work chart to m, p1, M1P, p1 (3, 4), M1P, sl m] 2 times, [work chart to m, p2 (3, 4), M1P, sl m] 2 times, [work chart to m, p1, M1P, p1 (3, 4), M1P, sl m] 2 times, work chart to m, p1, M1P, p1 (2, 2), work 3 sts in seed st—62 (74, 80) sts. Work 2 rows even in patt,

ending with chart row 3. **Inc row:** (WS) Work 3 sts in seed st, k3 (4, 4), work chart to m, k4 (6, 7), sl m, RLPI (see Glossary), p4, LLPI (see Glossary), sl m, k4 (6, 7), work chart to m, k3 (4, 5), sl m, RLPI, p4, LLPI, sl m, k3 (4, 5), work chart to m, k4 (6, 7), sl m, RLPI, p4, LLPI, sl m, k4 (6, 7), work chart to m, k3 (4, 4), work 3 sts in seed st—68 (80, 86) sts. Work 1 row even, working new sts in St st. **Inc row:** (WS) Work 3 sts in seed st, k3 (4, 4), sl m, RLPI, p4, LLPI, sl m, k4 (6, 7), p6, k4 (6, 7), sl m, RLPI, p4, LLPI, sl m, k3 (4, 5), p6, k3 (4, 5), sl m, RLPI, p4, LLPI, sl m, k4 (6, 7), p6, k4 (6, 7), sl m, RLPI, p4, LLPI, sl m, k3 (4, 4), work 3 sts in seed st—76 (88, 94) sts. Work 2 rows even, working St st in place of charts. **Inc row:** (RS) Work 3 sts in seed st, p3 (4, 4), M1P, sl m, [k6, p4 (6, 7), M1P, sl m] 2 times, [k6, p3 (4, 5), M1P, sl m] 2 times, [k6, p4 (6, 7), M1P, sl m] 2 times, k6, p1, M1P, p2 (3, 3), work 3 sts in seed st—84 (96, 102) sts. Work 1 row even. **Inc row:** (RS) Work 3 sts in seed st, p4 (5, 5), [k6, p5 (7, 8), M1P, sl m] 2 times, [k6, p4 (5, 6)] 2 times, [k6, p5 (7, 8), M1P, sl m] 2 times, k6, p4 (5, 5), work 3 sts in seed st—88 (100, 106) sts. Work 1 row even. **Next row:** (RS) *Work to m, work Row 1 of Yoke C chart, sl m, work to m, work Row 1 of Yoke D chart, sl m; rep from * 2 more times, work to m, work Row 1 of Yoke C chart, work to end. Work

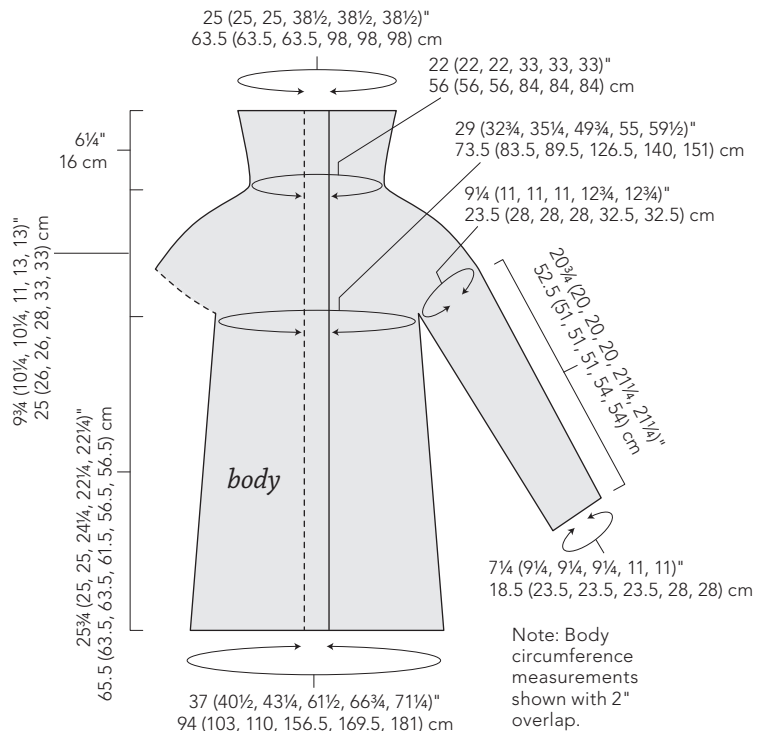

3 rows even, ending with chart row 4. **Inc row:** (RS) Work 3 sts in seed st, p4 (5, 5), [work chart to m, p1, M1P, p5 (7, 8), M1P, sl m] 2 times, [work chart to m, p4 (5, 6)] 2 times, [work chart to m, p1, M1P, p5 (7, 8), M1P, sl m] 2 times, work chart to m, p4 (5, 5), ssk, yo, k1—96 (108, 114) sts.

Sizes 32¾ (35¼)" only:

Work 1 row even. **Inc row:** (RS) Work 3 sts in seed st, p5, [work chart to m, p10 (11), M1P, sl m] 2 times, [work chart to m, p5 (6)] 2 times, [work chart to m, p10 (11), M1P, sl m] 2 times, work chart to m, p5, work 3 sts in seed st—112 (118) sts.

Sizes 49¾ (55, 59½)" only:

Work 5 rows even in patt, ending with chart row 6. **Inc row:** (RS) Work 3 sts in seed st, p2 (3, 3), M1P, sl m, work chart to m, p2 (3, 4), M1P, sl m, [work chart to m, p1, M1P, p1 (3, 4), M1P, sl m] 2 times, [work chart to m, p2 (3, 4), M1P, sl m] 4 times, [work chart to m, p1, M1P, p1 (3, 4), M1P, sl m] 2 times, work chart to m, p2 (3, 4), M1P, sl m, work chart to m, p1 (2, 2), M1P, p1, work 3 sts in seed st—90 (106, 116) sts. Work 2 rows even in patt,

ending with chart row 3. **Inc row:** (WS) Work 3 sts in seed st, k3 (4, 4), work chart to m, k3 (4, 5), sl m, RLPI, p4, LLPI, sl m, k4 (6, 7), work chart to m, k4 (6, 7), [sl m, RLPI, p4, LLPI, sl m, k3 (4, 5), work chart to m, k3 (4, 5)] 2 times, sl m, RLPI, p4, LLPI, sl m, k4 (6, 7), work chart to m, k4 (6, 7), sl m, RLPI, p4, LLPI, sl m, k3 (4, 5), work chart to m, k3 (4, 4), work 3 sts in seed st—100 (116, 126) sts. Work 1 row even, working new sts in St st. **Inc row:**

(WS) Work 3 sts in seed st, k3 (4, 4), sl m, RLPI, p4, LLPI, sl m, k3 (4, 5), p6, k4 (6, 7), sl m, RLPI, p4, LLPI, sl m, k4 (6, 7), [p6, k3 (4, 5), sl m, RLPI, p4, LLPI, sl m, k3 (4, 5)] 2 times, p6, k4 (6, 7), sl m, RLPI, p4, LLPI, sl m, k4 (6, 7), p6, k3 (4, 5), sl m, RLPI, p4, LLPI, sl m, k3 (4, 4), work 3 sts in seed st—112 (128, 138) sts. Work 2 rows even, working in St st in place of charts. **Inc row:** (RS) Work 3 sts in seed st, p2 (3, 3), M1P, p1, k6, p3 (4, 5), M1P, sl m, [k6, p4 (6, 7), M1P, sl m] 2 times, [k6, p3 (4, 5), M1P, sl m] 4 times, [k6, p4 (6, 7), M1P, sl m] 2 times, k6, p3 (4, 5), M1P, sl m, k6, p1, M1P, p2 (3, 3), work 3

sts in seed st—124 (140, 150) sts. Work 1 row even. **Inc row:** (RS) Work 3 sts in seed st, p4 (5, 5), k6, p4 (5, 6), [k6, p5 (7, 8), M1P, sl m] 2 times, [k6, p4 (5, 6)] 4 times, [k6, p5 (7, 8), M1P, sl m] 2 times, k6, p4 (5, 6), k6, p4 (5, 5), work 3 sts in seed st—128 (144, 154) sts. Work 1 row even. **Next row:** (RS) *Work to m, work Row 1 of Yoke C chart, sl m, work to m, work Row 1 of Yoke D chart, sl m; rep from * 4 more times, work to m, work Row 1 of Yoke C chart, work to end. Work 3 rows even, ending with chart row 4. **Inc row:** (RS) Work 3 sts in seed st, p4 (5, 5), work chart to m, p4 (5, 6), [work chart to m, p1, M1P, p5 (7, 8), M1P, sl m] 2 times, [work chart to m, p4 (5, 6)] 4 times, [work chart to m, p1, M1P, p5 (7, 8), M1P, sl m] 2 times, work chart to m, p4 (5, 6), work chart to m, p4 (5, 5), ssk, yo, k1—136 (152, 162) sts. Work 1 row even. **Inc row:** (RS) Work 3 sts in seed st, p4 (5, 5), work chart to m, p4 (5, 6), [work chart to m, p8 (10, 11), M1P, sl m] 2 times, [work chart to m, p4 (5, 6)] 4 times, [work chart to m, p8 (10, 11), M1P, sl m] 2 times, work chart to m,

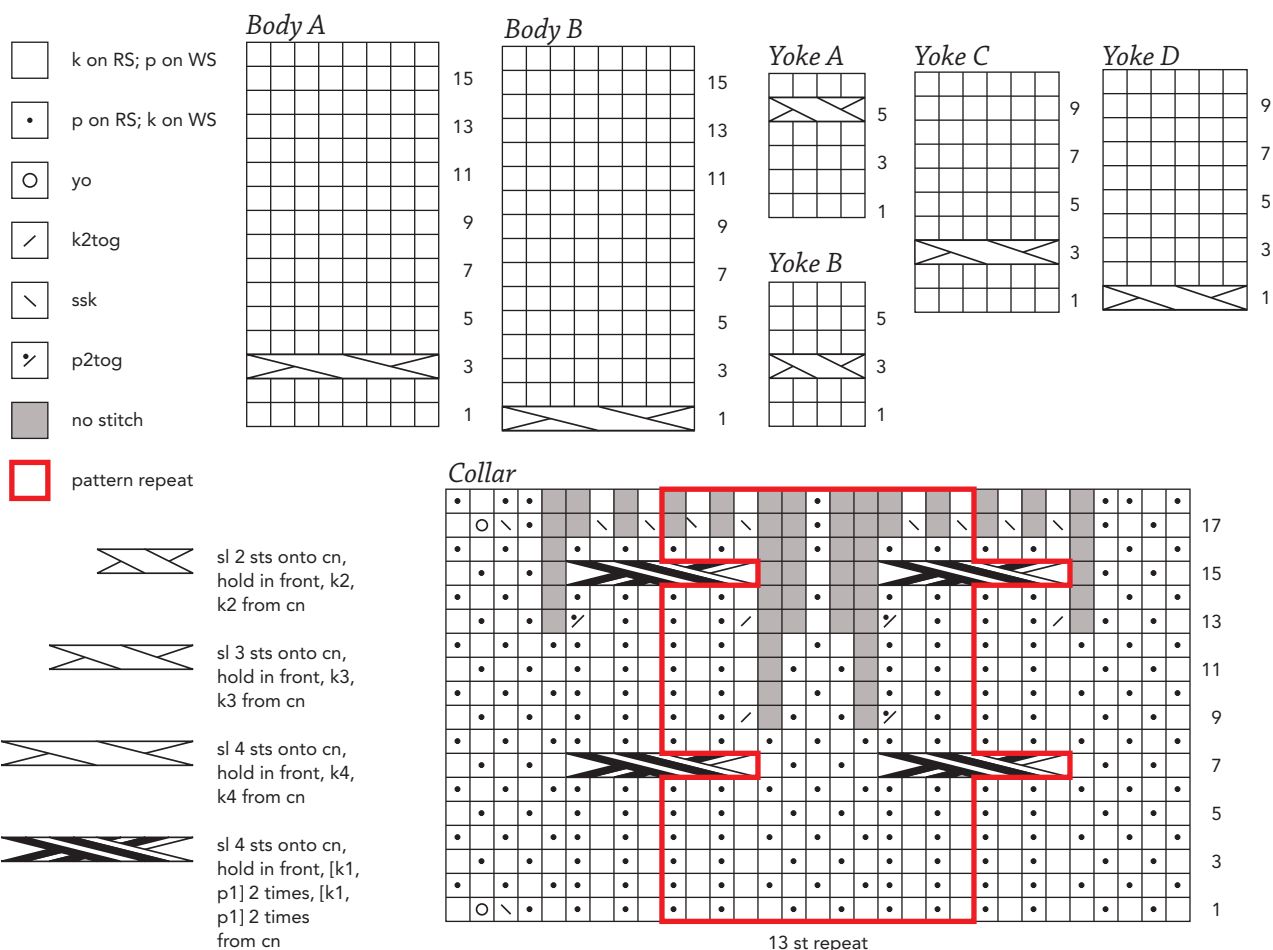



p4 (5, 6), work chart to m, p4 (5, 5), work 3 sts in seed st—140 (156, 166) sts. Work 1 row even. **Inc row:** (RS) Work 3 sts in seed st, p3 (4, 4), M1P, p1, work chart to m, p4 (5, 6), M1P, sl m, [work chart to m, p1, M1P, p8 (10, 11), M1P, sl m] 2 times, [work chart to m, p4 (5, 6), M1P, sl m] 4 times, [work chart to m, p1, M1P, p8 (10, 11), M1P, sl m] 2 times, work chart to m, p4 (5, 6), M1P, work chart to m, p1, M1P, p3 (4, 4), work 3 sts in seed st—156 (172, 182) sts.

Sizes 55 (59½)" only:

Work 5 rows even, ending with chart row 4. **Inc row:** Work 3 sts in seed st, p6, work chart to m, p6 (7), [work chart to m, p13 (14), M1P, sl m] 2 times, [work chart to m, p6 (7)] 4 times, [work chart to m, p13 (14), M1P, sl m] 2 times, work chart to m, p6 (7), work chart to m, p6, work 3 sts in seed st—176 (186) sts.

All sizes:

Divide sleeves and body: (WS) Work

17 (19, 20, 30, 33, 35) sts, place next 14 (18, 18, 18, 22, 22) sts on holder for sleeve, CO 6 sts for underarm using the backward-loop method, work 34 (38, 42, 60, 66, 72) sts for back, place next 14 (18, 18, 18, 22, 22) sts on holder for sleeve, CO 6 sts for underarm, work to end—80 (88, 94, 132, 144, 154) body sts. Work 2 (0, 0, 8, 2, 2) rows even in patt, ending with a WS row, working underarm CO sts according to Yoke D (Yoke D, Yoke D, Yoke C, Yoke C, Yoke C) chart, beg with Row 7 (9, 9, 1, 7, 7) of chart. **Note:** For sizes 32¾" and 35¾", work underarm CO sts according to chart row 9 on next row. **Inc row:** (RS; Row 9 of charts) Work 3 sts in seed st, p4 (5, 5, 5, 6, 6), M1P, sl m, work chart to m, [p4 (5, 6, 5, 6, 7), M1P, sl m, work chart to m] 6 (6, 6, 10, 10, 10) times, p1, M1P, p3 (4, 4, 4, 5, 5), work 3 sts in seed st—88 (96, 102, 144, 156, 166) sts. Work 25 (25, 25, 15, 15, 15) rows even, ending with chart row 4. **Next row:** (RS;

buttonhole row) Work in patt to last 3 sts, ssk, yo, k1. Work 6 rows even, ending with chart row 1. **Inc row:** (WS) Work 3 sts in seed st, k5 (6, 6, 6, 7, 7), work chart to m, [k5 (6, 7, 6, 7, 8), sl m, RLPI, p6, LLPI, sl m, k5 (6, 7, 6, 7, 8), work chart to m] 3 (3, 3, 5, 5, 5) times, k5 (6, 6, 6, 7, 7), work 3 sts in seed st—94 (102, 108, 154, 166, 176) sts. Work 1 row even, working new sts in St st. **Inc row:** (WS) Work 3 sts in seed st, k5 (6, 6, 6, 7, 7), sl m, RLPI, p6, LLPI, sl m, [k5 (6, 7, 6, 7, 8), p8, k5 (6, 7, 6, 7, 8), sl m, RLPI, p6, LLPI, sl m] 3 (3, 3, 5, 5, 5) times, k5 (6, 6, 6, 7, 7), work 3 sts in seed st—102 (110, 116, 166, 178, 188) sts. Work 12 rows even, working St st in place of charts. **Next row:** (RS) *Work to m, work Row 1 of Body A chart, sl m, work to m, work Row 1 of Body B chart, sl m; rep from * 2 (2, 2, 4, 4, 4) more times, work to m, work Row 1 of Body A chart, work to end. Work 3 rows even in patt, ending with chart row 4. **Inc row:** (RS) Work 3 sts in seed st, p5 (6, 6, 6, 7, 7), M1P, sl m, work chart to m, [p5 (6, 7, 6, 7, 8), M1P, sl m, work chart to m] 6 (6, 6, 10, 10, 10) times, p1, M1P, p4 (5, 5, 5, 6, 6), work 3 sts in seed st—110 (118, 124, 178, 190, 200) sts. Work 3 rows even, ending with chart row 8. **Next row:** (RS; buttonhole row) Work in patt to last 3 sts, ssk, yo, k1. Work 17 rows even, ending with chart row 10. Place sts on holder.

SLEEVES

With smaller dpn, RS facing, and beg at center of underarm, pick up and knit 4 sts along CO sts, work 14 (18, 18, 22, 22) held sleeve sts in patt, pick up and knit 4 sts along CO sts to center of underarm, pm and join in the rnd—22 (26, 26, 30, 30) sts total. Work 28 (26, 26, 30, 30) rnds even in patt, working picked-up sts in rev St st, and ending last rnd 3 sts before end of rnd. **Dec rnd:** P2tog, p1, sl m, p1, ssp, work in patt to end of rnd—2 sts dec'd. Work 9 rnds even, ending last rnd 3 sts before end of rnd. Rep Dec rnd—18 (22, 22, 26, 26) sts rem. Work 21 rnds even. Knit 1 rnd. BO all sts kwise.

FINISHING

I-cord edging: With RS facing and beg at left front lower edge, leave first 31 (33, 34, 48, 51, 53) sts on holder, transfer next 79 (85, 90, 130, 139, 147) sts to smaller cir needle. With larger dpn and using a provisional method (see Glossary), CO 3 sts. *K2, sl 1 kwise, sl 1 pwise from cir needle, knit these 2 sts tog tbl, slide sts to other

end of dpn; rep from * to end of cir needle; work corner as foll: k3, slide sts to other end of dpn, k2, sl 1 kwise, pick up and knit 1 st at lower right front corner, knit these 2 sts tog tbl, slide sts to other end of dpn, k3—end of corner; work attached I-cord (see Glossary) along right front edge to top of collar, picking up 6 sts for every 11 rows; work corner as before; work attached I-cord along CO edge of collar to corner, picking up 1 st for each CO st; work corner as before; work attached I-cord along left front edge to lower edge, picking up 6 sts for every 11 rows; work corner as before; transfer 31 (33, 34, 48, 51, 53) held sts to smaller cir needle; *k2, sl 1 kwise, sl 1 pwise from cir needle, knit these 2 sts tog tbl, slide sts to other end of dpn; rep from * to end of cir needle. Carefully remove waste yarn from provisional CO and place 3 sts onto larger dpn. Join ends tog using Kitchener st (see Glossary). Sew buttons to left front opposite buttonholes. Weave in loose ends. Block as desired.

Jennifer Wood lives with her family in the beautiful foothills of eastern Tennessee, where she knits at every available opportunity. She is the creator and owner of Wood House Knits, whose website you'll find at www.woodhouseknits.com.



PEMBROKE WRAP

Andrea Rangel

Finished Size 46" wide at top edge and 25" high at point, after blocking.

Yarn Imperial Yarn Bulky 2 Strand Pencil Roving (100% wool; 200 yd [183 m]/4 oz [113 g]): #112 wheat heather, 2 balls.

Needles Size 13 (9 mm). Adjust needle size if necessary to obtain the correct gauge.

Notions Marker (m); blocking pins; size N/15 (9 mm) crochet hook; smooth waste yarn in contrasting color.

Gauge 9 sts and 10 rows = 4" in leaf lace patt, after blocking.

NOTES

- This shawl is worked from the top down.
- It may be helpful to mark center stitch.

SHAWL

Top border: Using the crochet chain provisional method (see Glossary), CO 3 sts. Knit 6 rows; do not turn after last row. Rotate work and pick up and knit 3 sts down selvedge (1 st between each garter ridge), then gently remove waste yarn from CO sts and place 3 live sts on left needle, k3—9 sts total. Turn. **Set-up row:** (WS) K3 (edge sts), p1, p1 (center st), p1, k3 (edge sts). Work Rows 1–28 of Set-up Leaf chart—65 sts; 32 sts each side of center st. Work Rows 1–12 of Leaf Lace chart, working each patt rep 3 times—89 sts; 44 sts each side of center st. Work Rows 1–19 of Arrowhead Scallop Edge chart, working each patt rep 5

times—121 sts; 60 sts each side of center st. **Inc row:** (WS) K3, yo, k4, yo, k1, yo, *k7, yo, k1, yo; rep from * to 4 sts before center st, k4, yo, k1 (center st), yo, k4, yo, k1, yo, *k7, yo, k1, yo; rep from * to last 7 sts, k4, yo, k3—153 sts. Knit 1 row. BO all sts kwise on WS.

FINISHING

Carefully weave in all ends. Block pieces to measurements.

Andrea Rangel loves the functional and artistic nature of fiber arts, especially matching the perfect natural fibers to each project and season. She loves to be (and knit!) outdoors. She teaches, designs, and knits in Seattle, Washington. See her designs at www.andreaknits.com.



- k on RS; p on WS
- k on WS
- y o
- / k2tog
- \ ssk
- ^ sl 2 as if to k2tog, k1, p2sso
- pattern repeat

Arrowhead Scallop Edge

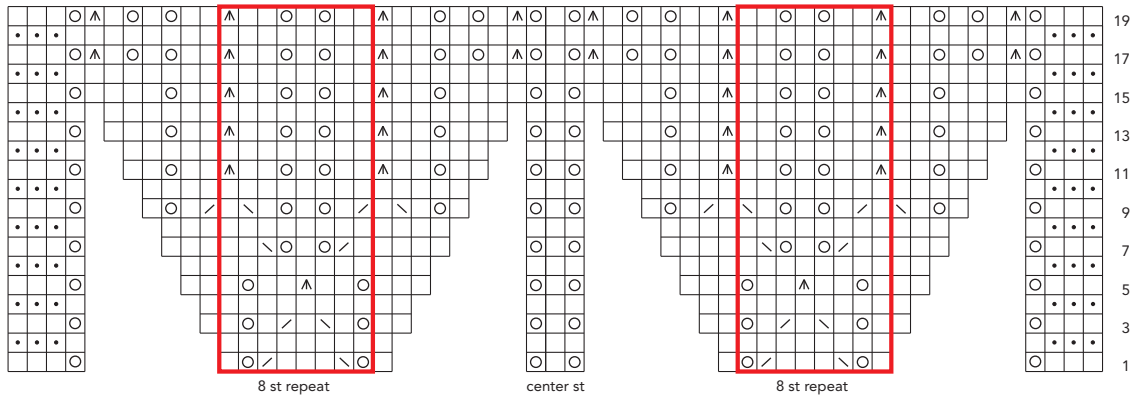

Leaf Lace

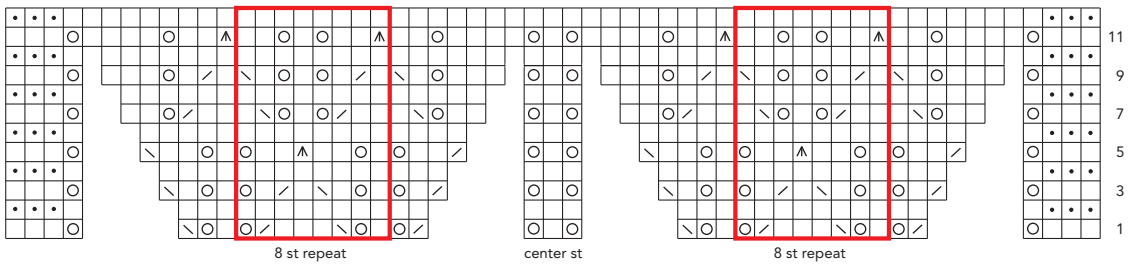

Set-up Leaf

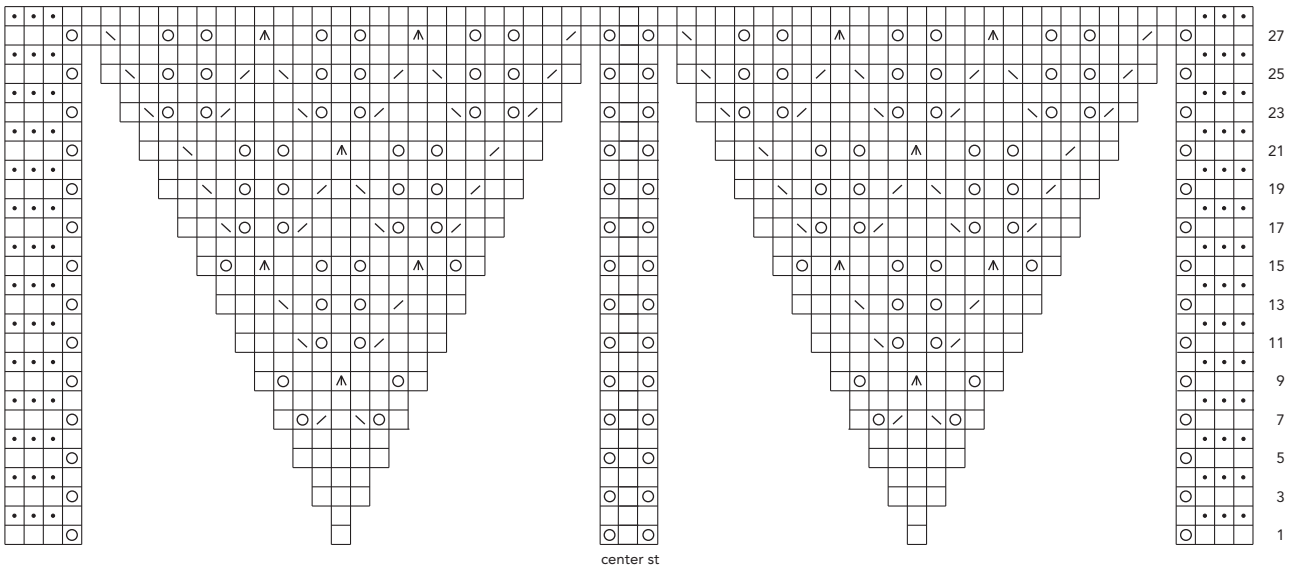

Spinning Colorful Dreams

Choose from
over 1,000
colors of
natural fiber
yarn for your
dream projects.

Quality Yarn from Quality People.



Brown Sheep Company, Inc.

MITCHELL, NEBRASKA

www.brownsheep.com



BRYN MAWR SKIRT

Nancy Eisman

Finished Size 22 (23½, 28, 31½, 34, 38½)" waist circumference and 35½ (38, 42¼, 47½, 49¾, 57)" hip circumference. Skirt shown in size 38".

Yarn Cascade Yarns 128 (100% Peruvian wool; 128 yd [117 m]/3½ oz [100 g]): #8401 light gray, 4 (4, 5, 6, 6, 7) skeins.

Needles Size 10 (6 mm): 32" circular (cir). Size 9 (5.5 mm): 24" and 32" cir. Adjust needle size if necessary to obtain the correct gauge.

Notions Cable needle (cn); markers (m); tapestry needle.

Gauge 13½ sts and 22 rnds = 4" in St st on larger needle. One 12-st (16-st) cable panel chart = 3½ (4)" wide.

NOTES

- This skirt is worked from the top down. To determine the most desirable length for you, try the skirt on as you go. Before trying the skirt on, thread a length of waste yarn through the stitches on the needle and remove them from the needle.

SKIRT

Waistband: With smaller 24" cir needle, CO 88 (94, 112, 126, 136, 154) sts. Place marker (pm) and join in the rnd. Work in



knit



purl

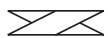

Sl 2 sts onto cn, hold in back, k2, k2 from cn

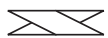

Sl 2 sts onto cn, hold in front, k2, k2 from cn

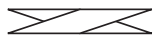

Sl 3 sts onto cn, hold in back, k3, k3 from cn

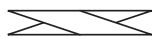

Sl 3 sts onto cn, hold in front, k3, k3 from cn

k1, p1 rib for 3". Change to larger needle.

Sizes 35½ (42¼, 49¾)" only: Knit 1 rnd.

Sizes 38 (47½)" only: [K46 (62), k1f&b] 2 times—96 (128) sts.

Size 57" only: [K25, k1f&b] 4 times, [k24, k1f&b] 2 times—160 sts.

All sizes: *K5 (6, 8, 8, 9, 12), pm, k12 (12, 12, 16, 16, 16), pm, k5 (6, 8, 8, 9, 12); rep from * 3 more times. *Knit to m, work Right Cable Panel chart over 12 (12, 12, 16, 16, 16) sts, knit to m, work Left Cable Panel chart over 12 (12, 12, 16, 16, 16) sts; rep from * once more, knit to end. Work through chart Rnd 6. **Inc rnd:** *Knit to 1 st before m, M1R, k1, work Right Cable Panel chart over 12 (12, 12, 16, 16, 16) sts, k1, M1L, knit to 1 st before m, M1R, k1, work Left Cable Panel chart over 12 (12, 12, 16, 16, 16) sts, k1, M1L; rep from * once more, knit to end—8 sts inc'd. Rep Inc rnd every 8th rnd 3 more times, then every 12 (12, 15, 15, 17, 17)th rnd 2 times—136 (144, 160, 176, 184, 208) sts. Work even until skirt measures about 16 (16, 17¼, 17¼, 18½, 18½)" from CO, ending with Row 6 (6, 6, 1, 1, 1) of Cable Panel charts. Change to smaller 32" needle.

Sizes 35½ (38, 42¼)" only: K1 (0, 0), [p1, k1] 8 (9, 10) times, p1, k2tog, *[p1, k1] 12 (13, 15) times, p1, k2tog, [p1, k1] 2 times, p1, k2tog; rep from * 2 more times, [p1, k1] 7 (6, 7) times, p0 (1, 1), [k2tog] 0 (1, 1) time—128 (136, 152) sts rem.

Sizes 47½ (49¾, 57)" only: P1 (0, 1), [k1, p1] 5 (6, 7) times, k1, p2tog, [k1, p1] 8 times, *k2tog, p1, [k1, p1] 11 (12, 15) times, k1, p2tog, [k1, p1] 8 times; rep from * 2 more times, k2tog, [p1, k1] 6 (6, 8) times, p0 (1, 0)—168 (176, 200) sts rem.

All sizes: Cont in seed st (knit the purl sts and purl the knit sts) until border measures 2¼". BO all sts.

Nancy Eisman learned to knit as child. After a thirty-five-year hiatus, she rediscovered knitting and became hopelessly addicted. She lives in Swarthmore, Pennsylvania, and works as a senior designer developing Jacquard-woven upholstery fabric for a major textile manufacturer.



Right Cable Panel, 35½ (38, 42¾)"

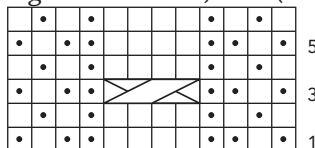

12 sts

Left Cable Panel, 35½ (38, 42¾)"

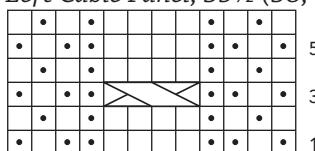

12 sts

Right Cable Panel, 47½ (49¾, 57)"

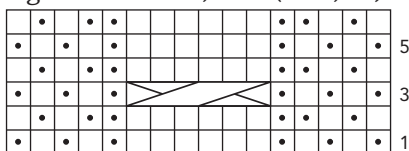

16 sts

Left Cable Panel, 47½ (49¾, 57)"

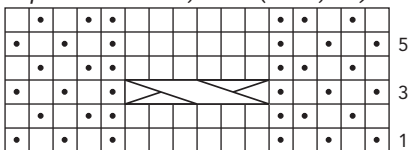

16 sts





YARN · FABRIC · FELT · BUTTONS · SEWING · THREAD · TOOLS · CROCHET · PATTERNS · KNITTING



NEEDLEPOINT · QUILTING · EMBROIDERY · CLASSES · BOOKS · CROSS-STITCH · GIFTS · NOTIONS



Purl SOHO.COM
create *your* world!

VISIT OUR SHOP at 459 Broome Street,
New York, NY 10013 (212) 420-8796

For free patterns and tutorials,
visit our blog at WWW.PURLBEE.COM



SNOWFALL SWEATER

Jill Draper

Finished Size 33½ (35, 38, 41¼, 44¼)" bust circumference. Sweater shown measures 33½", modeled with 1–2" of ease.

Yarn Schulana Cortina Nuvoles (70% merino wool, 30% nylon; 55 yd [50 m]/1¼ oz [50 g]): #55 charcoal, 12 (13, 15, 16, 18) skeins. Yarn distributed by Skacel.

Needles Size 15 (10 mm): 16" and 24" circular (cir) and set of double-pointed (dps). Adjust needle size if necessary to obtain the correct gauge.

Notions Markers (m); 4 locking markers; stitch holders; tapestry needle.

Gauge 10½ sts and 15 rows = 4" in St st; 10 sts and 14 rows = 4" in snowflake lace patt.

NOTES

- The yoke and top portion of this sweater have scattered single snowflake motifs, and the bottom is an all-over snowflake lace pattern. The pattern is written with all shaping; for placement of the single snowflake

motifs on the body and sleeves, follow the placement diagrams. Place stitch markers on each side of the six stitches for each single snowflake motif as the number of stitches before the motifs may change from one row to the next as you work; remove markers after last row of each motif is worked.

YOKE

With 16" cir needle, CO 14 (14, 16, 16, 18) sts for back. Do not join.

Row 1: (WS) Purl.

Row 2: K1, yo, k12 (12, 14, 14, 16), yo, k1, then using the backward-loop method, CO 7 (7, 9, 9, 9) sts for right sleeve—23 (23, 27, 27, 29) sts.

Row 3: P23 (23, 27, 27, 29), CO 7 (7, 9, 9, 9) sts for left sleeve—30 (30, 36, 36, 38) sts.

Row 4: K7 (7, 9, 9, 9) for left sleeve, yo, k1, yo, k14 (14, 16, 16, 18) for back, yo, k1, yo, k7 (7, 9, 9, 9) for right sleeve, CO 20 (20, 22, 22, 24) sts for front—54 (54, 62, 62, 66) sts. Place marker (pm) and join in the rnd. Work in St st, foll Single Snowflake chart and snowflake placement diagrams, and work raglan shaping as foll:

Rnd 1: Knit.

Rnd 2: *Yo, k9 (9, 11, 11, 11), yo, k1 and place locking m on st, yo, k16 (16, 18, 18, 20), yo, k1 and place locking m on st; rep from * once more—62 (62, 70, 70, 74) sts. Cont to work yo inc on each side of marked sts every other rnd 10 (11, 11, 12, 14) more times—142 (150, 158, 166, 186) sts. Work 1 rnd even—yoke measures about 7¼ (7¼, 7¼, 8¼, 9¼)" from back neck CO.

Divide for sleeves:

Place 31 (33, 35, 37, 41) sts on holder for left sleeve, CO 4 (4, 6, 8, 6) sts for underarm, k40 (42, 44, 46, 52) back sts, place 31 (33, 35, 37, 41) sts on holder for right sleeve, CO 2 (2, 3, 4, 3) sts, pm for side, CO 2 (2, 3, 4, 3) sts, k40 (42, 44, 46, 52) front sts, remove m, then k2 (2, 3, 4, 3), pm for beg-of-rnd—88 (92, 100, 108, 116) sts rem for body.

BODY

Work even until piece measures about 4¼" from underarm. **Shape waist: Dec rnd:** *K2tog, knit to 2 sts before m, ssk; rep from * once more—4 sts dec'd. Rep Dec rnd every 6th rnd 2 more times—76 (80, 88, 96, 104) sts rem. Work 9 rnds even. **Inc rnd:** *K1, M1, knit to 1 st before m, M1, k1; rep from * once more—4 sts inc'd. Work 3 rnds even. Rep Inc rnd on next rnd—84 (88, 96, 104, 112) sts. Work 5 rnds even. Rep Inc rnd on next rnd—88 (92, 100, 108, 116) sts. Work 6 rnds even. **Next rnd:** Inc 2 (7, 8, 9, 10) sts evenly around—90 (99, 108, 117, 126) sts. Work Rnds 1–12 of Snowflake Lace chart 1 (1, 2, 2, 2) time(s), then work first 5 rnds 1 (1, 0, 0, 1) more time. BO all sts.

SLEEVE

With dps, starting at center of underarm CO, pick up and k2 (2, 3, 4, 3) sts, pick up

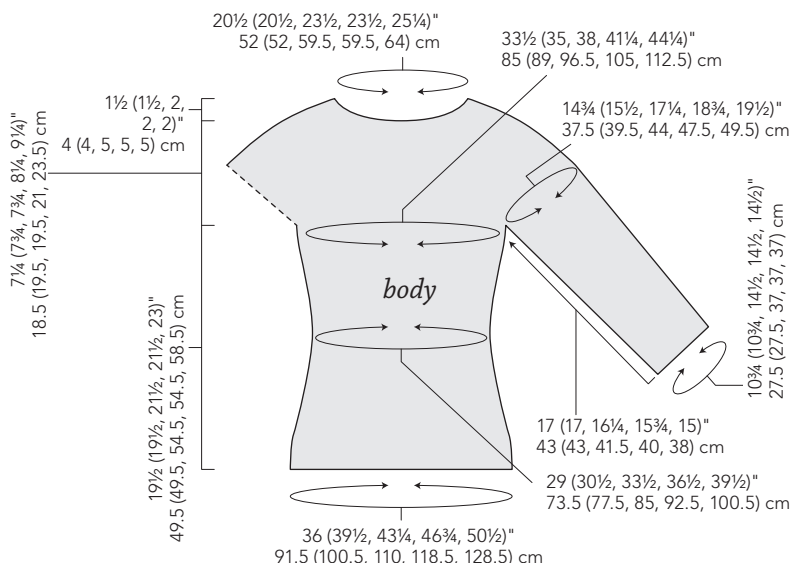

Single Snowflake

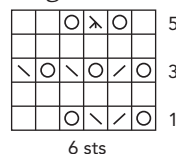

Snowflake Lace



R O W A N

Relax, Handknit, Create....

Mossdale by Martin Storey using *Lima*
Dalesmen



"Dalesmen has been put together in response to more and more men who are taking up needles, though I'm sure women would love to knit these designs for their menfolk too!"
Martin Storey

To find a store near you please visit our
new website www.knitrowan.com

Front & Back, sizes 33½ (35)''

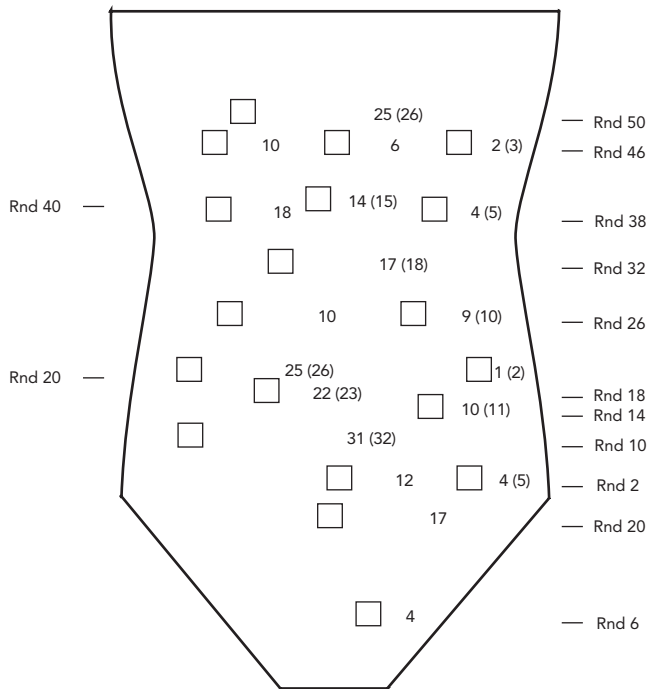

Right Sleeve, all sizes

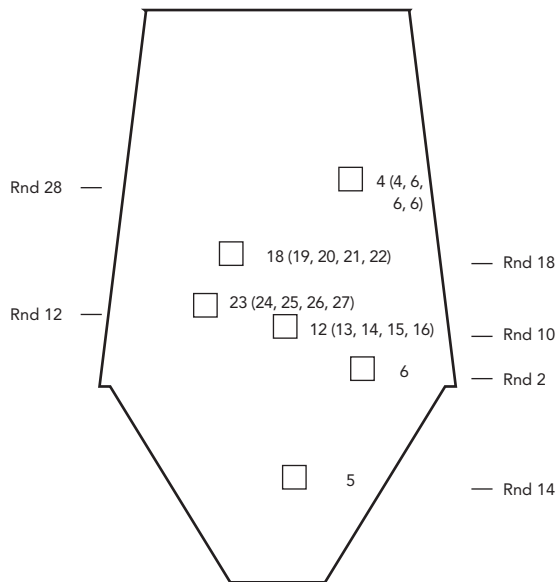

□ 6-st snowflake motif, worked over 5 rnds

Numbers on diagram indicate the number of stitches worked before a 6-stitch motif and between motifs on the first row of a motif. The numbers at the beginning of the row on the yoke indicate the number of stitches worked after the raglan yoke increases.

Front & Back, sizes 38 (41¼, 44¼)''

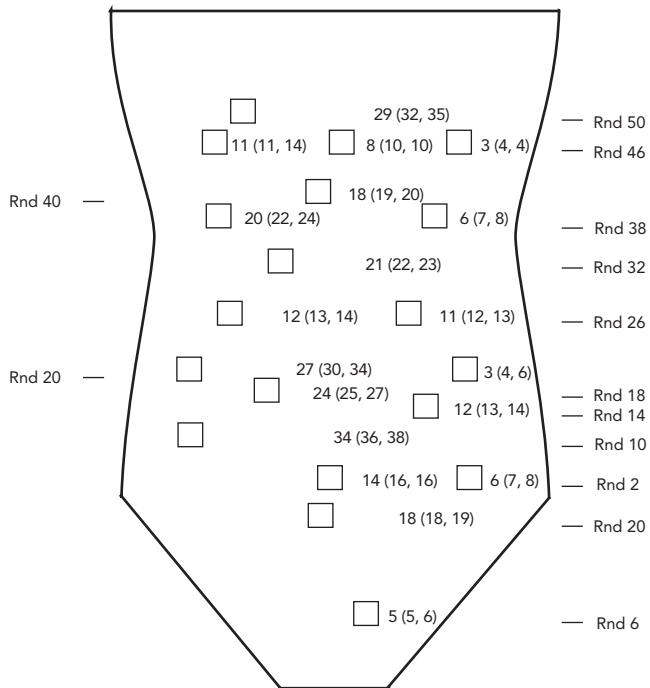

Left Sleeve, all sizes

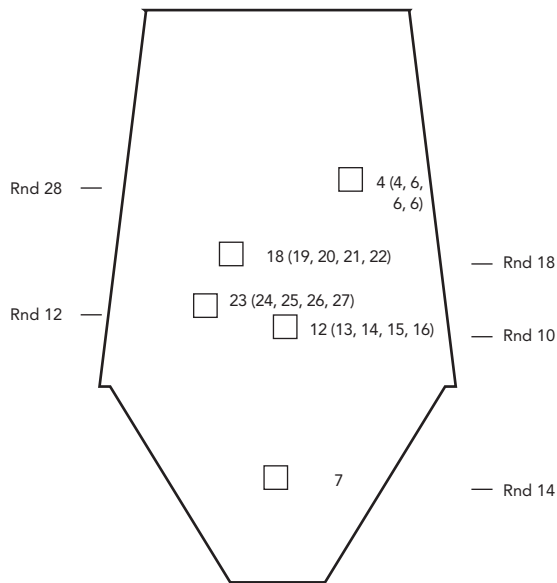

Authorized Louet North America Retailers



ALASKA

Fiber N Ice
PO Box 521215
4038 Casey Dr.
Big Lake, AK, 99652
(907) 892-8901 (ph)
dlmspinner@yahoo.com
www.fibernicealaska.com

CALIFORNIA

Purlescence Yarns
586 S. Murphy Ave.
Sunnyvale, CA, 94086
(408) 735-9276 (ph&tx)
info@purlescenceyarns.com
www.purlescenceyarns.com

Creative U Studios

26370 Diamond Place
Ste 509
Santa Clarita, CA 91350
(ph) 661-260-0800
amanda@creativeu.net
www.creativeu.net

Designer Hand Knits

6730 Rockton Ave
Riverside, CA 92506
(ph) 951-275-9711
(fx) 951-275-9899

COLORADO

Colorado Fiber Arts
121 Broadway Ave
Pueblo, CO, 81004
(719) 543-1161 (ph)
(719) 543-1890 (fx)
karen@coloradofiberarts.com
www.coloradofiberarts.com

CONNECTICUT

Woolworks Ltd.
154 Main St.
Putnam, CT, 06260
(860) 963-1228 (ph)
woolworks@snet.net
www.woolworksltd.com

Yarn LLC

910 Whalley Ave
Newhaven, CT 06515
(203) 389-3369 (ph)

GEORGIA

Creative Yarns
134 Speer Ave
Macon, GA, 31204
(478) 746-5648 (ph)
clo@creativeyarns.net
www.creativeyarns.net

The Whole Nine Yarns

8826 Main St
Woodstock, GA 30188
(ph) 678-494-5242
(fx) 678-494-5204
info@thewholenineyarns.com
www.thewholenineyarns.com

Only Ewe and Cotton Too

780 Mayfield Road, Ste B
Alpharetta, GA 30004
(ph) 770-740-0844
onlyewe@bellsouth.net
www.onlyeweandcottontoo.com

KENTUCKY

The Woolery
239 West Main St.
Frankfort, KY, 40601
(800) 441-9665 (ph)
(502)352-9802 (fax)
info@woolery.com
www.woolery.com

MASSACHUSETTS

Black Puris Yarn Shop
685 RT 6A
East Sandwich, MA, 02537
(508) 362-8880 (ph)
BlackPurisYarn@yahoo.com
www.blackpuris yarn.com

Petits Details LLC

599 High St
Medford, MA, 02155
(781) 775-9504 (ph)
(971) 228-4209
makesomething@
gatherhereonline.com
www.gatherhereonline.com

MICHIGAN

Thistledown Shoppe LLC
P.O. Box 52
419 N. St. Joseph St.
Suttons Bay, MI, 49682
(231) 271-9276 (ph)
thistledownshoppe@
yahoo.com

NEW HAMPSHIRE

The Elegant Ewe
75 South Main St, Unit 1
Concord, NH, 03301
(603) 226-0066 (ph)
info@elegantewe.com

NEW JERSEY

Yarn Bazaar
4 Victoria Place
West Windsor, NJ,
08550-5418
(877) 275-0475 (toll free ph)
(609) 897-9590 (fx)
joellen@yarnbazaar.com
www.yarnbazaar.com

Creative Knitworks

300 Fairview Ave
Westwood, NJ 07675
(ph) 201-664-5648
sharon@creativeknitworks.com
www.creativeknitworks.com

NEW YORK

Knitty City
208 West 79th St.
New York, NY 10024
(ph) 212-724-9596
pearl@knittycity.com
www.knittycity.com

The Yarn Company

2274 Broadway
New York, NY 10024
(ph) 212-787-7878
(fx) 212-202-4804
www.theyarncompany.com

NORTH CAROLINA

Hippie Chix Fiber Art
102 Indian Mound Road
Cullowhee, NC, 28723
(828) 293-2420 (ph)
(828) 293-0107 (fx)
gailjohnston@frontier.com
www.hippiechixfiberart.com

Sunflower Fibers

123 Anderson St.
Fayetteville, NC, 28301
(910) 223-1314 (ph)
info@sunflowerfibers.com
www.sunflowerfibers.com

NORTH DAKOTA

cedesigns and Yarn Shoppe
417 East Broadway
Bismarck, ND, 58501
(701) 471-2131 (ph)
cedesigns@
midconetwork.com

OHIO

BlackLocust Farm LLC
13225 New London
Eastern Spencer, OH, 44275
(330) 648-2720 (ph)
blacklocustwool@msn.com

OREGON

Knot Another Hat
16 Oak St. #202
Hood River, OR, 97031
(541) 308-0002 (ph)
sarah@knotanotherhat.com
www.knotanotherhat.com

The Websters Inc.

11 North Main Street
Ashland, OR, 97520
(541) 482-9801 (ph)
websters@mind.net

PENNSYLVANIA

GOSH Yarn It
303 Market St
Kingston, PA, 18704
(570) 287-9999 (ph)
info@goshyarnitshop.com
www.goshyarnitshop.com

Glory-ous Knits

15 Harris Circle
Watsonstown, PA, 17777
(570) 437-4139 (ph&tx)
customerservice@
glory-ousknits.com
www.glory-ousknits.com

TENNESSEE

Bliss Yarns
127 Franklin Road, Ste 140
Brentwood, TN 37027
(ph) 615-370-8717
(fx) 615-370-8745
dana@blissyarns.com
www.threadedblissyarns.com

TEXAS

Nancy's Knits
5300 N Braeswood Blvd,
#30
Houston, TX, 77096
(713) 661-9411 (ph)
nanknit@swbell.net
www.nancys-knits.com

Knitting in the Loop

2801 Bammel Lane
Houston, TX, 77098
(713) 942-7881 (ph)
jkaonett@sbcglobal.net
www.knittingintheLOOP.net

UTAH

Blazing Needles
1365 S 1100 E
Salt Lake City, UT, 84105
(801) 487-5648
cynthia@blazing-needles.com
www.blazing-needles.com

VERMONT

The Knitting Studio
97 State St
Montpelier, VT 05602
(ph) 802-229-2444
lee@vtknits.com
www.vtknits.com

WASHINGTON

Sheep's Clothing
560 Wisteria Street
Richland, WA, 99352
(509) 734-2484 (ph)

Yellow House Yarns

315-2nd St. NE
Puyallup, WA, 98372
(253) 226-7494 (ph)

CANADA

BRITISH COLUMBIA

Art of Yarn
3003 Pandosy Street
Kelowna, BC V1Y 1W3
(250) 717-3247 (ph)
(250) 762-5998 (fx)
info@artofyarn.com
www.artofyarn.com

Fun Knits Yarn Shop

Unit 2B 671 Plaza Rd
Quadra Island, BC
V0P-1N0
(250) 285-2751 (ph)
shelmack@telus.net
www.funknits.com

Urban Yarns Ventures Ltd.

4437 West 10th
Vancouver, BC V6R 2H8
(ph) 604-228-1122
(fx) 604-228-1133
knitting@urbanyarns.ca
www.urbanyarns.ca

Boutique De Laine

2534 Estevan Ave
Victoria, BC V8R 2S7
(ph) 250-592-9616
boutiquedelaine@shawbiz.ca

Beehive Wool Shop

1700 Douglas Street
Victoria, BC V8W 2G7
(ph) 250-385-2727
(fx) 250-385-2704
beehivewoolshop@telus.net
www.beehivewoolshop.com

ONTARIO

Sweet Yarns Inc
2354 Long Lake Rd
Sudbury, ON P3E5H5
(705) 919-4648 (ph)
sweetyarnsinc@gmail.com

Wool N' THINGS

1439 Youville Dr, Unit 20
Orleans (Ottawa), ON
K1C4M8
(613) 841-8689 (ph)
gisele@woolnthings.com
www.woolnthings.com

Serenity Knits

525 Brooker Ridge, Unit 101
Newmarket, ON L3X2M2
(ph) 905-710-3283
info@serenityknits.ca
www.serenityknits.ca

Pattern: Paige & Pamela
Yarn: MerLin Sport Weight
Color: #47 Terra Cotta
Designer: Trudy Van Stralen

Visit us online at www.louet.com
to download this and many other
patterns, or locate an authorized
retailer near you on this page or on
our website under "Find a Store".



north america

make it your own™

The unique wrapped construction of the Cortina Nuvole yarn makes even this long, bulky knitted sweater feel light but stay warm.



and knit 2 sts from the gap between CO sts and sleeve sts, k31 (33, 35, 37, 41) sleeve sts, pick up and knit 2 sts from the gap between sleeve sts and CO sts, pick up and knit 2 (2, 3, 4, 3) sts from CO—39 (41, 45, 49, 51) sts. Pm and join. Cont working single snowflake motifs as shown on diagrams (one for each sleeve), and at the same time, dec 1 st each side of m on first rnd, then every 4th rnd 0 (2, 0, 3, 6) times, every 6th rnd 5 (4, 0, 2, 0) times, every 8th rnd 0 (0, 3, 0, 0) times—27 (27, 37, 37, 37) sts rem. Work even until sleeve measures about 10½ (10½, 8½, 8, 7¼)" from underarm. **Next rnd:** Knit and dec 0 (0, 1, 1, 1) st—27 (27, 36, 36, 36) sts rem.

CUSTOMIZE IT

For this sweater's wintry look, you can place snowflakes wherever you like. Try just a few flakes cascading over a shoulder, a dense snowfall around the hem, or an asymmetrical grouping over one sleeve and shoulder.



Work Rnds 1–12 of Snowflake Lace chart 2 times, then work first 5 rnds 0 (0, 1, 1, 1) more time. BO all sts.

NECKBAND

With 16" cir needle and RS facing, pick up and knit 50 (50, 54, 54, 62) sts evenly around neck opening. Pm and join in the rnd. Knit 5 rnds. BO all sts.

FINISHING

Block pieces to measurements. Weave in ends.

Jill Draper earned her BFA in Fashion Design from Pratt Institute. One of Jill's current goals is to make sure everyone has at least one handmade garment in the closet. To this end, she teaches lots of classes, as you can see at www.doubleknotstudio.com. And check out her hand-dyed yarns at www.jilldraper.com.

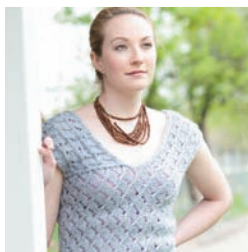

STROBILUS PULLOVER

Rachel Erin

Finished Size 30 (33, 36, 39, 42, 45)" bust circumference. Vest shown measures 33", modeled with 2" of positive ease.

Yarn Classic Elite Yarns Ariosa (90% superfine merino, 10% cashmere; 87 yd [80 m]/1¼ oz [50 g]): #4803 foam, 5 (6, 6, 7, 8, 8) balls.

Needles Size 9 (5.5 mm): 24" circular (cir). Adjust needle size if necessary to obtain the correct gauge.

Notions Markers (m); removable marker; stitch holders; tapestry needle.

Gauge 16 sts and 21 rnds = 4" in spiraling lace patt.

NOTES

- This stitch pattern and yarn grow significantly when blocked, so it is essential to block a swatch and make sure that the final gauge matches.
- Because of the bias in the stitch

pattern, waist shaping can easily be formed when blocking.

- To alter length, add or subtract repeats to the body. Each repeat adds about 2", depending on how much shaping is blocked into the sweater.
- It is helpful to label the stitch holders with their section (e.g., left back join) when dividing the body for the shoulders.
- When joining the shoulder to the body, be sure that each decrease and yarnover is paired when working the stitch pattern. If you do not have enough stitches to work one of each in pattern, work stitches in stockinette stitch instead.

Stitch Guide

Spiraling Lace: (multiple of 6 sts)

Rnd 1: *K4, k2tog, yo; rep from *.

Rnd 2: *K3, k2tog, k1, yo; rep from *.

Rnd 3: *K2, k2tog, k2, yo; rep from *.

Rnd 4: *K1, k2tog, k3, yo; rep from *.

Rnd 5: *K2tog, k4, yo; rep from *.

Rnd 6: Remove m, sl first st of rnd pwise with yarn in back (wyb), place marker (pm) for new beg of rnd, *yo, k4, k2tog; rep from *.

Rnd 7: *K1, yo, k3, k2tog; rep from *.

Rnd 8: *K2, yo, k2, k2tog; rep from *.

Rnd 9: *K3, yo, k1, k2tog; rep from *.

Rnd 10: *K4, yo, k2tog; rep from *.

Rep Rnds 1–10 for patt.

Slanting Lace: (multiple of 6 sts)

Row 1: (RS) *Yo, k4, k2tog; rep from *.

Row 2: *P2tog, p3, yo, p1; rep from *.

Row 3: *K2, yo, k2, k2tog; rep from *.

Row 4: *P2tog, p1, yo, p3; rep from *.

Row 5: *K4, yo, k2tog; rep from *.

Row 6: *P2tog, p4, yo; rep from *.

Row 7: *K1, yo, k3, k2tog; rep from *.

Row 8: *P2tog, p2, yo, p2; rep from *.

Row 9: *K3, yo, k1, k2tog; rep from *.

Row 10: *P2tog, yo, p4; rep from *.

Rep Rows 1–10 for patt.

BODY

CO 120 (132, 144, 156, 168, 180) sts. Pm for center back and join in the rnd. Work Rnds 1–10 of spiraling lace patt (see Stitch Guide) 9 times.

Sizes 30 (36, 42)" only:

Set-up for shoulders: (RS) Remove m, sl 2 pwise wyb, M1, work Row 1 of slanting lace patt (see Stitch Guide) over 24 (30, 36) sts, k1, place previous 27 (33, 39) sts on holder for left-back join, BO 8 sts for left underarm, M1, work Row 1 of



**WE'VE MADE A LOT OF BEAUTIFUL THINGS OVER 133 YEARS.
THE FRIENDSHIPS ARE OUR FAVORITES.**

Visit LionBrand.com for over 4,000 free patterns.



LionBrand.com

slanting lace patt over 24 (30, 36) sts, k1, place previous 27 (33, 39) sts on holder for left-front shoulder, sl 1 pwise wyb, M1, work Row 1 of slanting lace patt over 24 (30, 36) sts, k1, place previous 27 (33, 39) sts on holder for right-front join, BO 8 sts for right underarm, M1, work Row 1 of slanting lace patt over 24 (30, 36) sts, knit first sl st from beg of rnd—27 (33, 39) sts each section.

Sizes 33 (39, 45)" only:

Set-up for shoulders: (RS) Remove m,

sl 4 pwise wyb, work Row 1 of slanting lace patt (see Stitch Guide) over 24 (30, 36) sts, k2, place previous 28 (34, 40) sts on holder for left-back join, BO 10 sts for left underarm, sl 1 more st pwise wyb (2 sts on right needle after BO), work Row 1 of slanting lace patt over 24 (30, 36) sts, k2, place previous 28 (34, 40) sts on holder for left-front shoulder, sl 2 pwise wyb, work Row 1 of slanting lace patt over 24 (30, 36) sts, k2, place previous 28 (34, 40) sts on holder for right-front join, BO 10 sts for right underarm, sl 1 more st pwise wyb (2 sts on right needle after BO), work Row 1 of slanting lace patt over 24 (30, 36) sts, knit 2 sl sts from beg of rnd—28 (34, 40) sts each section.

All sizes:

Right shoulder: Work back and forth over right back shoulder sts as foll: (WS) Sl 1 (2, 1, 2, 1, 2) pwise with yarn in front (wyf), work Row 2 of slanting lace patt over 24 (24, 30, 30, 36, 36) sts, p2. **Next row:** (RS) Sl 2 pwise wyb, work Row 3 of slanting lace patt over 24 (24, 30, 30, 36, 36) sts, k1 (2, 1, 2, 1, 2). Cont in patt until Rows 1–10 of slanting lace patt have been worked 6 (6, 6, 7, 7, 7) times. At end of last row, sl last st pwise wyf and place a m on it; do not turn. **Join shoulder to body:** With WS facing and working from left to right, transfer held right-front join sts onto left end of cir needle, making sure armhole is not twisted—all back shoulder sts will be on right needle and all front join sts will be on left needle. Sl last st on right needle (marked st) to left needle, p3tog, turn—52 (54, 64, 66, 76, 78) sts rem. **Next row:** (RS) Sssk, work in patt to end of row (see Notes)—2 sts dec'd.

Next row: Work to marked st, p3tog,

turn—2 sts dec'd. Rep last 2 rows 10 (10, 13, 13, 16, 16) more times, then work RS row once more—6 (8, 6, 8, 6, 8) sts rem.

Sizes 30 (36, 42)" only:

Next row: (WS) Sl 1 pwise wyf, p1, p3tog, turn—4 sts rem. **Next row:** Sssk—2 sts rem. **Next row:** P2tog—1 st rem. Fasten off last st.

Sizes 33 (39, 45)" only:

Next row: (WS) Sl 2 pwise wyf, p1, p3tog, turn—6 sts rem. **Next row:** Ssk, k2—5 sts rem. **Next row:** Sl 2 pwise wyf, p3tog, turn—3 sts rem. **Next row:** Sssk—1 st rem. Fasten off last st.

LEFT SHOULDER

Transfer held left-front shoulder sts onto needles. With WS facing, join new yarn and work as for right shoulder.

FINISHING

Weave in ends. Block to measurements, incorporating waist shaping if desired.

With her husband and two daughters, *Rachel Erin* is moving to Rome for a year. She looks forward to learning Italian, designing with new yarns, and experiencing a snowless winter. You can follow her knitting as well as her other adventures at www.rachelerin.com.

Tech Tip

The nature of this lace pattern forces the end of round to move by one full widthwise repeat for every full row repeat. Lengthen or shorten the top by working as many or as few repeats of the lace pattern as you like before splitting to form the shoulders, but remember to stop after a full repeat has been completed.

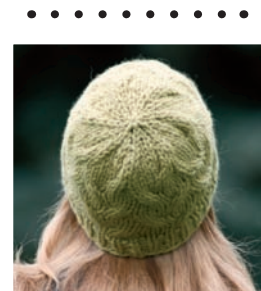
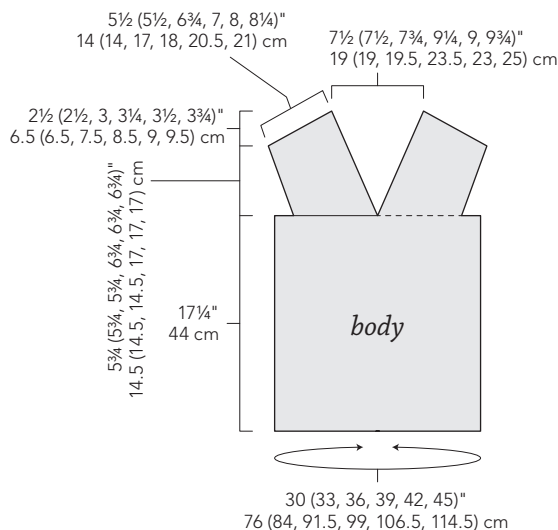

SHADOW TUQUE

Lee Juvan

Finished Size 18¾" brim circumference (will stretch to 23" head circumference) and 7¼ (8¼)" tall. Hat shown in smaller size.

Yarn Classic Elite Yarns Toboggan (70% merino, 30% superfine baby alpaca; 87 yd [80 m]/3½ oz [100 g]): #6715 leaf, 1 skein.

Needles Sizes 9 (5.5 mm) and 10½ (6.5 mm): 16" circular (cir). Size 10½ (6.5 mm): set of double-pointed (dnp). Adjust needle size if necessary to obtain the correct gauge.

Notions Marker (m); cable needle (cn); tapestry needle.

LOVE THE **COLOR**
LOVE THE YARN

INTRODUCING MALABRIGO BOOK 3,
RASTA NECKWARMER, COLOR 862 PIEDRAS.

malabrigo



www.MalabrigoYarn.com

Gauge 12 sts and 19 rnds = 4" in shadow cable patt on larger needle.

HAT

With smaller cir needle, CO 56 sts. Place marker (pm) and join in the rnd. Work in k1, p1 rib for 1¼ (1½)". Change to larger cir needle. Work Rows 1–8 of Shadow Cable chart 2 (3) times, then work first 4 rows 1 (0) more time—piece measures about 5½ (6½)" from CO. Knit 1 rnd. **Shape crown:**

Note: Change to dpn when necessary.

Rnd 1: *K2, k2tog; rep from * around—42 sts rem.

Rnds 2, 4, and 6: Knit.

Rnd 3: *K1, k2tog; rep from * around—28 sts rem.

Rnd 5: *K2tog; rep from * around—14 sts rem.

Rnd 7: *K2tog; rep from * around—7 sts rem.

FINISHING

Cut yarn, leaving a 10" tail. Thread tail through rem sts, pull tight to gather, and fasten off on WS. Weave in ends.

A columnist for *Knittyspin*, **Lee Juvan** spins, knits, designs, and teaches fiber arts to a new generation of enthusiasts at Westover School in Connecticut.

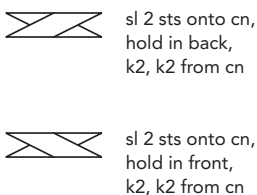

Shadow Cable

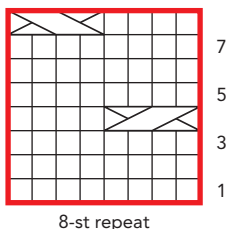

CARDIGAN BAY JACKET
Carol Feller

Finished Size 31¼ (34, 38½, 42, 47¼, 51)" bust circumference, buttoned. Cardigan shown measures 34".

Yarn Rowan Big Wool (100% merino wool; 87 yd [80 m]/3½ oz [100 g]): #00061 concrete, 8 (8, 9, 10, 11, 12) skeins. Yarn distributed by Westminster Fibers.

Needles Size 15 (10 mm): 40" circular (cir) and set of double-pointed (dpn). Adjust needle size if necessary to obtain the correct gauge.

Notions Markers (m); stitch holders; tapestry needle; safety pin; size M/15 (10 mm) crochet hook; 8 (8, 8, 9, 9, 9) 1" buttons.

Gauge 9 sts and 14 rows = 4" in moss st.

Stitch Guide

Moss Stitch (over any number of sts)

Row 1: (WS) *K1, p1; rep from *.

Row 2: Knit the knit sts and purl the purl sts.

Row 3: *P1, k1; rep from *.

Row 4: Knit the knit sts and purl the purl sts.

Rep Rows 1–4 for patt.

YOKE

With cir needle, CO 38 (40, 46, 46, 50, 50) sts. Do not join. **Raglan set-up row:** (WS) Work Row 1 of moss st (see Stitch Guide) over 5 (5, 7, 7, 9, 9) sts, p1 (seam st), place marker (pm), work 5 (5, 5, 5, 3, 3) sts in moss st, p1 (seam st), pm, work 13 (15, 17, 17, 21, 21) sts in moss st, p1 (seam st), pm, work 5 (5, 5, 5, 3, 3) sts in moss st, p1 (seam st), pm, work 6 (6, 8, 8, 10, 10) sts in moss st.

Row 1: (RS) *Work row 2 of moss st to m, yo, sl m, k1, yo; rep from * 3 more times, work in moss st to end—8 sts inc'd.

Row 2: (WS) *Work Row 3 of moss st to 2 sts before m, k1, p1, sl m, k1; rep from * 3 more times, work in moss st to end.

Row 3: *Work Row 4 of moss st to 1 st before m, p1, yo, sl m, k1, yo, p1; rep from * 3 more times, work in moss st to end—8 sts inc'd.

Row 4: *Work Row 1 of moss st to 1 st before m, p1, sl m; rep from * 3 more times, work in moss st to end.

Rep last 4 rows 4 (4, 5, 6, 6, 7) more times—118 (120, 142, 158, 162, 178) sts. Rep first 2 rows 0 (1, 0, 0, 1, 1) time—118 (128, 142, 158, 170, 186) sts total: 16 (17, 20, 22, 25, 27) sts each front; 26 (28, 30, 34, 34, 38) sts each sleeve; 34 (38, 42, 46, 52, 56) sts for back. Piece measures about 6 (6½, 7¼, 8¼, 8¼, 10)" from CO. **Divide for armholes:** (RS) *Work in moss st to m, remove m, place 26 (28, 30, 34, 34, 38) sts on a holder for sleeve, sl m (side m); rep from * once more, work in moss st to end—66 (72, 82, 90, 102, 110) sts rem for body.

BODY
Work in moss st until piece measures 5 (5, 5, 4½, 4, 3½)" from underarm, ending

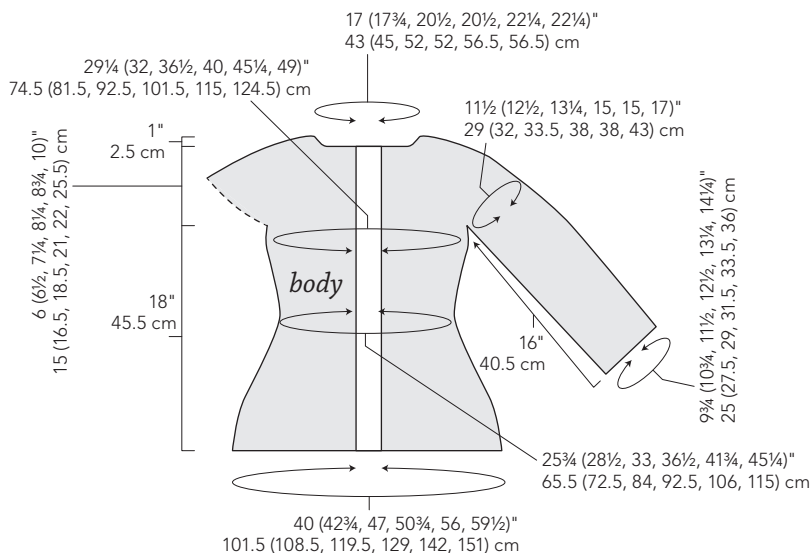

By Knitters, for Knitters

Since 2002, we've made it our mission to offer the best quality knitting needles at affordable prices. We're so confident you'll love our needles that we back them up with a no-hassle return policy. Shop online at KnitPicks.com or at your local yarn store.

We're here to help, ask a fellow knitter!
knitter@knitpicks.com

Smooth Joins • Perfect Points • Flexible Cables

Knit Picks®

The color purple and Knitting in Waves of Color with Harmony™ are trademarks of Crafts Americana Group Inc.

with a WS row. **Waist dec row:** (RS) *Work to 2 sts before m, k2tog (or p2tog to maintain patt), sl m, p2tog (or k2tog to maintain patt); rep from * once more, work in patt to end of row—4 sts dec'd. Work 7 rows even. Rep waist dec row on next row—58 (64, 74, 82, 94, 102) sts rem. Remove side m. Work even until piece measures 10½ (10½, 10½, 10, 9½, 9)" from underarm, ending with a WS row. **Inc row:** (RS) Work 6 (6, 8, 9, 10, 11) sts in patt, yo, pm for dart (pdm), k1, yo, work 17 (19, 21, 24, 28, 30) sts in patt, yo, pdm, k1, yo, work 8 (10, 12, 12, 14, 16) sts, yo, pdm, k1, yo, work 17 (19, 21, 24, 28, 30) sts in patt, yo, pdm, k1, yo, work in patt to end—66 (72, 82, 90, 102, 110)

CUSTOMIZE IT

"This design is very easy to modify. Because it's knitted top down, you can easily add or remove length to the sleeves and body depending on your personal style and yarn amounts. Below the waist of this design, I've worked four sets of yarnovers to create room at the hips for movement. However, if you would rather keep the design straighter at this point, adding just two sets of yarnovers will create narrower hips. In this sample, I've used both a belt and buttons to fasten the cardigan. However, either could be used alone. You could use a belt without buttons for a wrap-around cardigan or omit the belt in favor of button fastenings."

—Carol Feller



sts. **Next row:** (WS) *Work in patt to last st before dm (working new sts into patt), p1, sl m; rep from * 3 more times, work in patt to end. **Inc row:** (RS) *Work in patt to last st before dm, yo, sl m, k1, yo; rep from * 3 more times—8 sts inc'd. Rep last 2 rows 2 more times—90 (96, 106, 114, 126, 134) sts. Remove dm. Work even in moss st until piece measures 16" from underarm, ending with a WS row. Work in garter st for 2", ending with a WS row. BO all sts loosely.

SLEEVES

Place 26 (28, 30, 34, 34, 38) sleeve sts on dpn. Beg at center of underarm, join yarn and pm for beg-of-rnd. Work in moss st as established for 13 (13, 13, 8, 13, 8) rnds.

Dec rnd: K2tog (or p2tog to maintain patt), work to last 2 sts, p2tog (or k2tog to maintain patt)—2 sts dec'd. Rep last 14 (14, 14, 9, 14, 9) rnds 1 (1, 1, 2, 1, 2) more time(s)—22 (24, 26, 28, 30, 32) sts rem. Work even in patt until sleeve measures 14" from underarm. Work in garter st for 2". BO all sts loosely.

FINISHING

Collar: With RS facing and cir needle, pick up and knit 38 (40, 46, 46, 50, 50) sts around neck. Knit 3 rows. **Dec row:** (RS) *K4, k2tog; rep from * to last 2 (4, 4, 4, 2, 2) sts, k2 (4, 4, 4, 2, 2)—32 (34, 39, 39, 42, 42) sts rem. Work even in garter until collar measures 2" from picked-up row, ending with a WS row. BO all sts loosely. **Buttonband:** With RS facing and cir needle, pick up and knit 60 (62, 64, 66, 68, 72) sts along left front. Knit 7 rows. BO all sts. **Buttonband:** With RS facing, pick up and knit 60 (62, 64, 66, 68, 72) sts along right front. Knit 4 rows.

Size 31¼" only: K2, pm, k3 (buttonhole), pm, [k5, pm, k3 (buttonhole), pm, k4, pm, k3 (buttonhole), pm] 3 times, k5, pm, k3

(buttonhole), pm, k2.

Size 34" only: K2, pm, k3 (buttonhole), pm, k4, pm, k3 (buttonhole), pm, [k5, pm, k3 (buttonhole), pm] 6 times, k2.

Sizes 38½ (51)" only: K2, pm, k3 (buttonhole), pm, [k5, pm, k3 (buttonhole), pm] 7 (8) times, k2 (3).

Size 42" only: K2, pm k3 (buttonhole), pm, *k5, pm, k3 (buttonhole), pm, [k4, pm, k3 (buttonhole), pm] twice; rep from * once more, k5, pm, k3 (buttonhole), pm, k4, pm, k3 (buttonhole), pm, k2.

Size 47¼" only: K2, pm, k3 (buttonhole), pm, [k5, pm, k3 (buttonhole), pm, k4, pm, k3 (buttonhole), pm] 4 times, k3.

Buttonhole row: (RS) *Work to buttonhole m, work 3-st one-row buttonhole (see Glossary); rep from * 7 (7, 7, 8, 8, 8) more times, knit to end. Work 1 row even. BO all sts in patt.

Belt:

Note: Belt should measure about 40" longer than natural waist. Adjust CO sts to change desired belt length. CO 150 (156, 166, 174, 186, 194) sts. Knit 6 rows. BO all sts.

Belt loops: (Make 2)

With crochet hook, ch 7, then fasten off, leaving a long tail at each end. Sew top and bottom of each belt loop to the side of the cardigan at the narrowest point of the waist. Take care that they are level. Sew underarm gaps. Weave in ends. Block to measurements.

Carol Feller is an independent knitwear designer living in Cork, Ireland. Carol's patterns have been widely published in books and magazines. To see her self-published patterns, visit www.stolenstitches.com. And look for her first book, *Contemporary Irish Knits*, due from Wiley this fall.





knit, Swirl!

UNIQUELY FLATTERING
ONE PIECE, ONE SEAM
SWIRL JACKETS

SANDRA McIVER

Photography by
ZOE LONERGAN

Foreword by
CAT BORDHI

knit, Swirl! BY SANDRA McIVER *uniquely flattering, one piece, one seam swirl jackets*

SEASTACK PUBLISHING & WWW.KNITSWIRL.COM & DISTRIBUTED BY UNICORN BOOKS, GEMINI FIBRES & SEARCH PRESS



knit. sock. love.

by COOKIE A

one
leg
PRESS

Distributed by • Unicorn Books in the US • Search Press in the UK • Gemini Fibres in Canada

www.onelegpress.com



KNITTING *interrupted*

*Pretty flourishes add
just enough detail to
simple knits.*



A double moss-stitch underlay supports and stabilizes a wide collar



Collars and cuffs in a tonal bouclé add textural contrast



Deep, wide three-quarter sleeves gain support from another double moss-stitch underlay

LARISSA GIBSON'S SOLSTICE JACKET

combines a polished merino wool and a silk bouclé in the same shade in a simple trimmed jacket. A high, broad collar, a cropped waist and sleeves, and lush trim add up to an easy knit with vintage style. **PAGE 60. YARN** Blue Moon Fiber Arts Gaea and Silk Loops



KNITTING *interrupted*

The **GEMINI CARDIGAN** tweaks the classic stockinette cardigan with asymmetrical collar points and simple garter-stitch welts. **KATYA FRANKEL** works the cardigan in one piece for minimal finishing. **PAGE 62.** **YARN** Brown Sheep Company Lanaloft Worsted

A wide, off-center buttonband in garter stitch turns over to become a lapel on the cardigan's right side and a reverse collar on the left

Dense garter stitch gives shape and stretch to collar pieces

Staccato lines of garter stitch add structure to an otherwise unadorned fabric

KNITTING
interrupted

LAURA GRUTZECK pairs honeycomb slip stitch with double-knitted stockinette for a classic jacket that doesn't require a single purl stitch. Fully fashioned pieces and careful finishing give the **HONEYCOMB JACKET** a tailored look. **PAGE 66. YARN** Jo Sharp Silkroad DK Tweed



A tall double-knitted collar looks good both closed and open



An asymmetrical closure adds modern edge to a classic piece



Double-knitted hems and front bands add polished finish





SOLSTICE JACKET

Larissa Gibson

Finished Size 36 (40½, 45, 49, 53)" bust circumference, buttoned. Jacket shown measures 36", modeled with 2–4" of ease.

Yarn Blue Moon Fiber Arts Gaea (100% certified organic merino wool; 305 yd [278 m]/8 oz [226 g]): chocolate moose (MC), 3 (4, 4, 5, 5) skeins. Blue Moon Fiber Arts Silk Loops (54% kid mohair, 26% silk, 15% wool, 5% nylon; 390 yd [356 m]/8 oz [226 g]): chocolate moose (CC), 1 skein.

Needles Sizes 9 (5.5 mm) and 10 (6 mm): 24" circular (cir). Adjust needle sizes if necessary to obtain the correct gauge.

Notions Stitch holders; tapestry needle; two 2" buttons; one clasp closure.

Gauge 15 sts and 22 rows = 4" in St st on smaller needle using MC; 16 sts and 20 rows = 4" in St st on larger needle using CC.

Stitch Guide

Double Moss Stitch (multiple of 4 sts)

Rows 1 and 2: *K2, p2; rep from * to end.

Rows 3 and 4: *P2, k2; rep from * to end.

Rep Rows 1–4 for patt.

BACK

With MC and smaller needle, CO 68 (76, 84, 92, 100) sts. Do not join. Work in Double Moss st (see Stitch Guide) for 8 rows, ending with a WS row. Change to St st and work until piece measures 12 (12, 13, 13, 13)" from CO, ending with a WS row.

Shape armholes: BO 4 (4, 4, 5, 6) sts at beg of next 2 rows—60 (68, 76, 82, 88) sts rem. Work 2 (2, 0, 0, 0) rows even. **Dec row:** (RS) K3, ssk, knit to last 5 sts, k2tog, k3—2 sts dec'd. Rep Dec row every 4th row 2 (1, 0, 0, 0) times, then every other row 12 (16, 20, 22, 24) times—30 (32, 34, 36, 38) sts rem. Work 1 row even. Place sts on a holder. Armhole measures about 7 (7½, 8, 8¾, 9½)".

LEFT FRONT

With MC and smaller needle, CO 34 (38, 42, 46, 50) sts. Do not join. **Beg Double Moss st:**

Row 1: (RS) P2, *k2, p2; rep from * to end.

Row 2: K2, *p2, k2; rep from * to end.

Row 3: Rep Row 2.

Row 4: Rep Row 1.

Rep Rows 1–4 once more. Cont working Double Moss st on 4 sts at center front edge (end of RS rows and beg of WS rows) and work in St st on rem sts until piece measures 12 (12, 13, 13, 13)" from CO, ending with a WS row. **Note:** Armhole and neck shaping occur at the same time. Read through the foll instructions before beg to knit. **Shape armhole:** (RS) BO 4 (4, 4, 5, 6) sts, work to end—30 (34, 38, 41, 44) sts rem. Work 3 (3, 1, 1, 1) row(s) even. **Dec row:** (RS) K3, ssk, work in patt to end—1 st dec'd. Rep Dec row every 4th row 2 (1, 0, 0, 0) time(s), then every other row 12 (16, 20, 22, 24) times. Work 1 row even. **At the same time,** when armhole measures about 2¼ (2½, 2½, 3, 3¾)", end with a WS row, then shape neck as foll: Dec 1 at neck edge at end of every RS row 11 (12, 13, 14, 15) times. When all shaping is complete—4 sts rem. Place sts on a holder. Armhole measures about 7 (7½, 8, 8¾, 9½)".

RIGHT FRONT

With MC and smaller needle, CO 34 (38, 42, 46, 50) sts. Do not join. **Beg Double Moss st:**

Row 1: (RS) K2, *p2, k2; rep from * to end.

Row 2: P2, *k2, p2; rep from * to end.

Row 3: Rep Row 2.

Row 4: Rep Row 1.

Rep Rows 1–4 once more. Cont working Double Moss st on 4 sts at center front edge (beg of RS rows and end of WS rows) and work in St st on rem sts until piece measures 12 (12, 13, 13, 13)" from CO, ending with a RS row. **Note:** Armhole and neck shaping occur at the same time. Read through the foll instructions before beg to knit. **Shape armhole:** (WS) BO 4 (4, 4, 5, 6) sts, work to end—30 (34, 38, 41, 44) sts rem. Work 2 (2, 0, 0, 0) rows even. **Dec row:** (RS) Work in patt to last 5 sts, k2tog, k3—1 st dec'd. Rep Dec row every 4th row 2 (1, 0, 0, 0) time(s), then every other row 12 (16, 20, 22, 24) times. Work 1 row even. **At the same time,** when armhole measures about 2¼ (2½, 2½, 3, 3¾)", end with a WS row, then shape neck as foll: Dec 1 at neck edge at beg of every RS row 11 (12, 13, 14, 15) times. When all shaping is complete—4 sts rem. Place sts on a holder. Armhole measures about 7 (7½, 8, 8¾, 9½)".

SLEEVES

Cuff: With CC and larger needle, CO 52 (56, 60, 64, 72) sts. Do not join. Work in Double Moss st for 4 rows. **Next row:** Purl. **Next row:** Knit. Rep last 2 rows until cuff measures 4½" from CO, ending with a knit row. **Next row:** (WS of cuff) Knit 1 row for turning ridge. **Next row:** (RS of cuff) Knit, dec 4 sts evenly across—48 (52, 56, 60, 68) sts rem.

Change to MC and smaller needle. **Note:** RS of sleeve will face WS of cuff so when cuff is folded back, RS will show. Beg with a RS row (of sleeve), work in Double Moss st for 32 rows, ending with a WS row. Beg

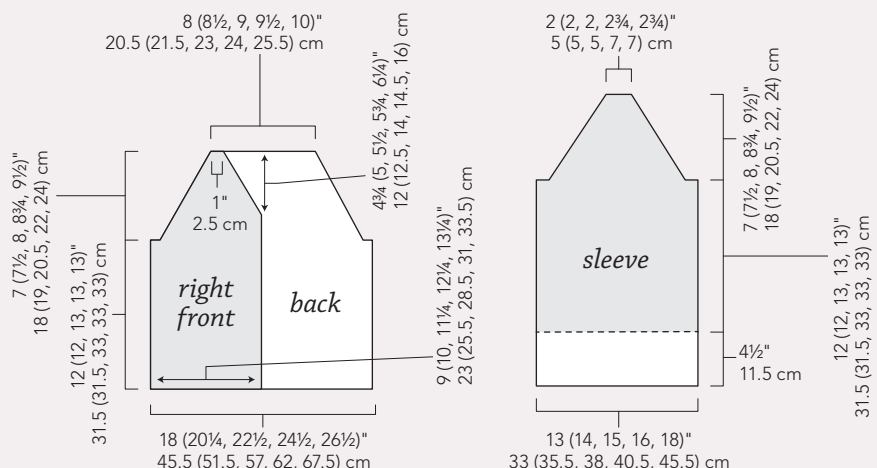



with a knit row, work in St st until sleeve measures 12 (12, 13, 13, 13)" from beg of MC section, ending with a WS row. **Shape armhole:** BO 4 (4, 4, 5, 6) sts at beg of next 2 rows—40 (44, 48, 50, 56) sts rem. Work 2 rows even. **Dec row:** (RS) K3, ssk, knit to last 5 sts, k2tog, k3—2 sts dec'd. Rep Dec row every 4th row 1 (1, 0, 2, 1) times, then every other row 14 (16, 19, 17, 21) times—8 (8, 8, 10, 10) sts rem. Work 1 row even. Place sts on a holder.

FINISHING

Block pieces to measurements. Sew sleeves into armholes. Sew sleeve and side seams.

COLLAR

With RS of jacket facing, MC and smaller needle, pick up and knit 23 (24, 27, 28, 31) sts along right front neck, knit sts from holders as foll: 4 sts from right front, 8 (8, 8, 10, 10) sts from right sleeve, 30 (32, 34, 36, 38) sts from back, 8 (8, 8, 10, 10) sts from left sleeve and 4 sts from left front, then pick up and knit 23 (24, 27, 28, 31) sts along left front neck—100 (104, 112, 120, 128) sts total. Work in Double Moss st until collar measures 3", ending with WS of jacket facing. **Buttonhole row:** (RS of jacket) Work 8 sts, BO 6 sts, work to end. **Next row:** (WS) Work to buttonhole, using the backward-loop method, CO 6 sts, work to end. Work even until collar measures 5" from pick-up row, ending with WS of jacket facing. Change to larger needle and CC. **Next row:** (RS) Knit, inc 6 sts evenly across—106 (110, 118, 126, 134) sts. **Next row:** Knit. **Next row:** Purl. Rep last 2 rows until CC section measures 2", ending with a knit row. **Next row:** P9, BO 5 sts, purl to last 14 sts, BO 5 sts, purl to end. **Next row:** Knit, CO 5 sts over each buttonhole. Work even until CC section measures 4¾", then work in Double Moss st (as for right front) until CC section measures 5". BO all sts. Block collar. Sew buttons on left front collar, stacked, with one on RS and one on WS, and aligned with buttonhole on CC section. Stabilize buttonholes using buttonhole stitch. Fold sleeve cuffs to RS and tack down. Weave in ends. Sew clasp on fronts, 4" down from beg of neck shaping.

Larissa Gibson is having a blast as the assistant editor of *Interweave Knits*. This is her first published pattern.

• • • • •



GEMINI CARDIGAN

Katya Frankel

Finished Size 30¼ (34¼, 38¼, 42¼, 46¼, 50¼)" bust circumference, buttoned. Cardigan shown measures 34¼", modeled with slight positive ease.

Yarn Brown Sheep Company Lanaloft Worsted (100% wool; 160 yd [146 m]/3½ oz [100 g]): #LL255W rose marquee, 5 (5, 6, 7, 7, 8) skeins.

Needles Size 8 (5 mm): 36" circular (cir) and set of double-pointed (dnp). Adjust needle size if necessary to obtain the correct gauge.

Notions Markers (m); stitch holders; tapestry needle; six large snaps.

Gauge 16 sts and 24 rows = 4" in St st.

NOTES

- Each front neck is shaped differently (see the schematic diagram).

Stitch Guide

Sizes 30¼ (38¼, 46¼)" only:

Dash Stitch (multiple of 10 sts + 4)

Row 1: (RS) P2, *p3, k4, p3; rep from * to last 2 sts, end p2.

Rows 2, 4, and 6: Purl.

Rows 3 and 7: Knit.

Row 5: K2, *k2, p6, k2; rep from * to last 2 sts, end k2.

Row 8: Purl.

Rep Rows 1–8 for patt.

Sizes 34¼ (42¼, 50¼)" only:

Dash Stitch (multiple of 10 sts)

Row 1: (RS) *P3, k4, p3; rep from * to end.

Rows 2, 4, and 6: Purl.

Rows 3 and 7: Knit.

Row 5: *K2, p6, k2; rep from * to end.

Row 8: Purl.

Rep Rows 1–8 for patt.

Raglan dec row: (RS) *Work to 3 sts before m, ssk, k1, sl m, k1, k2tog; rep from * 3 more times, work to end—8 sts dec'd; 1 st on each front, 2 sts each on back and sleeves.

Body dec row: (WS) *Work to 3 sts before m, p2tog, p1, sl m, purl to next m, sl m, p1, ssp; rep from * once more, work to end—4 sts dec'd; 1 st on each front, 2 sts on back.

BODY

With cir needle, CO 129 (145, 161, 177, 193, 209) sts. Do not join. Work in garter st for 4 rows, ending with a WS row.

Set-up row: (RS) K14 (14, 16, 16, 18, 18), place marker (pm) for right front band, work Row 1 of dash st (see Stitch Guide) over 114 (130, 144, 160, 174, 190) sts,

k1. **Next row:** (WS) P1, work dash st to m, sl m, knit to end. Keeping right front band in garter st, 1 st at left front edge in St st, and rem sts in dash st, work even for 30 more rows, ending with a WS row.

Shape waist: Next row: (RS) Knit to m, sl m, k4 (6, 6, 8, 8, 10), *pm, k2tog, k28 (32, 36, 40, 44, 48), ssk, pm*, k32 (36, 40, 44, 48, 52), rep from * to * once, knit to end—125 (141, 157, 173, 189, 205) sts rem. Cont in St st on body sts, work 3 rows even. **Dec row:** (RS) Knit to 2nd m, *sl m, k2tog, knit to 2 sts before next m, ssk, sl m*, knit to next m, rep from * to * once, knit to end—4 sts dec'd. Rep Dec row every 4th row 3 more times—109 (125, 141, 157, 173, 189) sts rem. Work 5 rows even, ending with a WS row. **Inc row:** (RS) Knit to 2nd m, *sl m, M1L, knit to next m, M1R, sl m*, knit to next m, rep from * to * once, knit to end—4 sts inc'd. Rep Inc row every 6th row 2 more times—121 (137, 153, 169, 185, 201) sts. Removing m on next row, work even until piece measures 13" from CO, ending with a WS row. Leave sts on needle.

SLEEVES

With dnp, CO 36 (38, 40, 42, 44, 46) sts. Pm and join in the rnd. Work in garter st (knit 1 rnd, purl 1 rnd) until piece measures 2" from CO. Cont in St st (knit every rnd), inc 1 st each side of m on next rnd, then every 14 (14, 12, 10, 8, 6)th rnd 5 (5, 6, 7, 9, 10) more times—48 (50, 54, 58, 64, 68) sts. Work even until sleeve measures 18" from CO, ending last rnd 2 (2, 3, 3, 5, 6) sts before m. Place 2 (2, 3, 3, 5, 6) sts on each side of m onto a holder for underarm—44 (46, 48, 52, 54, 56) sts rem.

YOKE

Join sleeves and body: (RS) K30 (34, 37, 41, 43, 46) right front sts, place 4 (4, 6, 6, 10, 12) sts on holder for underarm, pm, k44 (46, 48, 52, 54, 56) sleeve sts, pm, k56 (64, 70, 78, 82, 88) back sts, place 4 (4, 6, 6, 10, 12) sts on holder for underarm, pm, k44 (46, 48, 52, 54, 56) sleeve sts, pm, k27 (31, 34, 38, 40, 43) left front sts—201 (221, 237, 261, 273, 289) sts.

Note: Raglan and right and left front neck shaping occur simultaneously. Read through the foll instructions before proceeding.

Shape raglan armholes and front

necks: Work raglan dec row (see Stitch Guide) every RS row 16 (16, 16, 17, 18, 18)

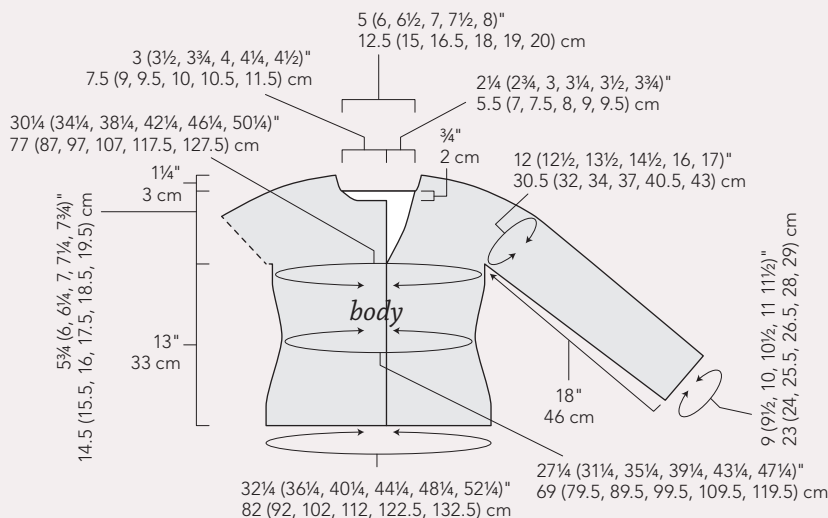



CHARLOTTE FIBER FESTIVAL

JUNE 22-JUNE 24 **2012**

www.charlottefiberfestival.com

Charlotte, North Carolina
Metrolina Trade Show Expo Center

Join us for an exciting vendor area and classes in:
Knitting, Crochet, Spinning, Felting, Dying, Weaving and more!

Vendor space still available! Apply online.

SPONSORED BY...



use code "FALLCOLORS"
for 20% off at
Creatively Dyed Yarns!
expires 11/15/2011



knitter's
magazine



Halos of Hope



times, then [work body dec row (see Stitch Guide) on next WS row, then raglan dec row on next RS row] 1 (2, 3, 4, 4, 5) times; **at the same time**, shape left front neck beg on first raglan dec row by dec 1 st at end of every RS row 7 (9, 10, 11, 12, 13) times; **at the same time**, beg right front neck shaping on Row 30 (32, 34, 38, 40, 42) as foll: (WS) Work to last 8 (10, 11, 12, 13, 14) sts, turn; place rem sts on holder for neck. Dec 1 st at beg of every RS row 2 times. When all shaping is completed—44 (48, 50, 52, 54, 56) sts rem; 2 sts each front, 10 sts each sleeve and 20 (24, 26, 28, 30, 32) sts for back. BO rem sts.

FINISHING

Collar and left front band: With RS facing, knit 8 (10, 11, 12, 13, 14) right front sts from holder, pick up and knit 1 st for every st across right front, back and down left front neck to base of V-neck, then pick up and knit about 2 sts for every 3 rows down center left front to lower edge. Pm at each raglan seam (4 m total) and pm at beg of left front neck shaping. Knit 3 rows. Work short-rows (see Glossary) for back neck and shawl collar in garter st as foll:

Short-Row 1: (RS) Knit to 4th m, wrap next st and turn.

Short-Row 2: (WS) Knit to last m, wrap next st and turn.

Short-Row 3: Knit to 3 sts before last wrapped st, wrap next st and turn.

Rep Short-Row 3 five more times. **Shape shawl collar:**

Row 1: (RS) Knit to last m, wrap next st and turn.

Row 2: (WS) Knit to end.

Row 3: *Knit to m, sl m, M1, knit to m, M1, sl m; rep from * once more, knit to 2 sts before last wrapped st, wrap next st and turn—4 sts inc'd.

Row 4: Knit to end.

Row 5: Knit to 2 sts before last wrapped st, wrap next st and turn.

Row 6: Knit to end.

Rep Rows 3–6 four more times—16 sts inc'd. Knit 4 rows. BO all sts loosely.

Weave in ends. Graft underarm seams tog, using Kitchener st (see Glossary). Block. Sew snaps on front bands, evenly spaced, and overlapping right front over left the width of left front band only.

Katya Frankel is a freelance knitwear designer living and designing in Newcastle upon Tyne, England.





WE THINK THERE'S A PATTERN HERE. AND THEN SOME.

Check out Norah Gaughan's newest collection. Using exclusively Berroco® yarns, she writes the books we know you'll love!

(Order yours today!)

jimmy beans wool 

YOUR LOCAL YARN STORE... ONLINE!

WWW.JIMMYBEANSWOOL.COM (877) JBW - KNIT (529-5648)

VISIT OUR SHOP IN RENO, NV FOLLOW US   

*I'm a Travelin' Man
I've made a lot of stops
all over the world.
And in every port
I own the heart
Of at least one
lovely girl.
- Ricky Nelson*

Traveling Man Sweater
by Anne Berk

www.bluemoonfiberarts.com

Photo: Christopher Hall



HONEYCOMB JACKET

Laura Grutzeck

Finished Size 34 (36, 40, 44, 48, 52)" bust circumference. Jacket shown measures 36".

Yarn Jo Sharp Silkroad DK Tweed (85% wool, 10% silk, 5% cashmere; 147 yd [135 m]/1¼ oz [50 g]): #414 autumn, 12 (13, 14, 15, 16, 17) balls.

Needles Size 6 (4 mm): 24" circular (cir). Adjust needle size if necessary to obtain the correct gauge.

Notions Markers (m); eight 1" buttons.

Gauge 24 sts and 44 rows = 4" in honeycomb sl st patt.

NOTES

- A circular needle is used to accommodate the large number of sts; work back and forth in rows on all pieces.
- Slip stitches purlwise unless indicated otherwise.

Stitch Guide

Honeycomb Slip-Stitch Pattern: (odd number of sts)

Rows 1 and 3: (RS) Knit.

Row 2: *K1, sl 1 with yarn in back (wyb); rep from * to last st, k1.

Row 4: K2, *sl 1 wyb, k1; rep from * to last st, k1.

Rep Rows 1–4 for patt.

BACK

CO 136 (144, 160, 176, 192, 208) sts.

Double-knit hem:

Row 1: (WS) *K1, sl 1 with yarn in front (wyf); rep from * to last 2 sts, k2. Rep last row every row until piece measures 2" from CO, ending with a WS row.

Dec row: (RS) K1, *k2tog; rep from * to last st, k1—69 (73, 81, 89, 97, 105) sts rem. **Inc row:** (WS) *K1, k1f&b; rep from * to last st, k1—103 (109, 121, 133, 145, 157) sts.

Body: Set-up row: (RS) Sl 1 kwise wyb (selvage st), work honeycomb sl st patt (see Stitch Guide) to last st, p1

st). Cont in patt as established, slipping first st and purling last st of every row for selvage sts, until piece measures 4" from CO, ending with a WS row. **Shape waist: Dec row:** (RS) Sl 1 kwise wyb, ssk, work in patt to last 3 sts, k2tog, p1—2 sts dec'd. Rep Dec row every 12th row 5 more times—91 (97, 109, 121, 133, 145) sts rem. Work even until piece measures 12" from CO, ending with a WS row. **Inc row:** (RS) Sl 1 kwise wyb, k1f&b, work in patt to last 2 sts, k1f&b, p1—2 sts inc'd. Rep Inc row every 6th row 5 more times—103 (109, 121, 133, 145, 157) sts. Work even until piece measures 16" from CO, ending with a WS row. **Shape armholes:** BO 6 (6, 8, 8, 10, 10) sts at beg of next 2 rows, then 0 (0, 0, 4, 4, 6) sts at beg of next 2 rows—91 (97, 105, 109, 117, 125) sts rem.

Dec row: (RS) Sl 1 kwise wyb, ssk, work in patt to last 3 sts, k2tog, p1—2 sts dec'd. Rep Dec row every other row 6 (7, 9, 10, 11, 12) more times—77 (81, 85, 87, 93, 99) sts rem. Work even until armholes measure 7½ (8, 8½, 9, 9½, 10)", ending with a WS row. **Shape neck and shoulders:** (RS) Work 21 (23, 25, 26, 29, 32) sts, join new yarn and BO center 35 sts, work to end—21 (23, 25, 26, 29, 32) sts rem each side. BO 4 (5, 5, 6, 6, 7) sts at beg of next 6 rows, then 6 (5, 7, 5, 8, 8) sts at beg of next 2 rows, and **at the same time**, dec 1 st at each neck edge every RS row 3 times.

LEFT FRONT

CO 68 (72, 80, 88, 96, 104) sts.

Double-knit hem:

Row 1: (WS) *Sl 1 wyf, k1; rep from * to end. **Row 2:** K2, *sl 1 wyf, k1; rep from * to end. Rep last 2 rows until piece measures 2" from CO, ending with a WS row. **Dec row and front band:** (RS) K2, *k2tog; rep from * to last 16 sts, pm, [sl 1 wyf, k1] 8 times—43 (45, 49, 53, 57, 61) sts rem.

Inc row: (WS) Work double-knit patt to m, sl m, k1 (2, 2, 0, 2, 2), [k1f&b, k1] 12 (12, 14, 18, 18, 20) times, k1f&b, k1 (2, 2, 0, 2, 2)—56 (58, 64, 72, 76, 82) sts. **Body: Set-up row:** (RS) Sl 1 kwise, work honeycomb sl st patt to m, work double-knit patt to end. **Next row:** Work double-knit patt to m, work honeycomb sl st patt to last st, p1. Cont in patt as established until piece measures 4" from CO, ending with a WS row.

Shape waist: Dec row: (RS) Sl 1 kwise, ssk, work to end—1 st dec'd. Rep Dec row every 12th row 5 more times—50 (52, 58, 66, 70, 76) sts rem. Work even until piece measures 12" from CO, ending with a WS row. **Inc row:** (RS) Sl 1 kwise, k1f&b, work to end—1 st inc'd. Rep Inc row every 6th row 5 more times—56 (58, 64, 72, 76, 82) sts. Work even until piece measures 16" from CO, ending with a WS row. **Shape armhole:** At armhole edge (beg of RS rows) BO 6 (6, 8, 8, 10, 10) sts once, then 0 (0, 0, 4, 4, 6) sts once—50 (52, 56, 60, 62, 66) sts rem. Work 1 row even. **Dec row:**



Picture-perfect Hats



Rejoice in knitted hats no matter what day it is! Discover the best in designer patterns with 25 clever and comfortable variations of the best head-turning, want-to-wear accessory.



Weekend Hats
25 Knitted Caps, Berets, Cloches, and More
 Cecily Glowik MacDonald,
 Melissa LaBarre
 128 pages, 8½ × 9, \$22.95
 ISBN: 978-1-59668-438-6

INTERWEAVE
 interweavestore.com



DEBBIE MACOMBER

BLOSSOM STREET™ COLLECTION

Garter Aran Button Shawl
Cashmere Fleur de Lys

Blossom Street Collection Book 4
 A Collection of 10 New Designs in Debbie Macomber's Yarns



UNIVERSAL YARN

www.universalyarn.com



Scan this QR code with your smartphone. The code will take you to the Universal Yarn website where you can find information about the yarn and pattern book.

"Debbie Macomber" & "Blossom Street" are trademarks of Debbie Macomber, Inc.
www.DebbieMacomber.com

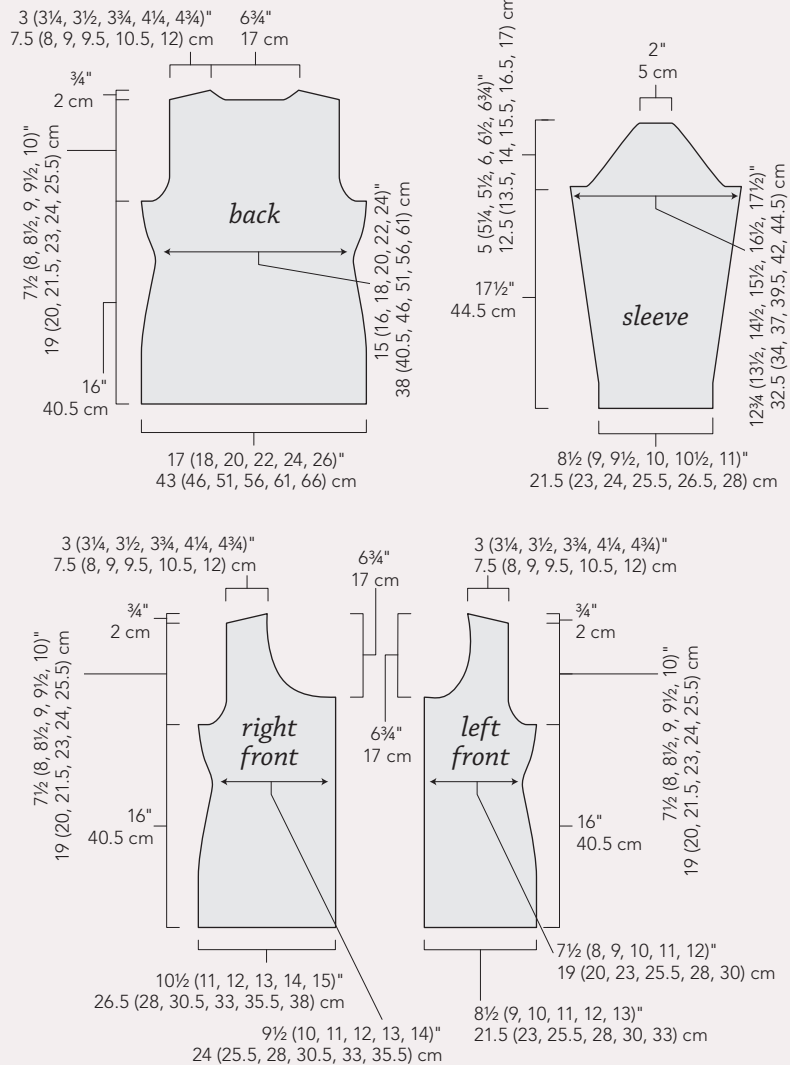

(RS) Sl 1 kwise, ssk, work to end—1 st dec'd. Rep Dec row every RS row 6 (7, 9, 10, 11, 12) more times—43 (44, 46, 49, 50, 53) sts rem. Work even, if necessary, until armhole measures 1½ (2, 2½, 3, 3½, 4)", ending with a WS row. **Shape neck:** (RS) Work in patt to m, [k2tog] 8 times—35 (36, 38, 41, 42, 45) sts rem; 8 band sts and 27 (28, 30, 33, 34, 37) body sts. **Next row:** (WS) BO 8 sts, work to end—27 (28, 30, 33, 34, 37) sts rem. **Dec row:** (RS) Work to last 3 sts, k2tog, p1—1 st dec'd. Rep Dec row every RS row 3 (2, 2, 4, 2, 2) more times, then every 6th row 5 times. **At the same time,** when armhole measures 7½ (8, 8½, 9, 9½, 10)", end with a WS row and shape shoulder as foll: At beg of RS rows, BO 4 (5, 5, 6, 6, 7) sts 3 times, then 6 (5, 7, 5, 8, 8) sts once. Mark placement for 6 buttons along button band, the first 1" from bottom edge and the last ½" from neck edge, and rem buttons evenly spaced between.

RIGHT FRONT

CO 84 (88, 96, 104, 112, 120) sts.

Double-knit hem:

Row 1: (WS) K2, *sl 1 wyf, k1; rep from * to end.

Row 2: *sl 1 wyf, k1; rep from * to end. Rep last 2 rows until piece measures 1" from CO, ending with a WS row.

Buttonhole row: (RS) Work 6 sts in patt, BO 4 sts for buttonhole, work in patt to end. **Next row:** (WS) Work in patt to BO sts, then using the backward-loop method, CO 4 sts, work to end. Rep buttonhole row 5 more times, working buttonholes to correspond to m on left-front band, and **at the same time,** work in double-knit patt until piece measures 2" from CO, ending with a WS row. **Dec row and front band:** (RS) Work 16 sts in double-knit patt for front band, pm, *k2tog; rep from * to last 2 sts, k2—51 (53, 57, 61, 65, 69) sts rem. **Inc row:** (WS) K2, [k1f&b, k1] 15 (17, 19, 21,

23, 25) times, k3 (1, 1, 1, 1, 1), sl m, work in double-knit patt to end—66 (70, 76, 82, 88, 94) sts. **Body: Set-up row:** (RS) Work in patt to m, sl m, work honeycomb sl st patt to last st, p1. **Next row:** Sl 1 kwise, work honeycomb sl st patt to m, sl m, work in patt to end. Cont in patt as established until piece measures 4" from CO, ending with a WS row. **Shape waist: Dec row:** (RS) Work to last 3 sts, k2tog, p1—1 st dec'd. Rep Dec row every 12th row 5 more times—60 (64, 70, 76, 82, 88) sts rem. Work even until piece measures 12" from CO, ending with a WS row. **Inc row:** (RS) Work to last 2 sts, k1f&b, p1—1 st inc'd. Rep Inc row every 6th row 5 more times—66 (70, 76, 82, 88, 94) sts. Work even until piece measures 16" from CO, ending with a RS row. **Shape armhole:** At beg of WS rows, BO 6 (6, 8, 8, 10, 10) sts once, then 0 (0, 0, 4, 4, 6) sts once—60 (64, 68, 70, 74, 78) sts rem. **Dec row:** (RS)

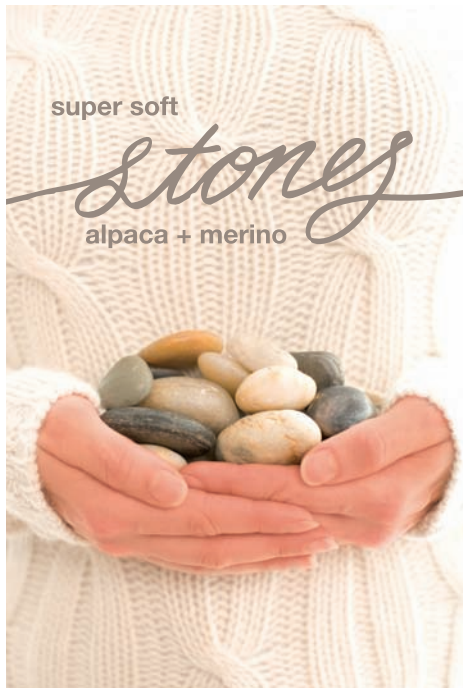

super soft

stones
alpaca + merino



super soft

fruit
merino



super soft

eggs
merino

www.peartreeyarn.com

 peartreeyarn
australia



Stitch a Broad Spectrum!



www.martingale-pub.com | 1-800-426-3126

Buy today wherever knitting books are sold!

Martingale
& COMPANY

America's Best-Loved Knitting Books®

Work to last 3 sts, k2tog, p1—1 st dec'd. Rep Dec row every RS row 6 (7, 9, 10, 11, 12) more times—53 (56, 58, 59, 62, 65) sts rem. Work even, if necessary, until armhole measures 1½ (2, 2½, 3, 3½, 4)", ending with a WS row. **Shape neck: Next row:** (RS) [K2tog] 2 times, pass first st over second st, *k2tog, pass first st over; rep from * to m (1 st rem on right needle), remove m, k1, pass first st over, work in patt to end—37 (40, 42, 43, 46, 49) sts rem. Work 1 row even. **Dec row:** (RS) Sl 1 kwise, ssk, work to end—1 st dec'd. Rep Dec row every RS row 10 (11, 11, 11, 11, 11) more times, then every 4th row 8 times. **At the same time,** when armhole measures 7½ (8, 8½, 9, 9½, 10)", end with a RS row and shape shoulder as foll: At beg of WS rows, BO 4 (5, 5, 6, 6, 7) sts 3 times, then 6 (5, 7, 5, 8, 8) sts once.

SLEEVES

CO 68 (72, 76, 80, 84, 88) sts.

Double-knit cuff:

Row 1: (WS) *K1, sl 1 wyf; rep from * to last 2 sts, k2. Rep last row every row until piece measures 2" from CO, ending with a WS row. **Dec row:** (RS) K1, *k2tog; rep from * to last st, k1—35 (37, 39, 41, 43, 45)

sts rem. **Inc row:** K2 (1, 2, 3, 2, 3), [k1f&b, k1] 16 (18, 18, 18, 20, 20) times, k1 (0, 1, 2, 1, 2)—51 (55, 57, 59, 63, 65) sts. **Set-up row:** (RS) Sl 1 kwise, work honeycomb sl st patt to last st, p1. Cont in patt as established, work 11 (11, 9, 7, 7, 7) rows even, ending with a WS row. **Inc row:** (RS) Sl 1 kwise, k1f&b, work to last 2 sts, k1f&b, p1—2 sts inc'd. Rep Inc row every 8th row 0 (0, 0, 4, 9, 19) times, every 10th row 0 (0, 9, 12, 8, 0) times, every 12th row 10 (10, 5, 0, 0, 0) times, every 14th row 2 (2, 0, 0, 0, 0) times—77 (81, 87, 93, 99, 105) sts. Work even until piece measures 17½" from CO, ending with a WS row. **Shape cap:** BO 6 (6, 8, 8, 10, 10) sts at beg of next 2 rows, 0 (0, 0, 4, 4, 6) sts at beg of next 2 rows—65 (69, 71, 69, 71, 73) sts rem. **Dec row:** (RS) Sl 1 kwise, ssk, work to last 3 sts, k2tog, p1—2 sts dec'd. Rep Dec row every RS row 6 (7, 9, 10, 10, 12) more times—51 (53, 51, 47, 49, 47) sts rem. Work 3 (3, 3, 9, 11, 11) rows even. Rep Dec row every RS row 19 (20, 19, 17, 18, 17) more times. BO rem 13 sts.

FINISHING

Sew shoulder seams. **Collar:** With RS

facing, pick up and knit 8 sts along top of right-front button band, 44 sts along right-front neck, 24 sts along back neck, 44 sts along left-front neck, and 8 sts along top of left-front button band—128 sts. **Next row:** (WS) *K1f&b; rep from * to end—256 sts. **Next row:** *Sl 1 wyf, k1; rep from * to end. Rep last row every row until collar measures 2¾", ending with a RS row. **Buttonhole row:** (WS) Work to last 10 sts, BO 4 sts, work to end. **Next row:** Work in patt, CO 4 sts over BO sts. Rep buttonhole when collar measures 5½". Work even until collar measures 6", ending with a WS row. **BO row:** (RS) [K2tog] 2 times, pass first st over second st, *k2tog, pass first st over; rep from * to end. Block pieces to measurements. Sew in sleeves. Sew sleeve and side seams. Sew on buttons opposite buttonholes.

Laura Grutzeck lives in Philadelphia, Pennsylvania, with her husband and dogs. She is a frequent contributor to *Interweave Knits* and a coauthor of *Knit So Fine: Designs with Skinny Yarn* (Interweave, 2008).



Enter the world of your favorite designers, *instantly!*

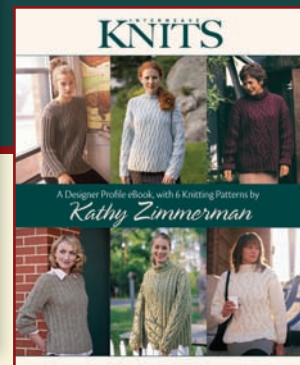
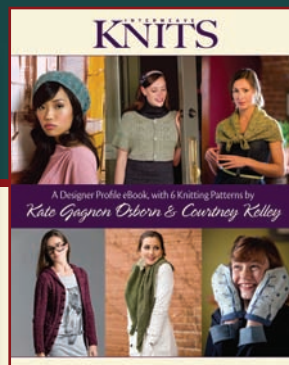
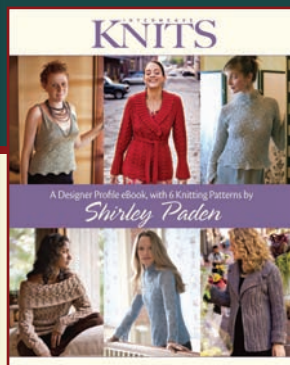
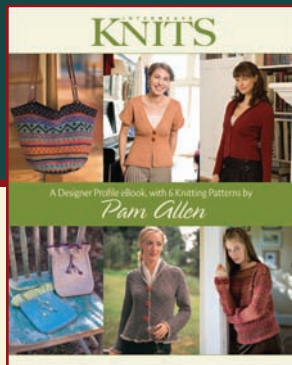

Save over **30%**

on Patterns from top knitwear designers
with downloadable Designer Profile eBooks

Visit the  **knittingdailyshop** online and instantly download your favorite eBook today.

 **RED HEART**
BOUTIQUE

Changes



Captivating Cowl - LW2462

This and other free patterns available at
www.redheart.com

11-0044
© 2011 Coats & Clark



SHIBUI TEXTURE

JUNE 2011

BANDON BY SARA MORRIS
www.shibuiknits.com

KATE GAGNON OSBORN

Flanders Bay Pullover



A bonus pattern from *Vintage Modern Knits* by Courtney Kelley and Kate Gagnon Osborn, Interweave, 2010.

Named after a bay off the rocky coast of Maine, where having a sweater on hand year-round is an absolute must, and inspired by both French striped navy shirts and a love of all things New England, this sweater incorporates stripes and quirky Fair Isle anchors into the same garment. The body of this comfy, casual pullover is knitted in the round to the armholes, then separated for the back and front. The set-in sleeves are knitted flat to the armholes and finished with full-fashioned caps. A special tubular cast-on creates a professional, finished look to the ribbed edges, and modern contrasting colors add to the overall nautical look.



DIVIDE FOR FRONT AND BACK

Removing markers as you come to them, BO 8 (8, 8, 10, 10, 10) sts, knit to 4 (4, 4, 5, 5, 5) sts before next m, BO 8 (8, 8, 10, 10, 10) sts, knit to end—60 (67, 75, 80, 88, 95) sts rem for front; 59 (67, 74, 80, 87, 95) sts rem for back.

BACK

Maintaining stripe sequence as established, work 59 (67, 74, 80, 87, 95) back sts in rows as foll.

Shape Armholes

Sizes 42¼ (46, 49½)" (107.5 [117, 125.5] cm) only

BO 2 (3, 4) sts at beg of next 2 rows—76 (81, 87) sts rem.

All Sizes

With WS facing, purl 1 row.

Dec row: (RS) K2, k2tog, knit to last 4 sts, ssk—2 sts dec'd.

Rep the last 2 rows 4 (4, 5, 6, 7, 8) more times—49 (57, 62, 62, 65, 69) sts rem.

Cont in St st until armholes measure 6 (6½, 7, 7½, 8, 8½)" (15 [16.5, 18, 19, 20.5, 21.5] cm), ending with a RS row.

Shape Left Neck

Row 1: (WS) P14 (16, 17, 18, 19, 20), turn work, leaving 35 (41, 45, 44, 46, 49) sts on needle to work later for right shoulder and back neck.

Row 2: (RS) BO 5 sts, knit to end—9 (11, 12, 13, 14, 15) sts rem.

Work 3 rows even in St st without shaping.

Place these 9 (11, 12, 13, 14, 15) sts on a holder.

Shape Right Neck

With RS facing, join yarn to 35 (41, 45, 44, 46, 49) unworked sts.

Row 1: (RS) K14 (16, 17, 18, 19, 20), turn work, place rem 21 (25, 28, 26, 27, 29) sts on a holder for back neck.

Next row: (WS) BO 5 sts, purl to end—9 (11, 12, 13, 14, 15) sts rem.

Work 3 rows even in St st. Place these 9 (11, 12, 13, 14, 15) sts on a holder.

FRONT

With WS facing, join yarn to 60 (67, 75, 80, 88, 95) sts front sts. Maintaining stripe sequence as established, work as foll.

Shape Armholes

Sizes 42¼ (46, 49½)" (107.5 [117, 125.5] cm) only

BO 2 (3, 4) sts at beg of next 2 rows—76 (82, 87) sts rem.

All Sizes

With WS facing, purl 1 row.

Dec row: (RS) K2, k2tog, knit to last 4 sts, ssk, k2—58 (65, 73, 74, 80, 85) sts rem.

Next row: (WS) Purl.

Next row: (RS) K2, k2tog, k12 (15, 17, 18, 20, 23), k2tog, k1, place next 39 (43, 49, 49, 53, 55) sts on holder for neck and right front—17 (20, 22, 23, 25, 28) sts rem for left front.

Left Front

With WS facing, purl 1 row.

Next row: (RS) K2, k2tog, knit to last 3 sts, k2tog, k1—2 sts dec'd.

Dec 1 st at armhole edge in this manner every RS row 2 (2, 3, 4, 5, 6) more times and **at the same time** dec 1 st at neck edge in this manner every RS row 2 (2, 3, 3, 3, 4) more times, then every 4th row 2 (3, 2, 1, 1, 1) time(s)—9 (11, 12, 13, 14, 15) sts rem when all armhole and neck shaping is complete. Cont even until armhole measures same length as back, ending with a WS row. Place sts on a holder.

Right Front

Place 20 (21, 25, 24, 26, 25) center sts on a

TUBULAR CAST-ON FOR 2×2 RIB

The tubular cast-on creates an edge that emulates one produced in a machine-knitted garment. The end result is a clean, professional look with a lot of stretch for ease of wear.

To begin this cast-on for the Flanders Bay Pullover, use a contrasting smooth waste yarn of comparable gauge, larger needles, and CC, and use the crochet-chain method (see Glossary) to provisionally CO one-half of the desired number of stitches. (For example, for the smallest size in this pattern, which requires 144 stitches, provisionally cast on 72 stitches.) Place marker and join for working in the round, being careful not to twist the stitches, and knit 3 rounds.

On the next round, fold the cast-on edge to the wrong side and pick up the loops from the provisionally cast-on stitches between the live stitches on the needle as follows:

Step 1. K2, working from left to right, use the left needle to pick up the loop from the second provisionally cast-on stitch (Figure 1).

Step 2. Pick up the loop from the first provisionally cast-on stitch (Figure 2).

Step 3. Purl these 2 new sts (Figure 3).

Repeat these 3 steps to the end of the round—the stitch count will be doubled. Remove the waste yarn from the provisional cast-on.

To work this cast-on in rows, use the crochet-chain method to cast on one-half the desired number of stitches, then beginning and ending with a purl (wrong side) row, work 3 rows in stockinette stitch. With the right side facing, pick up the loops from the provisionally cast-on stitches as described above, ending by knitting the last cast-on stitch, then knitting the last picked-up stitch, so that the ribbing begins and ends with k2.

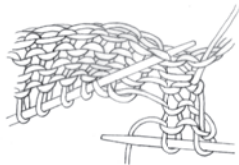

Figure 1

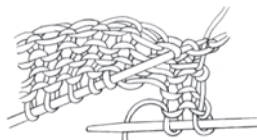

Figure 2



Figure 3

holder. With RS facing, rejoin yarn to rem 19 (22, 24, 25, 27, 30) sts.

Next row: (RS) K1, ssk, knit to last 4 sts, ssk, k2—2 sts dec'd.

Purl 1 WS row. Dec 1 st at armhole edge in this manner every RS row 3 (3, 4, 5, 6, 7) more times and **at the same time** dec 1 st at neck edge in this manner every RS row 3 (3, 4, 4, 4, 5) more times, then every 4th row 2 (3, 2, 1, 1, 1) time(s)—9 (11, 12, 13, 14, 15) sts rem when all armhole and neck shaping is complete. Cont even until armhole measures same length as back, ending with a WS row. Place sts on a holder.

SLEEVES

With CC and larger needle, use the Tubular

Cast-On for 2×2 Rib Worked in Rows to CO 46 (46, 50, 50, 54, 54) sts. Change to smaller needle. Work in k2, p2 rib as established until piece measures 2" (5 cm) from CO, ending with a WS row. Change to larger needle and stripe in stripe sequence and **at the same time** shape sleeve as foll:

Dec row: K1, *k9 (9, 10, 10, 11, 11), k2tog; rep from * to last st, k1—42 (42, 46, 46, 50, 50) sts rem.

Beg with a WS row, work 15 (15, 15, 15, 15, 7) rows even in St st.

Inc row: (RS) K2, M1L, knit to last 2 sts, M1R, k2—2 sts inc'd.

Work 7 rows even in St st. Rep the last 8 rows 7 (7, 7, 9, 10, 11) more times—58 (58, 62, 66, 72, 74) sts. Cont even in St st until

piece measures 19" (48.5 cm) from CO, or desired length to underarm, ending with a WS row.

Shape Cap

BO 5 (5, 5, 6, 6, 6) sts at beg of next 2 rows, then BO 0 (0, 0, 0, 2, 4) sts at beg of foll 0 (0, 0, 0, 2, 2) rows—48 (48, 52, 54, 56, 54) sts rem. Dec 1 st each end of needle every row 3 times—42 (42, 46, 48, 50, 48) sts rem. Purl 1 WS row.

Dec row: (RS) K2, k2tog, knit to last 4 sts, ssk, k2—2 sts dec'd.

Work 3 rows even in St st. Rep the last 4 rows 2 (2, 2, 3, 3, 3) more times—36 (36, 40, 40, 42, 40) sts rem. Rep Dec row, then purl 1 (WS) row. Rep the last 2 rows 10 (10, 11, 11, 12, 12) more times—14 (14, 16, 16, 16, 14) sts rem. Dec 1 st each end of needle every row 2 times—10 (10, 12, 12, 12, 10) sts rem. BO all sts.

FINISHING

Block pieces to measurements. Place 9 (11, 12, 13, 14, 15) right front sts on one needle and corresponding 9 (11, 12, 13, 14, 15) right back sts on another needle. Hold the needles parallel with RS facing tog and use the three-needle method (see Glossary) to BO the shoulder sts tog. Rep for left shoulder. With yarn threaded on a tapestry needle, sew sleeve caps into armholes, matching centers of caps to shoulder seams and stripes along armhole edges. Sew sleeve seams. Weave in loose ends.

Neck Ribbing

With RS facing, smaller cir needle, and beg at back neck, k21 (25, 28, 26, 27, 29) held back neck sts and **at the same time** inc 1 (0, 1, 0, 1, 0) st, then pick up and knit 9 sts to shoulder seam, 31 (33, 35, 37, 39, 41) sts along left front edge, work 20 (21, 25, 24, 26, 25) held front neck sts as k2tog, k16 (17, 21, 20, 22, 21), k2tog, then pick up and knit 31 (33, 35, 37, 39, 41) sts along right front neck edge to shoulder, and 9 sts along back neck edge—120 (128, 140, 140, 148, 152) sts total. Pm and join for working in rnds. Work in k2, p2 rib for 7 rnds. BO all sts in patt. ■



all in a
GOLDEN AFTERNOON
IN WHICH LACE MOTIFS GO UNEXPECTED.



HEATHER ZOPPETTI borrows doily construction techniques to pattern the intricate-looking flower motif that adorns the back of the **DAHLIA CARDIGAN**. Sleeves put in like afterthought heels grow out of a simple rectangle for an easy layering piece with serious drape. A lightweight alpaca and cotton blend yarn gives the long fronts swingy movement. **PAGE 82. YARN** Manos del Uruguay Serena, distributed by Fairmount Fibers



all in a
GOLDEN AFTERNOON





Inspired by the lace patterns of Herbert Niebling, **REBECCA BLAIR** uses a simple-to-work but wonderfully delicate hexagonal mesh pattern to give the **HEX MESH STOCKINGS** sheer, clinging stretch. Sweet lace bands and crocheted edge loops finish the edges—make them tall and wear them with garters or end them just below the knee. **PAGE 86.**
YARN Malabrigo Lace





MAREIKE SATTLER explores the knitting traditions of Germany in the **FERN LACE STOLE**, combining structural elements with openwork for a fabric with texture as well as lacy patterning. Forced into long, undulating lines by a rippling lace pattern, picot-edged welts lend strong visual contrast and structured drape to a light-as-air stole. **PAGE 92.** YARN Filatura di Crosa Superior, distributed by Tahki Stacy Charles

The **WHEELED LACE SHAWL** takes a traditional lace motif—concentric rings of eyelets that form a delicate wheel—and extrapolates it into an unusual knitted edging. **KRISTIN OMDAHL** knits the edging medallions one at a time, joining them to the body of the shawl as they are worked, to create a lightweight edging with fluttering movement. **PAGE 96.** YARN Shibui Knits Silk Cloud

all in a
GOLDEN AFTERNOON

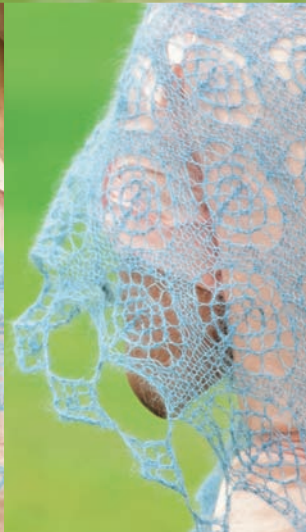



DAHLIA CARDIGAN

Heather Zoppetti

Finished Size 30 (35½, 40½, 45½, 50)" bust circumference, with fronts overlapped about 4". Cardigan shown measures 35½".

Yarn Manos del Uruguay Serena (60% baby alpaca, 40% pima cotton; 170 yd [155 m]/1¼ oz [50 g]): #2150 fig. 5 (6, 7, 8, 9) skeins. Yarn distributed by Fairmount Fibers.

Needles Size 5 (3.75 mm): 32" circular (cir) and set of double-pointed (dnp). Adjust needle size if necessary to obtain the correct gauge.

Notions Markers (m); waste yarn; size E/4 (3.5 mm) crochet hook for provisional CO; tapestry needle.

Gauge 24 sts and 32 rows = 4" in St st; lace panel measures about 13" square, after blocking.

NOTES

- The square back lace panel is worked first in the round from the center out. Stitches are bound off along the upper and lower edges of the panel, leaving live stitches on holders along the remaining two sides.
- The upper and lower back each begin with a provisional cast-on at center back and are worked separately from the middle of the back outward. For the back sides, the upper and lower back stitches are joined to the live stitches from one side of the lace panel, and the joined stitches are worked in one piece out to the side of the body (see Back Diagram). During finishing, the upper and lower back sections are seamed to the bound-off top and bottom edges of the lace panel.
- The afterthought armhole positions are marked by working a set of stitches at each side using waste yarn. Both fronts are worked from the side of the body inward and finished with a seed-

stitch border. The sleeve stitches are picked up around the armhole openings and worked in the round down to the cuffs. The left sleeve is not shown on the schematic.

- On right-side rows, slip stitches knitwise with yarn in back; on wrong-side rows, slip stitches purlwise with yarn in front.

LACE PANEL

Using the crochet provisional method (see Glossary), CO 4 sts. **Next row:** [K1f&b] 4 times—8 sts. Divide sts evenly over 4 dnp. Place marker (pm), and join in the rnd. Work Rnds 1–26 of Chart A, working chart patt 4 times around (once on each needle)—136 sts total; 34 sts on each needle. Work Rnds 1–30 of Chart B, changing to cir needle when necessary, and pm after each patt rep—280 sts total; 4 patt reps of 70 sts each.

Next rnd: K70 for right side, BO 70 sts for upper edge, k70 for left side, BO 70 sts for bottom edge. Place 70 sts for each side on separate waste yarn holders.

RIGHT BACK AND SIDE

Upper back: With cir needle and using the crochet provisional method, CO 44 (44, 50, 56, 62) sts.

Row 1: (RS) Sl 1, k23 (23, 26, 29, 32), pm, purl to last 5 sts, [k1, p1] 2 times, k1.

Row 2: (WS) Sl 1, [p1, k1] 2 times, p1, knit to m, sl m, purl to end. Rep last 2 rows 25 more times, ending with a WS row—piece measures 6½" from CO. Place sts on waste yarn, leaving m in position.

Lower back: With cir needle and using the crochet provisional method, CO 32 (32, 35, 38, 41) sts.

Row 1: (RS) Sl 1, [k1, p1] 2 times, knit to end.

Row 2: (WS) Sl 1, purl to last 6 sts, [k1, p1] 3 times.

Rep last 2 rows 25 more times, ending with a WS row—piece measures 6½" from CO. Leave sts on needle.

Right side: Return 70 held right side lace panel sts and 44 (44, 50, 56, 62) held upper back sts (including m) to cir needle with RS facing so that pieces will be worked in this order on next RS row: lower back, lace panel, upper back—146 (146, 155, 164, 173) sts total.

Row 1: (RS) Sl 1, [k1, p1] 2 times, k26 (26, 29, 32, 35), ssk (last lower-back st tog with first lace panel st), k68 center lace panel sts, k2tog (last lace panel st tog with first upper-back st), knit to m, sl m, purl to last 5 sts, [k1, p1] 2 times, k1—144 (144, 153, 162, 171) sts rem.

Row 2: (WS) Sl 1, [p1, k1] 2 times, p1, knit to m, sl m, purl to last 6 sts, [k1, p1] 3 times.

Row 3: Sl 1, [k1, p1] 2 times, knit to m, sl m, purl to last 5 sts, [k1, p1] 2 times, k1. Rep last 2 rows 0 (2, 4, 6, 8) more times, then work Row 2 once more—4 (8, 12, 16, 20) side rows completed; piece measures ½ (1, 1½, 2, 2½)" from end of lace panel, and 7 (7½, 8, 8½, 9)" from provisional CO of upper and lower back.

Mark right armhole: (RS) Sl 1, [k1, p1] 2 times, k60 (57, 57, 56, 53), knit next 36 (39, 42, 46, 52) sts using waste yarn, then return these sts to left needle and knit across them again using main yarn, knit to m, purl to last 5 sts, [k1, p1] 2 times, k1.

RIGHT FRONT

Rep Rows 2 and 3 of right side 36 (45, 53,

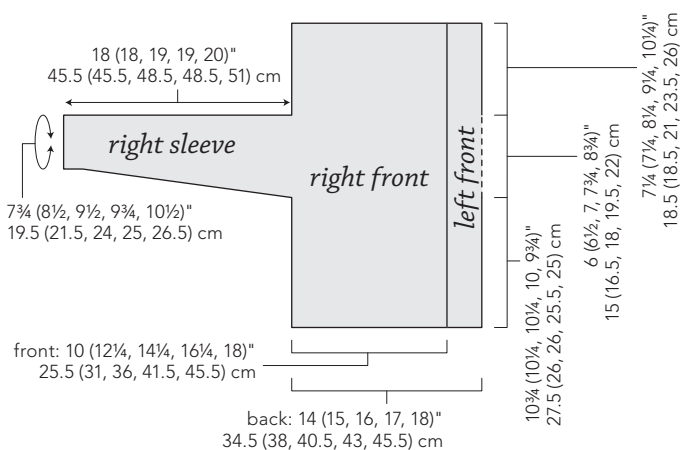

61, 68) times—front measures 9 (11¼, 13¾, 15¾, 17)" from afterthought armhole. Work seed st front border as foll:

Next row: (WS) Sl 1, *p1, k1; rep from * to last 1 (1, 2, 1, 2) st(s), p1 (p1, p2tog, p1, p2tog)—144 (144, 152, 162, 170) sts.

Next row: (RS) Sl 1, *k1, p1; rep from * to last st, k1.

Rep last row until seed st border measures 1"—front measures 10 (12¼, 14¼, 16¼, 18)" from afterthought armhole. BO loosely in patt.

LEFT BACK AND SIDE

Lower back: Carefully unzip provisional CO at start of right lower back, and place 31 (31, 34, 37, 40) live sts on cir needle.

Join main yarn with WS facing.

Set-up row: (WS) Sl 1, [k1, p1] 2 times, k1, purl to last st, M1, p1—32 (32, 35, 38, 41) sts.

Row 1: (RS) Sl 1, knit to last 5 sts, [p1, k1] 2 times, p1.

Row 2: Sl 1, [k1, p1] 2 times, k1, purl to end.

Rep last 2 rows 25 more times, ending with a WS row—piece measures 6½" from CO. Place sts on waste yarn.

Upper back: Carefully unzip provisional CO at start of right upper back, and place 43 (43, 49, 55, 61) live sts on cir needle.

Join main yarn with WS facing.

Set-up row: (WS) Sl 1, M1, p22 (22, 25, 28, 31) pm, knit to last 6 sts, [p1, k1] 3 times—44 (44, 50, 56, 62) sts.

Row 1: (RS) Sl 1, [p1, k1] 2 times, purl to m, sl m, knit to end.

Row 2: (WS) Sl 1, purl to m, sl m, knit to last 6 sts, [p1, k1] 3 times.

Rep last 2 rows 25 more times, slipping m as you come to it, and ending with a WS row—piece measures 6½" from CO. Leave sts on needle.

Left side: Return 70 held left-side lace panel sts and 32 (32, 35, 38, 41) held lower back sts to cir needle with RS facing so that the pieces will be worked in this order on the next RS row: upper back, lace panel, lower back—146 (146, 155, 164, 173) sts total.

Row 1: (RS) Sl 1, [p1, k1] 2 times, purl to m, sl m, k23 (23, 26, 29, 32), ssk (last upper-back st tog with first lace panel st), k68 center lace panel sts, k2tog (last lace panel st tog with first lower-back st), knit to last 5 sts [p1, k1] 2 times, p1—144 (144, 153, 162, 171) sts total.

Row 2: (WS) Sl 1, [k1, p1] 2 times, k1, purl to m, sl m, knit to last 6 sts, [p1, k1] 3 times.

Row 3: Sl 1, [p1, k1] 2 times, purl to m, sl m, knit to last 5 sts, [p1, k1] 2 times, p1. Rep last 2 rows 0 (2, 4, 6, 8) more times, then work Row 2 once more—4 (8, 12, 16, 20) side rows completed; piece measures ½ (1, 1½, 2, 2½)" from end of lace panel, and 7 (7½, 8, 8½, 9)" from provisional CO of upper and lower back.

Mark left armhole: (RS) Sl 1, [p1, k1] 2 times, purl to m, sl m, k23 (23, 26, 29, 32), knit next 36 (39, 42, 46, 52) sts using waste yarn, then return these sts to left needle and knit across them again using main yarn, knit to last 5 sts, [p1, k1] 2 times, p1.

LEFT FRONT

Rep Rows 2 and 3 of left side 36 (45, 53, 61, 68) times—front measures 9 (11¼, 13¾, 15¾, 17)" from afterthought armhole. Work seed st front border as foll:

Next row: (WS) Sl 1, *k1, p1; rep from * to last 1 (1, 2, 1, 2) st(s), k1 (k1, k2tog, k1, k2tog)—144 (144, 152, 162, 170) sts.

Next row: (RS) Sl 1, *p1, k1; rep from * to last st, p1.

Rep last row until seed st border measures 1"—front measures 10 (12¼, 14¼, 16¼, 18)" from afterthought armhole. BO loosely in patt.

SLEEVES

Starting at base of underarm, carefully remove waste yarn from afterthought armhole, and place live sts on dpns—71 (77, 83, 91, 103) sts total; 36 (39, 42, 46, 52) sts on side of armhole opening closer to lace panel, and 35 (38, 41, 45, 51) sts on other side. Arrange sts as evenly as possible on dpn, and join yarn with RS facing at base of armhole.

Next rnd: Knit to top of armhole, pick up and knit 1 st between two sets of armhole sts, knit to bottom of armhole, pick up and knit 1 st between two sets of armhole sts—73 (79, 85, 93, 105) sts. Pm and join in the rnd. Work in St st (knit every rnd) until sleeve measures 2½ (2½, 2½, 2¾, 2)" from body.

Dec rnd: K1, k2tog, knit to last 2 sts, ssk—2 sts dec'd. Rep Dec rnd every 8 (8, 8, 7, 6)th rnd 10 (10, 11, 13, 17) more times—51 (57, 61, 65, 69) sts rem; sleeve measures 12¾ (12¾, 13¾, 13¾, 14¾)"

Chart A

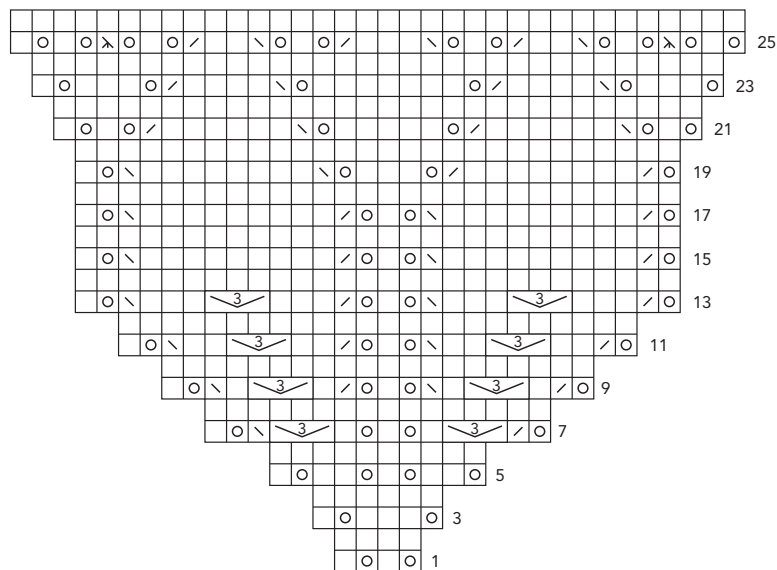
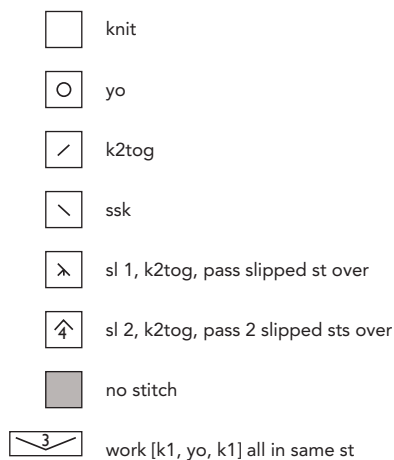



Back Diagram

Arrows show direction of knitting.

upper left back upper right back

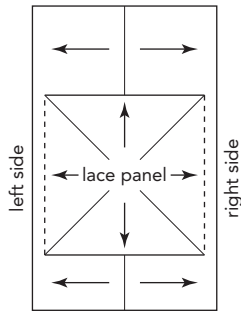

lower left back lower right back

from underarm.

Next rnd: K12 (15, 17, 19, 21), pm, work Rnd 1 of Chart C over 27 sts, pm, k12 (15, 17, 19, 21).

Work Rnds 2–30 of chart (25 chart sts rem after Rnd 27) and **at the same time**, cont to work sleeve dec rnd every 8 (8, 8, 7, 6)th rnd as established 1 (2, 1, 2, 2) more time(s)—47 (51, 57, 59, 63) sts rem; 25 center chart sts, 11 (13, 16, 17, 19) sts each side; sleeve measures 16½ (16½, 17½, 17½, 18½)" from underarm. Work even in St st for ½". Work seed st edging as foll:

Next rnd: K1, *p1, k1; rep from *.

Next rnd: P1, *k1, p1; rep from *.

Rep last 2 rnds until seed st measures 1½", and sleeve measures 18 (18, 19, 19, 20)" from underarm. BO all sts in patt.

FINISHING

Carefully remove provisional CO from center of lace panel, thread tail on a

Chart B

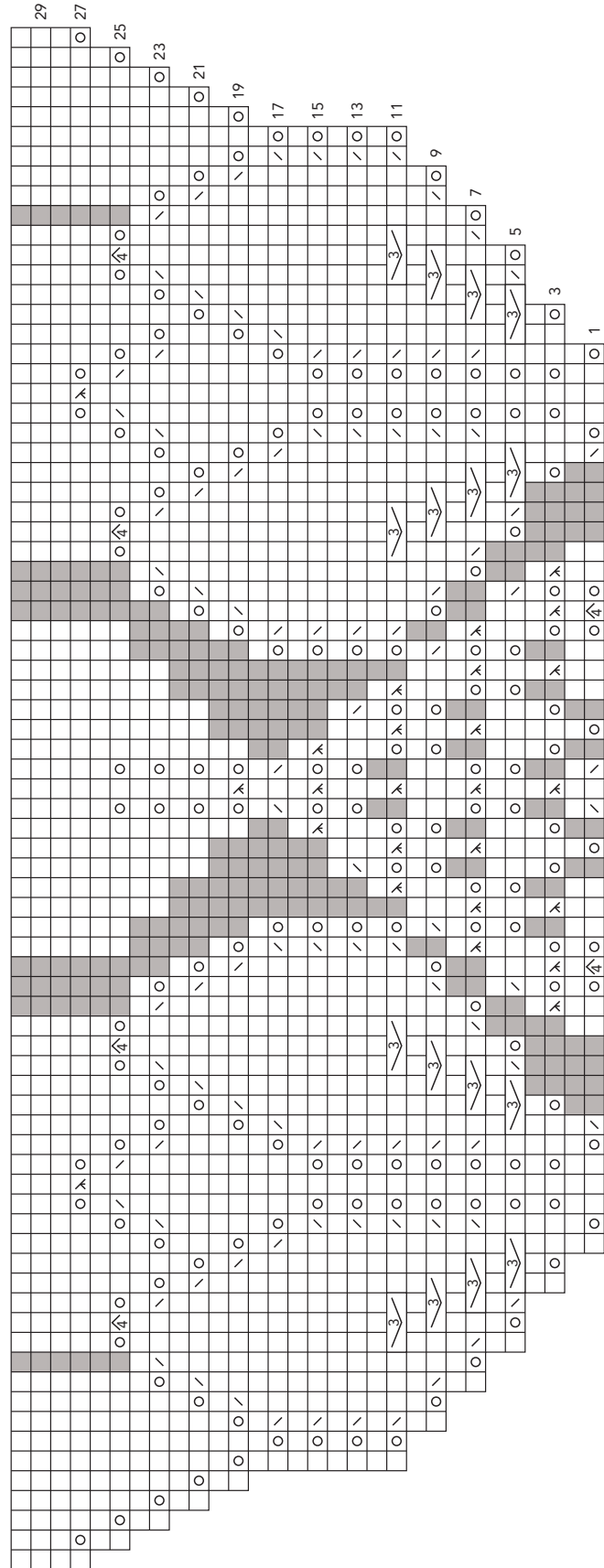



Patternworks™
Everything for the hand knitter & crocheter!

Meredith Bay Yarn

A classic wool with a touch of alpaca

Save \$5.00!

when you place any order of \$10.00 or more by September 16, 2011. Use promo code IK11F. Visit www.patternworks.com to see our entire product line, or call 1-800-438-5464 to order today.

one of life's little *luxuries*



Fine Kid Mohair Unbrushed
100% Kid Mohair Yarns
Mohair & Merino Wool Blends
Over 70 different colors
Designer patterns available



wagtail
yarns
mo hair yarns & garments

visit us online www.wagtailyarns.com.au

POST PO Box 87, Childers, Queensland 4660 Australia
PHONE +61 7 4126 7167 FAX +61 7 4126 7167
EMAIL wagtailyarns@bigpond.com

Introducing our first Fusion:
Teton

Mountain
Fusion

Inspired by and created in
the **Rocky Mountain West**

A Mountain Colors & Mountain Meadow Wool Collaboration

www.mountaincolors.com
www.mountainmeadowwool.com

ASHFORD WHEELS & LOOMS

Wild Carder

Create beautiful, fun, funky & wild batts ready to spin. Add wool, silk, cocoons, noils, ribbons, bits, pieces and more...



Includes cleaning brush, clamps and doffer.

Joy Spinning Wheel

Spin your own beautiful yarns on the Joy spinning wheel. Ultra compact, flyer and bobbin store in the frame, fold up the Joy and take it with you. Sturdy canvas carrybag available. Choose single or double treadle.



Knitters Loom

Weave garments or home furnishings with textured, fun knitting yarns. Quick and easy instructions included. Fully assembled, ready to weave. 12 or 20 inch weaving widths.

Just add yarn!



Portability in 2 sizes, 12 or 20 inch weaving widths. Stands & carry bags available.



USA Distributor:
Foxglove Fiberarts Supply
Phone (206) 780-2747
www.FoxgloveFiber.com



New

220 Superwash Sport

100% Superwash Merino Wool

Available in 50 colors

The only merino superwash sport good enough to be named 220®

Download the Melissa Leapman Pattern FREE at cascadeyarns.com



HALCYON YARN

Call for your free catalog, or drop by our shop in Bath, Maine.

Follow us on Facebook & Twitter!

HALCYONYARN.COM 800-341-0282



*Ruby Anniversary Celebration,
Forty Years of Halcyon Yarn!*



Special Ruby Edition
SWANS ISLAND
Ruby Anniversary Worsted

Organic merino wool,
naturally dyed in Maine.

-  knit
-  k1tbl
-  purl
-  yo
-  k2tog
-  ssk
-  k3tog
-  sl 1, k2tog, pass slipped st over

-  no stitch
 -  pattern repeat
- Fishnet**
- | | | | |
|---|---|---|---|
| ○ | ○ | ○ | ○ |
| ○ | ○ | ○ | ○ |
| ○ | ○ | ○ | ○ |
| ○ | ○ | ○ | ○ |

Increase

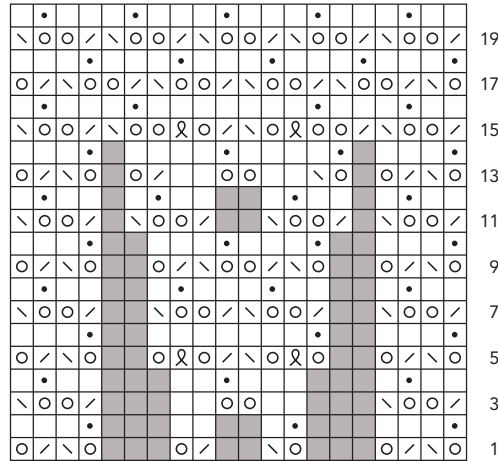

Toe

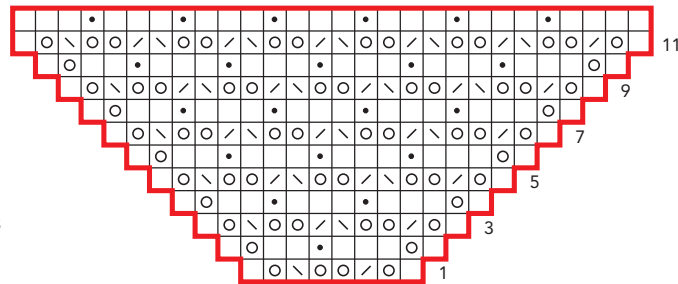

Decrease

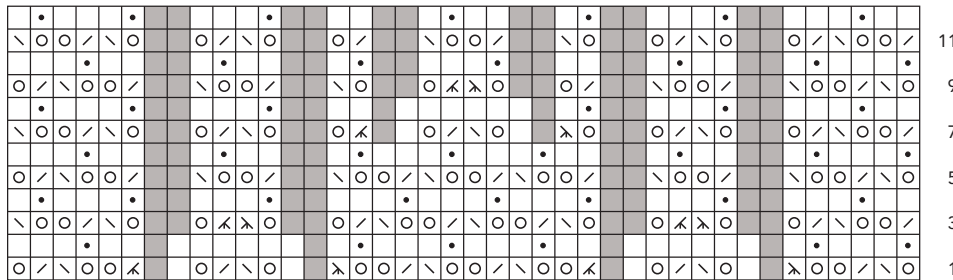

Thigh-High Cuff

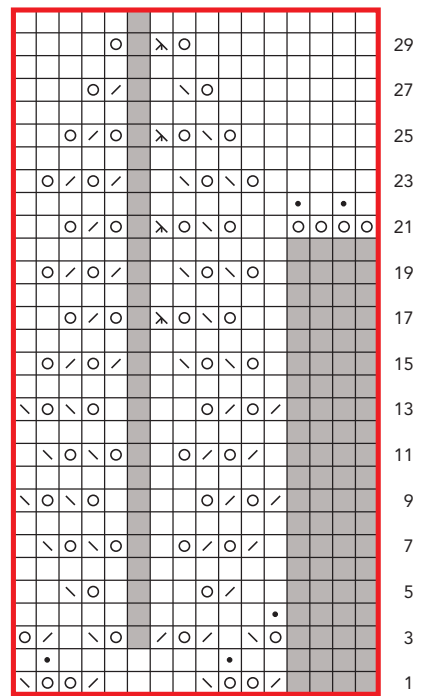

Knee-High Cuff

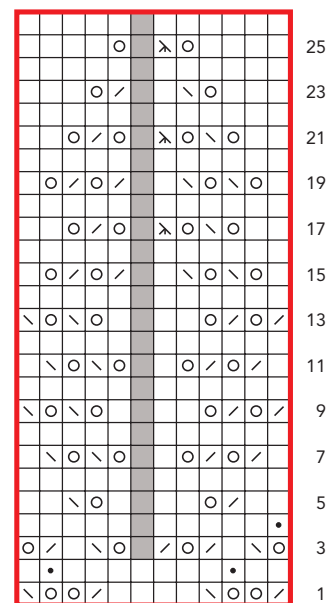

slip marker (sl m), work Rnd 1 of Increase chart to next m, sl m, work in established fishnet patt to end of rnd.

Keeping sts outside marked section in fishnet patt, work Rnds 2–20 of Increase chart, ending with Rnd 2 of fishnet patt—64 sts total; 36 sole sts arranged as 20 marked center sts and 8 sts outside markers at each side; 28 top-of-foot sts. Move each gusset marker 4 sts in toward the center of the sole so they are positioned after the 12th and 24th sts of the rnd—12 center sole sts between new marker positions. Keeping sts outside markers in fishnet patt, work Rnds 1–10 of Increase chart once more, ending with Rnd 4 of fishnet patt—68 sts total; 40

sole sts arranged as 16 marked center sts and 12 sts outside markers at each side; 28 top-of-foot sts. Remove gusset m, and work 2 rnds in fishnet patt on all sts, ending with Rnd 2 of patt.

Heel:

Next rnd: (Rnd 3 of fishnet patt) Work Rnd 1 of Decrease chart across 40 sole sts (dec them to 36 sts as shown on chart), work fishnet patt to end of rnd. Keeping top-of-foot sts in fishnet patt as established, work Rnds 2–12 of chart on sole sts, ending with Rnd 2 of fishnet patt—56 sts total rem; 28 sts each for sole and top of foot.

Calf: Work all sts in fishnet patt until leg measures 7 (4)" from start of heel shaping, or desired length to beg of calf shaping, ending with Rnd 2 of patt. Place removable markers for calf incs after the 8th and 20th sts of the rnd, on either side of the center 12 back-of-leg sts—back-of-leg sts are arranged as 12 marked center sts and 8 sts outside markers at each side.

Next rnd: (Rnd 3 of fishnet patt) Work 8

Fringe Benefit



Shown in Kauni Effektgarn

see all 6 new scarf patterns from

Knitting At KNoon Designs

at www.KnittingAtKNoon.com

Patterns for timeless knits
KnittingAtKNoon.com
616.538.0958



CASCADE YARNS
DISTRIBUTOR OF FINE YARNS

220 Sport

100% Peruvian Highland Wool

Available in 59 colors

The only sport weight yarn
reliable enough to
be labeled 220*

Download the Nancy Rieck
Pattern FREE at cascadeyarns.com



Sooner or later ...
every knitter needs to

Fix-A-Stitch™

Garter stitch .. easiest to knit ..
hardest to repair .. until

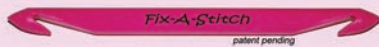

- ✗ Knit or Purl repairs from the front of a garter stitch fabric
- ✗ Seed stitch corrections are simple
- ✗ Small and light .. parks in your work
- ✗ Use it to hold cable stitches

Instructions, videos &
where to buy:
www.fixastitch.com
920-fix-stch (349-7824)



PIECEWORK

Honoring the Rich
History of Needlework

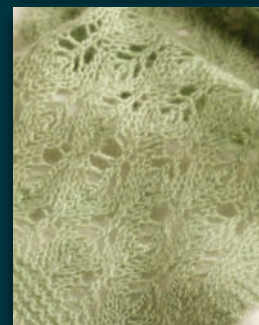

6 issues for \$24 • pieceworkmagazine.com

sts in established fishnet patt to m, sl m, work Rnd 1 of Increase chart to next m, sl m, work in established fishnet patt to end of rnd.

Keeping sts outside marked section in fishnet patt, work Rnds 2–20 of Increase chart, ending with Rnd 2 of fishnet patt—64 sts total; 36 back-of-leg sts arranged as 20 marked center sts and 8 sts outside markers at each side; 28 front-of-leg sts. *Move each chart marker 4 sts in toward the center of the back of the leg to mark the center 12 back-of-leg sts again. Working sts outside marked section in fishnet patt, work Rnds 1–20 of Increase chart once more—8 sts inc'd on back of leg. Rep from * 0 (2) more time(s), ending with Rnd 2 of fishnet patt—72 (88) sts total; 44 (60) back-of-leg sts; 28 front-of-leg sts.

For smaller size only: Move each chart marker 4 sts in toward the center of the

back of the leg to mark the center 12 back-of-leg sts again. Working sts outside marked section in fishnet patt, work Rnds 1–8 of Increase chart once more, ending with Rnd 2 of fishnet patt—76 sts total; 48 back-of-leg sts; 28 front-of-leg sts.

For both sizes: Remove calf shaping m, and work fishnet patt on all sts until leg measures 4" from end of calf incs, or 3" shorter than desired finished length, ending with Rnd 2 (4) of patt. Place removable markers for calf decs on either side of the center 40 back-of-leg sts—back-of-leg sts are arranged as 40 marked center sts and 4 (10) sts outside markers at each side.

Next rnd: (Rnd 3 [1] of fishnet patt) Work 8 (10) sts in established fishnet patt to m, sl m, work Rnd 1 of Decrease chart across 40 marked sts (dec them to 36 sts as shown on chart), sl m, work in established fishnet patt to end of rnd.

Keeping sts outside marked section in fishnet patt, work Rnds 2–6 of Decrease chart, ending with Rnd 4 (2) of fishnet patt—72 (84) sts total; 44 (56) back-of-leg sts; 28 front-of-leg sts.

Cuff: Remove calf shaping m, and work 2 (0) rnds even, ending with Rnd 2 of fishnet patt. Remove end-of-rnd m, work 6 sts as yo, ssk, k4, replace m—end-of-rnd has moved 6 sts to the left. Work Rnds 1–26 of Knee-high Cuff chart—66 (77) sts rem. Work picot BO as foll: *CO 3 sts using the cable method (see Glossary), BO 5 sts, slip st on right needle after last BO back to left needle; rep from * until 1 (2) sts rem, then BO rem sts. Break yarn and fasten off last st.

THIGH-HIGH STOCKING

Work as for knee-high stocking until leg measures 4" from end of calf incs, ending

The original inspiration for these stockings was the way that Herbert Niebling incorporates increases into background mesh. I thought that his method would be an interesting way to add calf and thigh shaping to fishnet stockings. Niebling knitters affectionately call this particular mesh 'hex mesh,' after the hexagons that the double yarnover eyelets are pulled into by their surrounding decreases.

—REBECCA BLAIR



JUDY'S MAGIC CAST-ON

This amazingly simple cast-on is named for its founder, Judy Becker. It wraps the yarn around two parallel needles in such a way as to mimic a row of stockinette stitch between the two needles.

Leaving a 10" (25.5 cm) tail, drape the yarn over one needle, then hold a second needle parallel to and below the first and on top of the yarn tail (Figure 1).

Bring the tail to the back and the ball yarn to the front, then place the thumb and index finger of your left hand between the two strands so that the tail is over your index finger and the ball yarn is over your thumb (Figure 2). This forms the first stitch on the top needle.

*Continue to hold the two needles parallel and loop the finger yarn over the lower needle by bringing the lower needle over the top of the finger yarn (Figure 3), then bringing the finger yarn up from below the lower needle, over the top of this needle, then to the back between the two needles.

Point the needles downward, bring the bottom needle past the thumb yarn, then bring the thumb yarn to the

front between the two needles and over the top needle (Figure 4).

Repeat from * until you have the desired number of stitches on each needle (Figure 5).

Remove both yarn ends from your left hand, rotate the needles like the hands of a clock so that the bottom needle is now on top and both strands of yarn are at the needle tip (Figure 6).

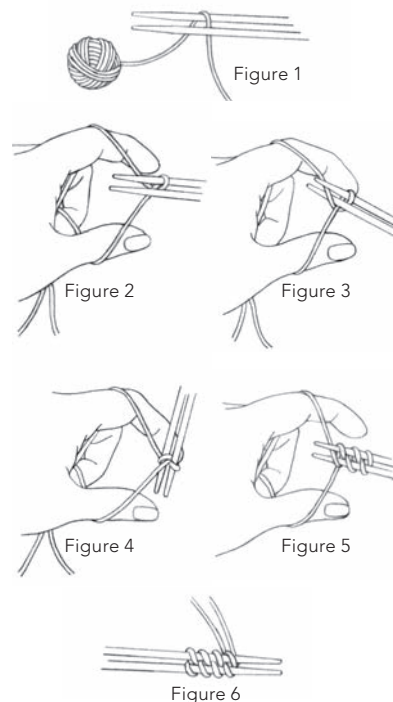

BROOKLYN GENERAL STORE

where country fiber warms the big city



Classes in knitting, sewing, felting, upholstery, rug hooking, embroidery, crochet, quilting, spinning and more.



Come on in and relax in Brooklyn's original and classic country store. Leave behind the city swirl and be enchanted and inspired by the goods.

www.BrooklynGeneral.com

128 Union Street, Brooklyn, NY



128 Superwash

100% Superwash Merino Wool

Available in 64 colors

Pure and Simple
Love it after washing

Download this Betty Balcomb
Pattern FREE at cascadeyarns.com



A World of Inspiration A World of Creations

Explore the history of knitting from around the globe, including:
England • Ireland • Australia • Japan • And beyond

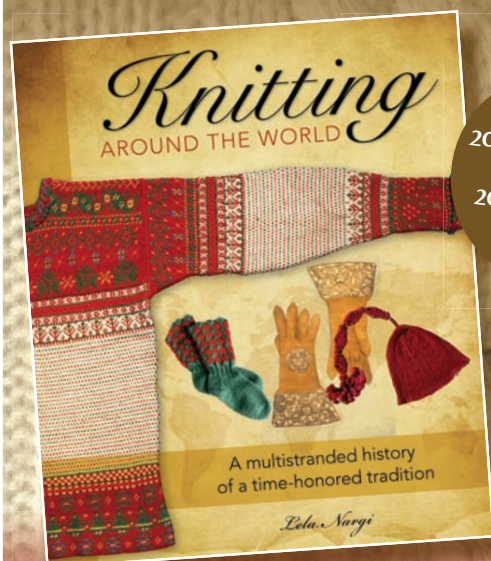

Plus, explore
20 knitter profiles
and
20 international
patterns!



Available online and at your local bookstore!
voyageurpress.com



Andalucia Scarf
by Abbott Smith
Jamieson's Spindrift



simply shetland

Exclusive North American distributor of
Jamieson's Shetland yarns

Visit simplyshetland.com for your local retailer

CUSTOMIZE IT

You can achieve a custom fit by working more or fewer increases and decreases wherever the legs they are destined to fit become wider or narrower. To incorporate the shaping into the pattern smoothly, just make sure that each set of increases or decreases is continuous with the fishnet pattern below it, as shown in the chart. For stockings that become wider more quickly, work two or more sets of increases in the same round.



with Rnd 2 (4) of patt—76 (88) sts total; 48 (60) back-of-leg sts; 28 front-of-leg sts. Do not work calf decs.

Knee: Place removable markers for knee decs on either side of the center 40 back-of-leg sts—back-of-leg sts are arranged as 40 marked center sts and 4 (10) sts outside markers at each side.

Next rnd: (Rnd 3 [1] of fishnet patt) Work 8 (10) sts in established fishnet patt to m, sl m, work Rnd 1 of Decrease chart across 40 marked sts (dec them to 36 sts as shown on chart), sl m, work in established fishnet patt to end of rnd. Keeping sts outside marked section in fishnet patt, work Rnds 2–12 (Rnds 2–4) of Decrease chart, ending with Rnd 2 (4) of patt—64 (80) sts total; 36 (52) back-of-leg sts; 28-front-of-leg sts. Remove knee dec m, and work fishnet patt on all sts until leg measures 3" from end of knee decs, ending with Rnd 2 of patt.

Thigh: Place removable markers for thigh incs on either side of the center 12 back-of-leg sts—back-of-leg sts are arranged as 12 marked center sts and 12 (20) sts outside markers at each side.

Next rnd: (Rnd 3 of fishnet patt) Work 12 (20) sts in established fishnet patt to m, sl m, work Rnd 1 of Increase chart to next m, sl m, work in established fishnet patt to end of rnd.

Keeping sts outside marked section in fishnet patt, work Rnds 2–20 of Increase chart, ending with Rnd 2 of fishnet patt—72 (88) sts total; 44 (60) back-of-leg sts arranged as 20 marked center sts and 12 (20) sts outside markers at each

side; 28 front-of-leg sts. *Move each chart marker 4 sts in toward the center of the back of the leg to mark the center 12 back-of-leg sts again. Working sts outside marked section in fishnet patt, work Rnds 1–20 of Increase chart once more—8 sts inc'd on back of leg. Rep from * 2 (3) more time(s), ending with Rnd 2 of fishnet patt—96 (120) sts total; 68 (92) back-of-leg sts; 28 front-of-leg sts. Remove thigh inc m, and work fishnet patt on all sts until leg measures 4 (5)" from end of thigh incs, or 3½" shorter than desired finished length, ending with Rnd 2 of patt.

Cuff: Remove end-of-rnd m, work 6 sts as k2, k2tog, yo twice, ssk, replace m—end-of-rnd has moved 6 sts to the left. Work Rnds 1–20 of Thigh-high Cuff chart—88 (110) sts rem. In Rnd 21, work the quadruple yo at the start of each patt rep by wrapping yarn 4 times around needle. In Rnd 22, work the quadruple yo at the start of each patt rep by dropping 3 of the 4 wraps, then work [k1, p1] 2 times as shown on chart all in the rem elongated st—120 (150) sts after completing Rnd 22. Work Rnds 23–30 of chart. Work crochet chain (ch) BO as foll (see Glossary for crochet sts): With crochet hook, k3tog tbl, *ch 10, k3tog tbl, yarn over hook and draw through both sts on hook; rep from * until no cuff sts rem, ch 10, work a slip stitch into first k3tog tbl of BO rnd. Break yarn and fasten off last st.

FINISHING

Weave in ends, leaving 2" to 4" tails. Block stockings to desired measurements by soaking them in lukewarm water, gently

squeezing out the excess water in a towel, and laying them flat to dry. Pin out each picot point or crochet loop along the top edge, if desired. When stockings are completely dry, carefully trim tails of woven-in ends flush with surface of fabric.

Rebecca Blair is a lace knitter and doily enthusiast in southern Ontario, Canada.



FERN LACE STOLE

Mareike Sattler

Finished Size 10" wide and 76½" long.
Yarn Filatura di Crosa Superior (70% cashmere, 30% silk; 328 yd [300 m]/⅞ oz [25 g]): #46 royal purple, 3 balls. Yarn distributed by Tahki Stacy Charles.

Needles Sizes 0 (2 mm), 3 (3.25 mm), and 7 (4.5 mm): 47" circular (cir). Adjust needle size if necessary to obtain the correct gauge.

Notions Markers (m); tapestry needle; 3 strands of smooth sportweight yarn in contrasting color, 3 yd each.

Gauge 22 sts and 22 rows = 4" in shell patt on largest needle.

NOTES

- Instead of pulling the waste yarn out after it has served its purpose, leave it in and use it as a lifeline.
- Because of the large number of stitches on the needle and the techniques used in this pattern, check the stitch count often.

Stitch Guide

Sl2tog, k1, p2sso: Sl 2 as if to k2tog, k1, pass 2 sl sts over knit st—2 sts dec'd (vertical dec).

Sl1, k2tog, pssso: Sl 1 kwise, k2tog, pass slipped st over—2 sts dec'd (left-slanting dec).

Cluster 2: Sl 2 pwise with yarn in back (wyb), bring yarn to front between needles, sl same 2 sts back to left needle, bring yarn to back between needles, sl

Takumi Combo Set

Interchangeable Circular Knitting Needles



60 combinations

Includes:

- 5 cords
- 12 tip sizes
- Luxury case



CLOVER MFG. CO., LTD.

Ontario, CA 91761 Toll: 1-800-233-1703
www.clover-usa.com Tel: 1-909-218-2160

CN CLOVER NEEDLECRAFT, INC.

The Fibre Company
distributed by Kelbourne Woolens



www.TheFibreCo.com
www.KelbourneWoolens.com



Jackson
by: Courtney Kelley
Featuring Road to China Light

COLLECTION 4: HEARTLAND

a collection of sweaters + accessories
inspired by the rustic midwest

Tulip Lace Cardigan

designer
Linda Daniels

in Merino
Melangé



the **Frog Tree**[®]
COLLECTION

A NOT-FOR-PROFIT COMPANY

www.FrogTreeYarns.com

eUCALAN[®]

no rinse | delicate wash

perfect for laundering: cashmere • wool • alpaca
cotton • silk • mohair...and more!



grapefruit
lavender
unscented
eucalyptus

a whole new spin on laundry!
and On The Go Clothing Care™ line

www.eucalan.com

1.800.561.9731

same 2 sts to right needle pwise wyb.

Cluster 3: Work as for cluster 2, sl 3 sts each time.

Cluster 5: Work as for cluster 2, sl 5 sts each time.

Alternate Bind-Off: When binding off stitches, if it feels cumbersome to catch the 2 strands of lace yarn when knitting 2 stitches together through the back loops, try binding off very loosely (keeping the stitch on the right needle about ½" long) as foll:

Step 1: K2tog tbl at beg of needle.

Step 2: Insert right needle from right to left into next st on left needle.

Step 3: Insert left needle from left to right into st on right needle. (There should be 2 sts on 2 needles: left needle in front, right needle in back.)

Step 4: With right needle, catch working yarn and pull through both sts, dropping sts from left needle.

Rep Steps 2–4 until 1 st rem. Fasten off last st.

SHAWL

With largest needle, CO 421 sts. Do not join. Knit 1 WS row. ****Shell patt:**

Row 1: (RS) Sl 1, place marker (pm), k1, *yo, [k1tbl, p3] 5 times, k1tbl, yo, pm, k1; rep from * to last st, k1—459 sts.

Row 2: (WS) Sl 1, *p1, sl m, p1, p1tbl, [k3, p1tbl] 5 times, p1; rep from * to last 2 sts, p1, sl m, k1.

Row 3: Sl 1, sl m, k1, *yo, k1tbl, yo, [k1tbl, p3] 5 times, [k1tbl, yo] 2 times, sl m, k1; rep from * to last st, k1—535 sts.

Row 4: Sl 1, *p1, sl m, p3, p1tbl, [k3, p1tbl] 5 times, p3; rep from * to last 2 sts, p1, sl m, k1.

Row 5: Sl 1, sl m, k1, *yo, k1tbl, yo, ssk, yo, [k1tbl, p2tog, p1] 5 times, k1tbl, yo, k2tog, yo, k1tbl, yo, sl m, k1; rep from * to last st, k1—516 sts rem.

Row 6: Sl 1, *p1, sl m, p5, p1tbl, [k2, p1tbl] 5 times, p5; rep from * to last 2 sts, p1, sl m, k1.

Row 7: Sl 1, sl m, k1, *k1tbl, [yo, ssk] 2 times, yo, [k1tbl, p2] 5 times, k1tbl, yo, [k2tog, yo] 2 times, k1tbl, sl m, k1; rep from * to last st, k1—554 sts.

Row 8: Sl 1, *p1, sl m, p6, p1tbl, [k2, p1tbl] 5 times, p6; rep from * to last 2 sts, p1, sl m, k1.

Row 9: Sl 1, sl m, k2, *yo, k2tog] 2 times, yo, k1tbl, yo, [k1tbl, p2tog] 5 times, [k1tbl, yo] 2 times, [ssk, yo] 2 times, k1, sl

m, k2; rep from * to end—535 sts rem.

Row 10: Sl 1, *p1, sl m, p8, p1tbl, [k1, p1tbl] 5 times, p8; rep from * to last 2 sts, p1, sl m, k1.

Row 11: Sl 1, sl m, ssk, *yo, k2tog] 3 times, k1tbl, yo, [k1tbl, p1] 5 times, k1tbl, yo, k1tbl, [ssk, yo] 3 times, pm, sl2tog, k1, p2sso (see Stitch Guide; removing m); rep from * to last 28 sts, yo, k2tog] 3 times, k1tbl, yo, [k1tbl, p1] 5 times, k1tbl, yo, k1tbl, [ssk, yo] 3 times, pm, k2tog (removing m), k1.

Row 12: Sl 1, *p1, sl m, p8, p1tbl, [k1, p1tbl] 5 times, p8; rep from * to last 2 sts, p1, sl m, k1.

Row 13: Sl 1, remove m, k1, *[k2tog, yo] 2 times, k2tog, k1, k1tbl, yo, [ssk] 2 times, sl1, k2tog, psso (see Stitch Guide), [k2tog] 2 times, yo, k1tbl, k1, ssk, yo, ssk] 2 times, remove m, k1; rep from * to last st, k1—421 sts rem.

Row 14: Sl 1, cluster 2 (see Stitch Guide), *p7, cluster 5, p7, cluster 3; rep from * to last 22 sts, p7, cluster 5, p7, cluster 2, k1.

Change to middle-size needle. **Picot pleat:**

Row 1: (RS) Sl 1, knit to end.

With 1 strand of waste yarn threaded on a tapestry needle, insert tapestry needle pwise into each st on cir needle; do not drop sts from cir needle. After waste yarn is threaded through all sts, let ends of waste yarn hang evenly at each end of piece. (This inserted yarn serves as a guide for picking up sts later to form the pleat.) Cont as foll, being careful not to catch waste yarn while working:

Row 2 and all WS rows: Sl 1, purl to last st, k1.

Rows 3 and 5: Rep Row 1.

Row 7: Sl 1, *yo, k2tog; rep from * to end.

Rows 9 and 11: Rep Row 1.

Row 12: Rep Row 2.

Insert smallest needle along same row as waste yarn, foll path of waste yarn with needle—421 sts. With RS facing, hold smallest needle behind middle-size needle; St st strip will fold to RS along picot edge (Row 7) to form pleat.

Row 13: With middle-size needle, *k2tog (1 st from front needle and 1 st from back needle); rep from * to end—421 sts.

Row 14: Sl 1, purl to last st, k1.

Change to largest needle. Rep from ** 2 more times, then work Rows 1–13 of shell patt once more. **Next row:** (WS) K1, k2tog, *k7, k3tog, k2tog, pass 2nd st on right needle over first st, k7, k3tog; rep from * to last 22 sts, k7, k3tog, k2tog, pass 2nd st on right needle over first st,

k7, k2tog, k1—307 sts rem. **BO row:** (see Stitch Guide) **Note:** Keep st on right needle very loose, about ½" long; exact st size will depend on your gauge. *K2tog tbl, sl st back to left needle; rep from * until 1 st rem. Fasten off last st.

FINISHING

Carefully remove waste yarn. Weave in loose ends. Wash and block piece. To give definition to long edges of scarf, pull out and secure waves along scarf edge with pins or blocking wires.

Growing up in Germany, *Mareike Sattler* learned to knit from her mother at an early age. When she moved to the southern United States, she thought she'd have little use for wool garments, but she soon discovered that wool is the perfect antidote to excessive air-conditioning. She now lives with her family in Nashville, Tennessee.

• • • • •

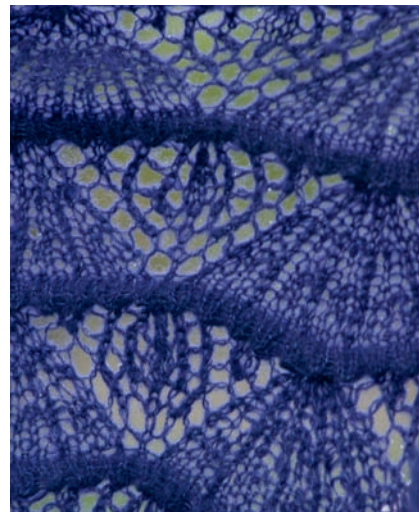

Tech Tip

Instead of using a lifeline to save stitches for welting, consider using a very small, long circular needle—when it's time to knit the stitches together, the welt stitches will be ready and waiting, all ready to knit.

ALL IN THE DETAILS

Mango Moon's Jasmine cardi, exclusively ours from designer Therese Chynoweth, has details you'll love:

- asymmetrical frog closure with inside button
 - linen stitch collar & cuffs
 - rolled edges
 - cable-shaped waist



The yarn is Dharma, our fabulously soft, 100% recycled silk, handspun just for us in Nepal and overdyed in 16 amazing shades.

Want to see more? Visit us online or ask at your favorite yarn shop today!

mangomoon
mangomoon yarns.com

addi Turbo®

accept no substitutes...



www.skacelknitting.com

Southern Adirondack Fiber Tour

SEPTEMBER 21-25

Spectacular scenery and outdoor experiences in the heart of New York's Upper Hudson Valley



iloveny.com

Spinning, dyeing, and felting workshops | Locally grown foods and wine tastings | Fiber farm tours | Yarn production facility visit - Battenkill Fibers Carding & Spinning Mill | Admission to Southern Adirondack Fiber Festival

Four nights, five days from \$299/person. Optional New York City and airport pick-up. For detailed itinerary and registration information: 888-203-8622 | www.washingtonnycounty.com

TILLI TOMAS

SOCK

- hand dyed in artisan batches



Fickle Knitter Design

www.tillitomas.com 617-524-3330



WHEELED LACE SHAWL

Kristin Omdahl

Finished Size 60" wide x 30" tall at center.

Yarn Shibui Knits Silk Cloud (60% kid mohair, 40% silk; 330 yd [300 m]/% oz [25 g]): #SC350 storm, 2 skeins.

Needles Size 6 (4 mm): 24" or longer circular (cir) and set of 2 double-pointed (dpn). Adjust needle size if necessary to obtain the correct gauge.

Notions Markers (m); tapestry needle; pins for blocking.

Gauge 16 sts and 16 rows = 4" in patt, after blocking.

Stitch Guide

S2kp2: Sl 2 as if to k2tog, k1, p2sso—2 sts dec'd.

SHAWL

CO 17 sts. Do not join. **Next row:** (WS) K1, place marker (pm), k7, pm, k1, pm, k7, pm, k1. **Next row:** K1, sl m, work Row 1 of Medallion chart to m, sl m, k1, sl m, work Row 1 of chart to m, sl m, k1—21 sts. Cont in patt (keeping first, center, and last st in garter st), work Rows 2–16 of chart once, then work Rows 17–32 six times, adding one more 16-st rep on each side each time—241 sts. **Note:** Remove m on next row. **Next row:** (RS) K1, yo, knit to m, yo, k1, yo, knit to last st, yo, k1—245 sts. Knit 1 WS row. BO all sts.

FINISHING

Block shawl to 56" wide at upper edge and 28" tall at center, pinning lower V edge at every medallion, between every medallion, at center point, and at 2 side points (beg and end of BO row)—33 pins. Pin as desired along top edge. Pinned points along lower V edge serve as guides for joining medallion edging. **Edging:** With dpn, CO 3 sts. Do not join.

Row 1: (RS) K1f&b, yo, k2—5 sts.

Rows 2, 4, 8, and 10: Knit.

Row 3: K2, yo, k1, yo, k2—7 sts.

Row 5: K2, yo, k3, yo, k2, pick up and knit 1 st in point at lower edge of shawl—10 sts.

Row 6: K2tog, knit to end—9 sts rem.

Row 7: K1, ssk, yo, s2kp2 (see Stitch Guide), yo, k2tog, k1—7 sts rem.

Row 9: K1, ssk, yo, k3tog, k1—5 sts rem.

Row 11: Ssk, k1, k2tog—3 sts rem.

Row 12: P3tog—1 st rem.

Row 13: Knit into front, back, and front of same st—3 sts.

Row 14: Knit.

Rep Rows 1–14 thirty-one more times, then work Rows 1–12 once more—33 medallions, each joined to lower edge of shawl at one of 33 points created in blocking shawl. Fasten off last st. Steam block medallion edging to flatten medallions. Weave in ends.

Kristin Omdahl delights in tropical living on the Florida coast and having fun outside with her son every day. Her books include *Seamless Crochet*, *A Knitting Wrapsody*, *Crochet So Fine*, and *Wrapped in Crochet*, all from Interweave. She is the crochet expert on *Knitting Daily TV*, and she offers several DVD workshops on knitting and crochet.



Medallion

16-st repeat

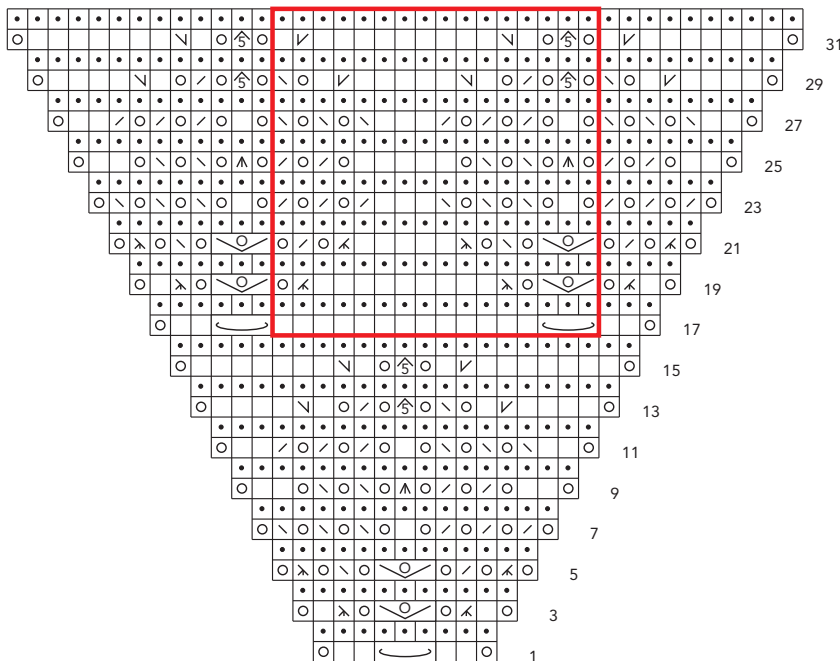

k on RS; p on WS

p on RS; k on WS

yo

k2tog

ssk

k3tog

sl 1, k2tog, p3sso

sl 2 as if to k2tog, k1, p2sso

knit into side of st below st on left needle but do not drop st from left needle

knit into side of st 2 rows below st on right needle

sl 3 as if to k3tog, k2tog, p3sso

pattern repeat

sl 3 pwise wyf, take yarn to back, sl same 3 sts to left needle, k3

(k1, yo, k1) in same st

Strauch Fiber Equipment Co.

We Handcraft It All . . . With You In Mind

Up to 11lb
of yarn



Wind your skeins into *big,*
beautiful, center pull
balls with the Strauch
Jumbo Ball Winder.

Check out our website
for our complete line
of products and to find
a dealer near you:



www.strauchfiber.com

Follow us on Facebook, Twitter & Our Blog on TypePad

Otto & Joanne Strauch • 10319 Johns Creek Road, New Castle, VA 24127
540-864-8869 • ors@strauchfiber.com



indulge
your passion for knitting

Vermont's Best Yarn Shop
Shipping thousands of orders worldwide

kaleidoscope
YARNS®

[SHOP ONLINE] www.kyarns.com

US shipping just \$4.95! FREE SHIPPING on orders over \$75!

Sign up for exclusive savings! kyarns.com/newsletter

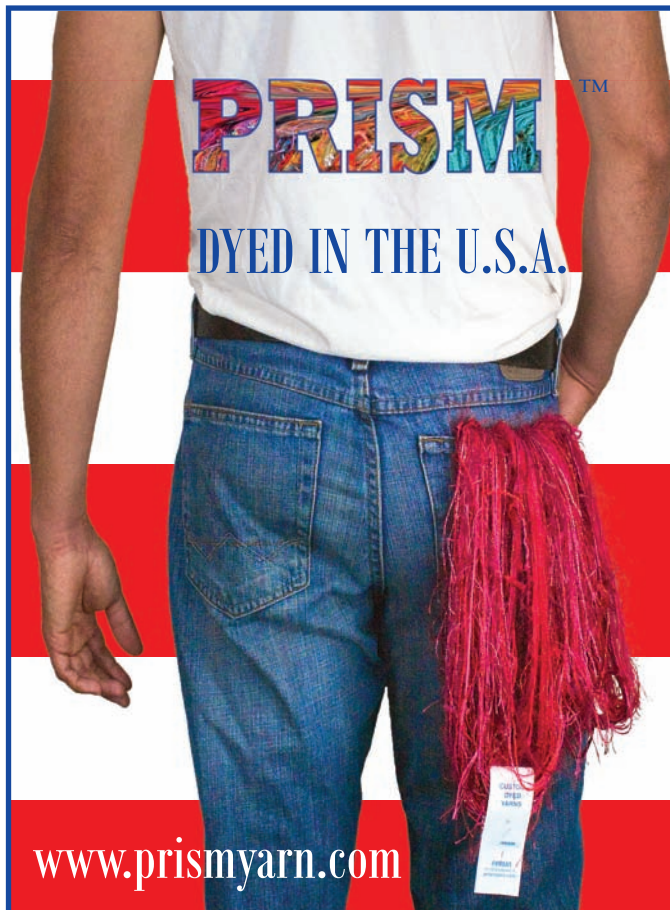

www.prismyarn.com



Stainless Steel
Sock Blockers



More air flow for faster drying!

for your nearest retailer
visit www.brysonknits.com
800-544-8992

Bryson Distributing



ODESSA REICHEL'S TRUE NORTH MITTENS draw images from cold Canadian winters—snowflakes, deer, and evergreens—and render them in stranded colorwork for plush warmth. A Latvian braid at the cuff keeps them snug around the wrist, while a wool, mohair, and angora tweed lends rustic softness to graphic patterning.
PAGE 108. YARN Berroco Blackstone Tweed

the
Teleidoscope
Turns

Color and pattern
everywhere—every way

Little Bunnies



SANDY CUSHMAN patterns the **RIO CAPELET** in simple vertical stripes that show off the thick-and-thin texture of a silk/wool blend singles yarn. A dramatic graphic lozenge band around the hem gives weight and swing to an easy first colorwork project. **PAGE 110.** YARN Tahki Yarns Rio, distributed by Tahki Stacy Charles



the
Teleidoscope
Turns

"Angel Fire is a small town tucked into a pass in the mountains of northern New Mexico. I remember cruising through the snow-blanketed town, the sun fading fast, on my way to Santa Fe. It seemed like a dream, a silent outpost in the sky, one of those magical New Mexico moments."—**LISA SHROYER**. The **ANGEL FIRE JACKET** is a refined, tailored nod to the classic Southwestern jacket with clean-finished mitered bands and geometric stranded colorwork worked in rows. **PAGE 112. YARN** Cascade Yarns Eco+





MARY JANE MUCKLESTONE'S BORDER SOCKS are made for lounging with the paper on a crisp fall Sunday morning. Fair Isle peerie patterns across the cuff, a wide rib foot, and a surprising chocolate toe wink at frugal knitting traditions without sacrificing fit. **PAGE 122. YARN** Plymouth Yarn Alpaca Prima



A man with a beard and short brown hair is shown from the waist up, looking off to the side with a slight smile. He is wearing a dark grey and white marled wool cardigan with a large-scale snowflake motif. The cardigan has a center placket with buttons and a hemmed buttonband. Underneath, he wears a red polo shirt. The background is a blurred outdoor setting, possibly a street or courtyard.

A rustic marled wool in dark and light colors has just enough contrast to make a large-scale snowflake motif readable in a tweedy fabric. Easy raglan shaping, a center steek, and a sleek hemmed buttonband come together for the tradition-tweaking **CANYON CARDIGAN. EUNNY JANG. PAGE 118.** **YARN** Tahki Yarns Jackson, distributed by Tahki Stacy Charles

the
Teleidoscope
Turns



the
Teleidoscope
Turns

ANNIE MODESITT uses an unusual caught-float technique to turn the wrong side of stranded colorwork into a textured right side in the **VARSITY STOLE**. Drapery alpaca keeps the stole warm but full of movement. **PAGE 124. YARN** Louet North America Eastport



ANN MCDONALD KELLY scales double knitting up for graphic impact in the **KELMSCOTT THROW**. A classic damask pattern goes modern at three-and-a-half stitches per inch in a piece with no wrong side. **PAGE 126.** YARN Harrisville Designs New England Highland



{Turn to page 16 for double-knitting how-to!}





TRUE NORTH MITTENS

Odessa Reichel

Finished Size 7¼ (9½)" hand circumference and 10 (12)" long. To fit women's (men's) medium. Mittens shown in smaller size.

Yarn Berroco Blackstone Tweed (65% wool, 25% superkid mohair, 10% angora; 130 yd [119 m]/1¼ oz [50 g]): #2601 clover honey (cream; A), #2608 quahog (brown; B), and #2637 plum island (purple; C), 1 skein each.

Needles Smaller size—size 5 (3.75 mm): set of 4 double-pointed (dnp). Larger size—size 7 (4.5 mm): set of 4 dnp. Adjust needle size if necessary to obtain the correct gauge.

Notions Marker (m); stitch holder; tapestry needle.

Gauge Smaller size: 25 sts and 31 rnds = 4" in colorwork patt. Larger size: 20 sts and 26 rnds = 4" in colorwork patt.

NOTES

- To mitigate any jog in the motifs or stripes when working mittens, don't carry yarn vertically between motifs.

- Break the yarn at the end of a section of patterning if it is not in the next, leaving a tail to weave in later.

Stitch Guide

Latvian Braid: (multiple of 3 sts)

Rnd 1: *K1 with A, k1 with B, k1 with C; rep from * around.

Rnd 2: Bring yarns to front. Keeping all 3 yarns in front throughout, *bring A under B and C and p1 with A, bring B under A and C and p1 with B, bring C under A and B and p1 with B; rep from * around.

Note: Yarns will be twisted tog after this rnd, but will untwist in the next rnd.

Rnd 3: With yarns in front, *bring A over B and C and p1 with A, bring B over A and C and p1 with B, bring C over A and B and p1 with C; rep from * around.

Corrugated Rib: (multiple of 3 sts)

Rnd 1: *P1 with A, bring A to back, k2 with C; rep from * around.

Rep Rnd 1 for patt.

MITTEN

Cuff: With A, CO 57 sts. Divide sts evenly onto 3 dnp. Place marker (pm) and join in the rnd. Purl 1 rnd. Work Rnds 1–3 of Latvian braid (see Stitch Guide). Work Rows 1–18 of Cuff chart—48 sts rem. Work corrugated rib (see Stitch Guide) for 3 rnds. Work Rows 1–19 of Mitten chart—65 sts. **Next rnd:** (Row 20 of chart) Place 17 thumb gusset sts on holder, work to end—48 sts rem. Work through Row 53 of chart—16 sts rem. Divide sts for front and back of mitten onto 2 needles. With C threaded on a tapestry needle, use

Tech Tip

M1L and M1R increases can shape colorwork without interrupting the pattern:

M1R:

Insert the left needle into the horizontal stitch between the last stitch worked and the next stitch on the left needle from back to front, bringing it onto the needle. Using the color indicated on the chart, knit through the front loop of this stitch.

M1L:

Insert the left needle into the horizontal stitch between the last stitch worked and the next stitch on the left needle from front to back, bringing it onto the needle. Using the color indicated on the chart, knit through the back loop of this stitch.

Kitchener st (see Glossary) to graft sts tog.

Thumb: Divide 17 thumb gusset sts onto 3 dnp. Pm and join in the rnd. Work Rows 1–14 of Thumb chart—8 sts rem. Divide sts for front and back of thumb onto 2 needles. With C threaded on a tapestry needle, use Kitchener st to graft sts tog.

FINISHING

Weave in ends and block.

Odessa Reichel lives in cold Manitoba, Canada, where mitten knitting is necessary. She likes to incorporate her love of color and her fine-art background into her work, which can be found on her blog at www.ohdessaknits.com.

CUSTOMIZE IT



Any bold color could be exchanged for the purple in the pattern for a different look—green for an earthier mitten, bright red for a more striking mitten, or a chestnut for a more traditional look.



	A		k2tog with B		ssk with B		MR	M1R with C
	B		k2tog with C		ssk with C		ML	M1L with B
	C		ssk with A		MR		ML	M1L with C
	k2tog with A							

Thumb

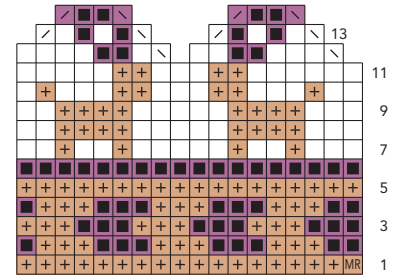

Cuff

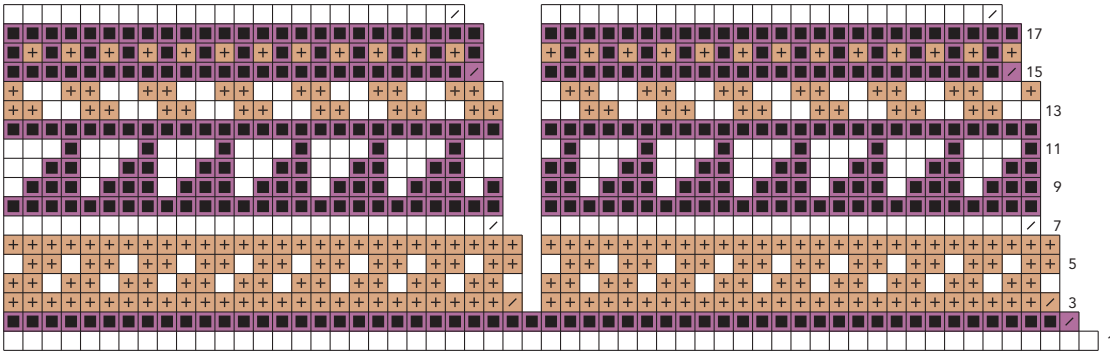

Mitten

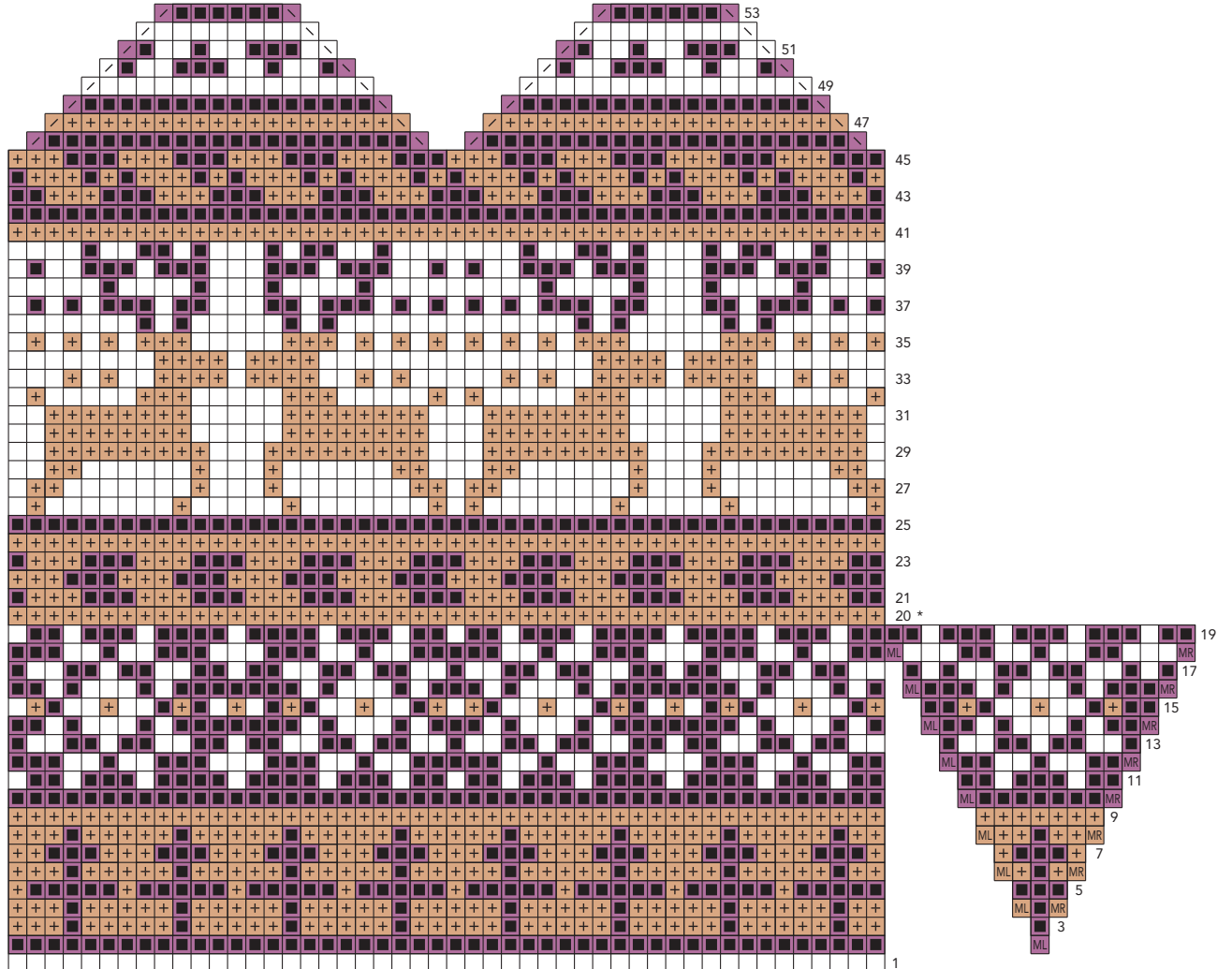



RIO CAPELET

Sandy Cushman

Finished Size 14¼ (16, 17¼)" neck circumference, 96 (108, 120)" lower edge circumference, and 20¼ (21¼, 22¼)" long, excluding turtleneck. Capelet shown measures 14¼".

Yarn Tahki Yarns Rio (50% alpaca, 35% merino wool, 15% silk; 87 yd [80 m]/1¼ oz [50 g]): #6 flint (gray; A), 8 (8, 9) skeins; #13 lake (blue; B), 4 (4, 5) skeins; #9 grape (C) and #1 ivory (D), 2 skeins each.

Needles Size 11 (8 mm): 16" and 40" circulars (cir). Size 9 (5.5 mm): 16" cir. Adjust needle size if necessary to obtain the correct gauge.

Notions Markers (m); waste yarn for provisional CO; tapestry needle.

Gauge 18 sts and 16 rows = 4" in stripe patt on larger needle; 16 sts and 16 rows = 4" in lozenge patt on larger needle.

BODY

With larger 16" needle, C, and using a provisional method (see Glossary), CO 64 (72, 80) sts. Place marker (pm) and join in the rnd. Knit 1 rnd. Cut C. **Next rnd:** *K2 with A, k2 with B; rep from * around. Maintaining stripe patt, shape back neck using short-rows (see Glossary) as foll:

Short-row 1: Work 17 (21, 25) sts in patt, wrap next st using A, turn.

Short-row 2: (WS) P34 (42, 50), wrap next st using A, turn.

Short-row 3: Work 17 (21, 25) sts in patt (to end of rnd).

Work 1 rnd, working wraps tog with wrapped sts as you come to them. Work Rows 1–27 of Stripes chart—384 (432, 480) sts. Work even in patt until piece measures 14 (15, 16)" from CO at center back. Cut B, but leave A attached; join C. With C, knit 2 rnds. Cut C. Work Rows 1–20 of Lozenge chart once. Cut A and D; join C. Knit 1 rnd. **I-cord BO:** CO 3 sts onto right needle. Sl 3 CO sts onto left needle. *[K2, sl 1 kwise, k1, pssso, sl 3 sts from right needle to left needle] 9 times, k2, sl 1 kwise, k2tog, pssso, sl 3 sts from

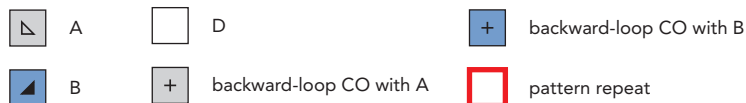

Stripes

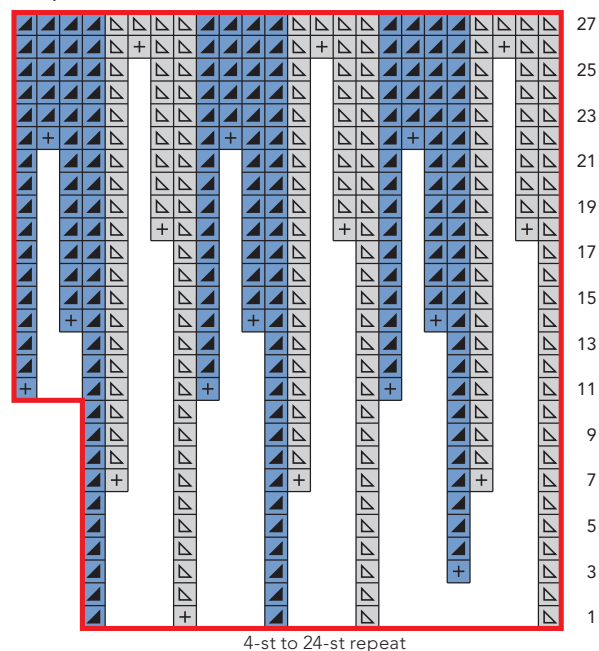

Lozenge

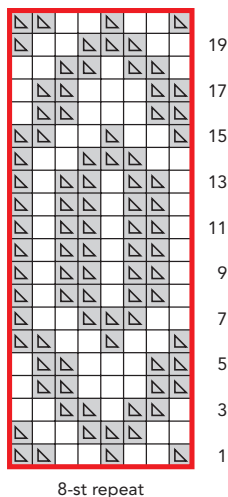

JADE SAPPHIRE
EXOTIC FIBRES

Cashmere from THE SOURCE

MOONLIGHT

50% MINK, 50% CASHMERE, HANDSPUN

When two luxury fibers meet and mingle,
the result is a romance for knitters



Mink and Cashmere
The Perfect Match

www.jadesapphire.com

www.colorful-stitches.com 800-413-6111



Colorful
STITCHES • 48 Main St., Lenox, MA 01240 •

TRY
OUR
SOLID
COLOR
SERIES



The Loopy Ewe
theloopyewe.com
(888) 527-9181

Fast Shipping and
Frequent Shopper
Benefits

90 COLORS

THE Web-sters



Rowan
Marion Foale
Madeline Tosh
Habu Textiles
Araucania
Louisa Harding
Sublime
Louet
Lantern Moon
Isager Yarns
Art Yarns
Berroco
Noro
Debbie Bliss
Koigu
Trendsetter
Plymouth
Brown Sheep
Manos
Colinette
Prism
Classic Elite
Mountain Colors
Elsebeth Lavold
Brittany Needles
Tahki • Stacy Charles
Simply Shetland

Rowan Magazine #50
\$24.00 plus S&H
Order from our Website
www.yarnatwebsters.com
THE WEB-STERS
11 N. MAIN STREET
ASHLAND, OR 97520
1-800-482-9801

right needle to left needle; rep from * until 3 sts rem on left needle. Turn; with WS facing, BO all sts.

FINISHING

Turtleneck: Remove provisional CO and place sts onto smaller needle—64 (72, 80) sts. Join C. **Next rnd:** *K2, p2; rep from * to end. Shape back neck using short-rows as foll:

Short-row 1: (RS) Work 17 (21, 25) sts in rib, wrap next st, turn.

Short-row 2: (WS) Work 34 (42, 50) sts in rib, wrap next st, turn.

Short-row 3: Work 17 (21, 25) sts in rib (to end of rnd).

Next rnd: Work in rib, working wraps tog with wrapped sts as you come to them. Join A.

Rnds 1 and 2: With A, work in rib.

Rnds 3 and 4: With C, work in rib.

Rep Rnds 1–4 until turtleneck measures 4½", ending with Rnd 4. BO all sts in patt. Weave in loose ends.

Sandy Cushman is a graduate of the Rhode Island School of Design, where she studied painting and textiles. Her knitting designs have been featured in many publications. She loves red wine and mountain and road biking. She teaches skiing in the winter (bumps and steeps only), gardens constantly, and travels as much as she can.



ANGEL FIRE JACKET

Lisa Shroyer

Finished Size 33¼ (37, 44½, 48½, 52¼)" bust circumference. Cardigan shown measures 37", modeled with 4" of ease.

Yarn Cascade Yarns Eco+ (100% Peruvian wool; 478 yd [440 m]/8¾ oz [250 g]): #2453 rust (MC), 2 (2, 3, 3, 3) skeins; #9451 teal (CC1) and #8014 cream (CC2), 2 skeins each.

Needles Sizes 8 and 9 (5 and 5.5 mm): 32" or longer circular (cir). Adjust needle size if necessary to obtain the correct gauge.

Notions Spare needles in larger size; tapestry needle; markers (m); stitch holders.

Gauge 16½ sts and 23 rows = 4" in single-color St st on smaller needle; 17 sts and 17 rows = 4" in stranded colorwork on larger needle.

NOTES

- Slip sts purlwise with yarn in front, except where indicated otherwise.
- This cardigan begins with the bottom band, which is worked in double knitting in a long strip with mitered corners at each end. Because of these mitered corners, the bottom band

turns and is worked vertically up the fronts, simultaneously with the body. Stitches for the body are picked up along the top edge of the bottom band.

- The bands continue in main color throughout. Work intarsia twists between the band stitches and the body stitches, even when the body color is also main color.
- Because the double knitting is compressed—it takes two rows of double knitting to achieve one row of double knitting—the band will be shorter than the body. To alleviate this effect, short-rows are worked across the bands every fourth row.
- Because the gauge from colorwork to single-color stockinette differs, the single-color sections are worked on a smaller needle than the colorwork. But because the bands need to be worked on the larger needle throughout, you will be working the bands on the larger needle and the body stitches on the smaller needle on the same row throughout the single-color sections of the body. This is a little confusing at first; just check which needle you're picking up each time and don't let them get tangled. You can also work the bands on double-pointed needles, to keep the circular cables from getting tangled.
- Because the repeat of the charted pattern is fairly large, the sizes jump from some overlap, to no overlap, to several inches of overlap. Some sizes (as shown) have fronts that only just meet in front. Since the cardigan does not close, this should not matter. If

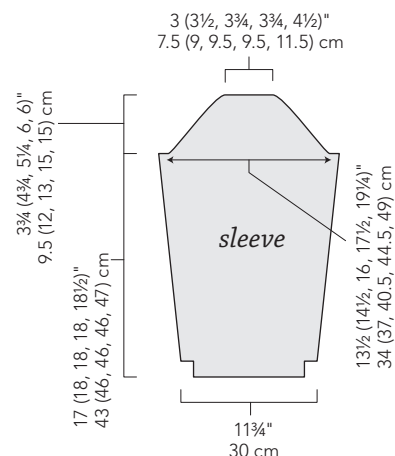
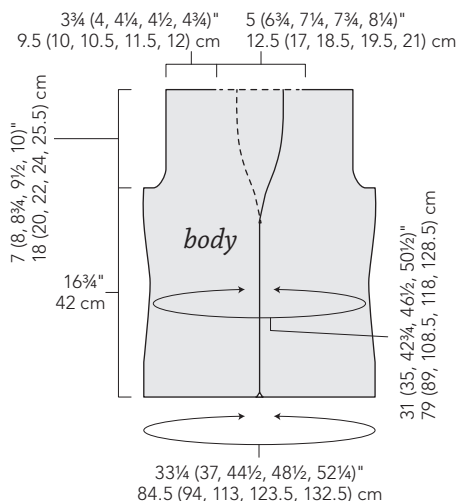

HD Harrisville Designs, Inc.



Yarns spun with care in Harrisville, NH

P.O. Box 806 • Harrisville, NH 03450
800-338-9415 • harrisville.com

Paca Peds Semi-Solid

*Kettle Dyed for
Picture Perfect Shawls*



Available with or
without a Coordinating
Heels & Toes Skein



#C815

Straker Classics
ALWAYS IN STYLE

view collection and find yarns shops near you at www.strakerclassics.com
wholesale orders at 508-990-0679 or pstraker@comcast.net

The Sanguine Gryphon Presents...

FILM NOIR



*Colorways and Patterns
debuting September 2011*
www.sanguinegryphon.com

you wish to belt the garment, you may want to work a size that overlaps in front—sizes 33¾", 44½", and 48½".

Stitch Guide

Backward Yarnover (BYO):

Bring yarn from back to front *over* right needle, then to back again between needles.

Yarnover (Yo):

Bring yarn from front to back *over* right needle.

Double-Knit Pattern: (odd number of sts)

Row 1: (RS) K1, *sl 1, k1; rep from * to end.

Row 2: (WS) Sl 1, *k1, sl 1; rep from * to end.

Rep Rows 1 and 2 for patt.

Double-Knit Mitered Corner: (worked over 14 sts)

First half:

Row 1: (RS) [K1, sl 1] 5 times, k1, turn.

Row 2: (WS) Sl 1 with yarn in back (wyb), BYO (see Stitch Guide), [k1, sl 1] 5 times.

Row 3: [K1, sl 1] 5 times, turn.

Row 4: Yo (see Stitch Guide), [k1, sl 1] 5 times.

Row 5: [K1, sl 1] 4 times, k1, turn.

Row 6: Sl 1 wyb, BYO, [k1, sl 1] 4 times.

Row 7: [K1, sl 1] 4 times, turn.

Row 8: Yo, [k1, sl 1] 4 times.

Row 9: [K1, sl 1] 3 times, k1, turn.

Row 10: Sl 1 wyb, BYO, [k1, sl 1] 3 times.

Row 11: [K1, sl 1] 3 times, turn.

Row 12: Yo, [k1, sl 1] 3 times.

Row 13: [K1, sl 1] 2 times, k1, turn.

Row 14: Sl 1 wyb, BYO, [k1, sl 1] 2 times.

Row 15: [K1, sl 1] 2 times, turn.

Row 16: Yo, [k1, sl 1] 2 times.

Row 17: K1, sl 1, k1, turn.

Row 18: Sl 1 wyb, BYO, k1, sl 1.

Row 19: K1, sl 1, k1, *next st on left needle is a yo, bring yarn to front, sl yo and foll st to right needle, with left needle tip, pass yo over st, take yarn to back, next st on left needle is a yo, k2tog (yo with foll knit st); rep from * 3 more times, next st

on left needle is a yo, bring yarn to front, sl yo and foll st to right needle, pass yo over st, k2.

Row 20: Sl 2, [k1, sl 1] 6 times.

Second half:

Row 21: K1, sl 1, k1, turn.

Row 22: Sl 1 wyb, BYO, k1, sl 1.

Row 23: K1, sl 1, k1, bring yarn to front, sl yo and foll st to right needle, pass yo over st, turn.

Row 24: Yo, [k1, sl 1] 2 times.

Row 25: [K1, sl 1] 2 times, take yarn to back, k2tog (yo with foll knit st), turn.

Row 26: Sl 1 wyb, BYO, [k1, sl 1] 2 times.

Row 27: [K1, sl 1] 2 times, k1, bring yarn to front, sl yo and foll st to right needle, pass yo over st, turn.

Row 28: Yo, [k1, sl 1] 3 times.

Row 29: [K1, sl 1] 3 times, take yarn to back, k2tog (yo with foll knit st), turn.

Row 30: Sl 1 wyb, BYO, [k1, sl 1] 3 times.

Row 31: [K1, sl 1] 3 times, k1, bring yarn to front, sl yo and foll st to right needle, pass yo over st, turn.

Row 32: Yo, [k1, sl 1] 4 times.

Row 33: [K1, sl 1] 4 times, take yarn to back, k2tog (yo with foll knit st), turn.

Row 34: Sl 1 wyb, BYO, [k1, sl 1] 4 times.

Row 35: [K1, sl 1] 4 times, k1, bring yarn to front, sl yo and foll st to right needle, pass yo over st, turn.

Row 36: Yo, [k1, sl 1] 5 times.

Row 37: [K1, sl 1] 5 times, take yarn to back, k2tog (yo with foll knit st), sl 1, k2.

BODY

Double-Knit Lower Band: Using the invisible-provisional method (see Glossary), MC and larger needle, CO 14 sts.

Row 1: (RS) [K1, sl 1] 6 times, k2.

Row 2: Sl 2, [k1, sl 1] 6 times.

Work 37-row double-knit mitered corner (see Stitch Guide), ending with a RS row.

Next row: (WS) Sl 2, [k1, sl 1] 6 times.

Place removable m in first st of row. Work even in patt over 14 sts for 128 (144, 176, 192, 208) more rows—band measures about 30¾ (34, 41½, 45½, 49¾)" across top selvedge edge. Work 37-row mitered corner. Work 1 WS row. **Next row:** (RS) Work across 14 band sts, cont with MC, using a 1-st selvedge, pick up and knit 129 (145, 177, 193, 209) sts along top selvedge of band (1 st for every row), then with RS still facing, unzip provisional CO and slip live sts to other end of larger needle, with tip pointing toward body. Work across these 14 band sts in band patt (the patt won't line up perfectly, since you're working in the opposite direction now)—



- MC: k on RS; p on WS
- CC1: k on RS; p on WS
- CC2: k on RS; p on WS
- pattern repeat

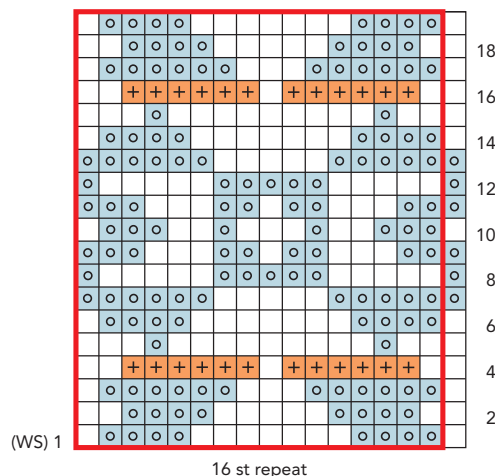



Misti Alpaca
Softest Yarn Ever

Tonos Worsted
50% Baby Alpaca 50% Merino
Lattice Cable Delight Cardigan

Pattern Download at: www.mistialpaca.com

New! Deluxe Needle Felting Kit



Deluxe Needle Felting Kit, includes:
12.5" x 12.5" foam pad,
12 colors of assorted roving,
felting needles and intro to needle felting instructions.

Fiber Trends®

HAND KNIT DESIGNS

EXCLUSIVE distributor of
Big Sky Knitting Designs

www.fibertrends.com
Contact us for wholesale information
888.733-5991 or email jackie@fibertrends.com

Glimåkra Swifts



2 year warranty
manufactured in Sweden for 80+ years

2 sizes:
- Large 100"
- Regular 72" circumference

Forest Stewardship Council wood

\$75 Large
\$69 Regular

Glimakra USA LLC
www.glimakraUSA.com
1-866-890-7314



Knit Whimsy

Kathryn Alexander Designs kits available from
carolina HOMESPUN
carolinahomespun.com
800-450-SPUN(7786)
1% for PEACE

157 (173, 205, 221, 237) sts total on needle. **Next row:** (WS) Working band in double-knit patt with MC and joining to center section of body with intarsia twist, work as foll: Work 12 band sts in patt, p2tog (last 2 band sts), join CC1 and CC2 and work Row 1 of chart over picked-up sts, work intarsia twist, with MC from band, p2tog (first 2 band sts), work in patt to end—155 (171, 203, 219, 235) sts rem; 13 sts for each band. Work through Row 3 of chart. **Band short-rows:** (RS) Work 13 band sts in patt, turn; (WS) work intarsia twist with both CC's, work 13 band sts in patt to end, turn; (RS) Work 1 row in patt across all sts, turn; (WS) Work 13 band sts in patt, turn; (RS) work intarsia twist, work to end, turn. Cont in patt and on every 4th row of body, work short-rows over bands in this manner. Work through Row 19 of chart, ending with a WS row. **Next row:** (RS) Work band sts in patt (including short-rows), join new strand of MC and, using smaller needle (see Notes), k33 (33, 49, 49, 49), place marker (pm) for side, k63 (79, 79, 95, 111), pm for side, k33 (33, 49, 49, 49), join MC strands with intarsia twist, work band sts with larger needle (including short-rows). **Dec row:** (WS) Work band sts; then with smaller needle, purl and dec 7 sts evenly over body sts (2 sts on each front and 3 sts on back); with larger needle, work band sts—148 (164, 196, 212, 228) sts rem; 122 (138, 170, 186, 202) sts for body, plus bands. Working bands on larger needle, cont short-rows every 4 rows, and working body sts with smaller needle, twisting MC strands at bands, work even for 4 more rows. **Shape back waist: Dec row:** (RS) Work to first side m, sl m, k2tog, work to 2 sts before next side m, ssk, sl m, work to end—2 sts dec'd on back. Rep Dec row every 4th row 2 more times—116 (132, 164, 180, 196) sts rem for body; 54 (70, 70, 86, 102) sts for back and 31 (31, 47, 47, 47) sts for each front. Work 3 rows even. **Inc row:** (RS) Work in patt to m, sl m, M1, work in patt to next m, M1, sl m, work in patt to end—2 sts inc'd on back. Rep Inc row every 4th row 2 more times—122 (138, 170, 186, 202) sts for body. Work 2 rows even, ending with a RS row. **Inc for colorwork:** (WS) Work band sts, purl and inc 7 sts evenly over body sts (2 sts for each front and 3 sts for back), work band sts—129 (145, 177, 193, 209) sts for body. Work 1 RS row even. Read the foll section carefully before proceeding; neck and collar shaping beg

on Row 4 of colorwork, and short-rows cont on bands (and collar) as sts are added for collar.

Second colorwork section: Change to larger needles on body sts. **Next row:** (WS) Work band sts in patt, join CC1 and CC2 and work Row 1 of chart to 2nd band, work band sts in patt. Work in patt through Row 19 of chart and **at the same time**, beg on Row 4 of chart, **shape neck:** (RS) Work band sts in patt, ssk, work in patt to 2 sts before band, k2tog, work band sts in patt—2 sts dec'd; 1 at each neck edge. Rep neck decs every 2nd (4th, 2nd, 2nd, 4th) row 12 (8, 25, 18, 11) more times. **At the same time**, after working 2 rows above beg of neck shaping, beg shaping collar: (RS; band short-row) Work 2 band sts in patt, yo, work in patt to end of band, turn, work intarsia twist, work in patt to end, working new st into patt; turn, work 2 band sts in patt, yo, work in patt to 2nd band, work in patt to last 2 band sts, yo, work 2 sts in patt, turn and work short-row, working new st into patt, turn, work in patt to last 2 band sts, yo, work last 2 sts. Work a yo at collar edge every RS row, including short-rows, in this manner, until there are 37 (37, 39, 41, 43) sts for each band/collar. Always work new sts into double-knit patt; the incs will not be as pretty on the RS, but remember that the shawl collar will fold back and the more attractive WS will show when the cardigan is worn. **At the same time**, when chart has been completed, change to MC and smaller needle for body sts again and work 1 RS row even. **Dec row:** (WS) Work in patt to side m while dec 1 st; work to next m while dec 5 sts evenly; work to 2nd band while dec 1 st. Work 2 more rows working collar incs, any band short-rows, any neck decs, and changing needle sizes between bands and body. Piece measures about 16 $\frac{3}{4}$ " from lower edge of band. **Divide for fronts and back:** (RS) *Work in patt to 2 (3, 3, 4, 6) sts before side m, BO 4 (6, 6, 8, 12) sts for underarm, removing m; rep from * once more, work in patt to end—54 (68, 68, 82, 94) sts rem for back. Place back and right front sts, including band, on holders or waste yarn.

LEFT FRONT

Working sts of left front only, cont body sts on smaller needle, band/collar on larger needle, cont collar incs, short-rows and neck shaping, and work armhole shaping as foll: Work 3 (3, 3, 1) row(s) in patt. **Shape armhole: Dec row:** (RS)

K2, ssk, work in patt to end—1 st dec'd at armhole. Rep last 4 (4, 4, 4, 2) rows 0 (2, 0, 5, 9) times more —1 (3, 1, 6, 10) sts dec'd at armhole. When all neck and armhole shaping is complete, 16 (17, 18, 19, 20) left-front body sts rem (not including band/collar sts). Work body sts even and cont until collar shaping is complete—53 (54, 57, 60, 63) sts total on needle; 37 (37, 39, 41, 43) sts for collar. Work all sts even in patt until armhole measures 7 (8, 8 $\frac{3}{4}$, 9 $\frac{1}{2}$, 10)", ending with a WS row. Place sts on holder.

RIGHT FRONT

With WS facing, join MC at underarm. Working body sts on smaller needle, band/collar on larger needle, and cont all established shaping, work 3 (3, 3, 3, 1) row(s) in patt. **Shape armhole: Dec row:** (RS) Work in patt to last 4 sts, k2tog, k2—1 st dec'd at armhole. Rep last 4 (4, 4, 4, 2) rows 0 (2, 0, 5, 9) times more. When all armhole and neck shaping is complete, 16 (17, 18, 19, 20) body sts rem. Complete as for left front.

BACK

With WS facing, join MC at underarm. Using smaller needle, work 3 (3, 3, 3, 1) row(s) even in St st. **Shape armhole: Dec row:** (RS) K2, ssk, knit to last 4 sts, k2tog, k2—2 sts dec'd. Rep last 4 (4, 4, 4, 2) rows 0 (2, 0, 5, 9) times more—52 (62, 66, 70, 74) sts rem. Work even in patt until armholes measures 7 (8, 8 $\frac{3}{4}$, 9 $\frac{1}{2}$, 10)", ending with a WS row. Leave sts on needle.

JOIN SHOULDERS

With RS tog, use three-needle BO (see Glossary) to join sts of each front shoulder to corresponding sts of back—20 (28, 30, 32, 34) sts rem for back neck.

COLLAR

Right-front collar: With RS facing, join MC to collar and, working with larger needle, *work to last collar st, ssk (last collar st and next st from back neck); turn and work 1 WS row to end of collar. Rep from * until 10 (14, 15, 16, 17) back neck sts rem. Place collar sts on holder. **Left-front collar:** With RS facing, join MC to collar and work 1 RS row to end. **Next row:** (WS) *Work to last collar st, sl 1, sl 1 from back neck, turn; (RS) k2tog (1 back neck st with first collar st), work to end of collar; rep from * until all rem back neck sts are consumed. **Join collar:** You are going to graft the collar ends tog, grafting knit to knit



**HANDCRAFTED
HEXAGONAL NEEDLES**

*Style and Comfort
Made In Michigan*

**Experience The Difference
Knitting Made Easy**

WWW.INDIANLAKEARTISANS.COM
PHONE: 248.648.1218

**the mannings Handweaving School
& Supply Center**

1132 Green Ridge Road
PO Box 687
East Berlin, PA 17316
717-624-2223
orders - 1-800-233-7166

We stock what every knitter needs: Knitting Books (over 400 titles), patterns from Fiber Trends, Sarah James, Lucy Neatby, etc., yarns from Brown Sheep, Koigu, Skacel, Plymouth, Noro, Opal, etc., knitting needles, tons of knitting gadgets and a large selection of the popular sock and scarf yarns. www.the-mannings.com

Treasure their art.
Value their health!
End the pain!

Help us provide women in Latin America with the ergonomic bench for backstrap weaving

www.synergoarts.org
(520) 400-1017

Synergo Arts
A nonprofit organization dedicated to helping artists and artisans benefit from ergonomics

Bouteloua
by Kennedy Berry
Hill Country Weavers

Prairie Bliss Collection

www.hillcountryweavers.com
512-707-7396
1701 South Congress Ave, Austin TX 78704

Protect and Organize Your Back Issues

Keep this valuable source of information fresh and available for reference. Slipcases are library quality. Constructed with heavy bookbinder's board and covered in a rich maroon leather grained material. A gold label with the *Knits* logo is included.

One - \$18 Three - \$45 Six - \$84
Add \$3.50 per slipcase for P&H - USA orders only

Send to: **TNC Enterprises Dept. IWK**
P.O. Box 2475
Warminster, PA 18974

Enclose name, address (*No P.O. boxes please*) and payment with your order.
PA residents add 6% sales tax. You can even call **215-674-8476** to order by phone.
Credit Card Orders: Visa, MC, AmEx accepted. Send name, number, exp. date and signature.

To Order Online: www.tncenterprises.net/iwk

on RS, then knit to knit on WS, so that the double-knit structure is maintained. With RS facing and beg at outer edge of collar, working over left-front collar end, use two separate needles as foll: *sl 1 knit st to one needle, sl next “purl” st to 2nd needle; rep from * to end—19 (19, 20, 21, 22) knit sts on front needle, 18 (18, 19, 20, 21) “purl” sts on back needle. Rep this process for right-front collar. With RS facing and working with needles holding 19 (19, 20, 21, 22) knit sts each, work Kitchener st (see Glossary) to join the RS of two ends. Turn work over; the “purl” sts are knit sts on WS. Use Kitchener st to join the collar ends on WS.

SLEEVES

With the provisional method, larger needle, and MC, CO 14 sts. Work in double-knit patt as for bottom band (do not work mitered corners) until there are 36 rows along one edge, ending with a WS row. Break yarn and place sts on holder.

Next row: (RS) With MC and larger needle, CO 1 st, then pick up and knit across long edge (using a 1-st selvage) as foll: *Pick up and knit 2 sts (1 for each st along edge), then pick up and knit 2 sts in next st (1 st in front loop, 1 st in back loop); rep from * to end, CO 1 st at end of row—50 sts. Working 1 edge st in St st in background color throughout and beg with WS Row 1, join CC1 and CC2 and work Rows 1–19 of chart. **Next row:** (RS) Change to smaller needle and knit 1 row with MC. **Next row:** (WS) Purl and dec 2 sts—48 sts rem. Work in St st with MC on smaller needle for rem of sleeve and shape sleeve as foll:

Size 33¼" only: Work 1½" even in St st, ending with a WS row.

All sizes: Inc 1 st each edge on foll RS row, then every 6th (6th, 2nd, 2nd, 2nd) row 3 (5, 8, 11, 15) more times—56 (60, 66, 72, 80) sts. Work even until sleeve measures 17 (18, 18, 18, 18½)" from bottom of band, ending with a WS row.

Shape cap: BO 3 (4, 4, 5, 7) sts at beg of next 2 rows. **Dec row:** (RS) K2, ssk, knit to last 4 sts, k2tog, k2—2 sts dec'd. Work 1 WS row even. Rep last 2 rows 6 (10, 10, 12, 12) more times. BO 0 (0, 2, 2, 3) sts at beg of foll 0 (0, 2, 2, 2) rows, then 4 sts at beg of foll 6 (4, 4, 4, 4) rows—12 (14, 16, 16, 18) sts rem. BO all sts.

FINISHING

Block all pieces. Sew sleeves into armholes and sew sleeve seams. Use Kitchener st to

graft the live sts of the sleeve cuffs tog, grafting RS knit sts, then WS knit sts as for collar. Weave in ends, tacking any holes at shoulder closed. Block seams.

Lisa Shroyer is editor of *Knitscene* magazine and author of *Knitting Plus: Mastering Fit + Plus-Size Style + 15 Projects* (Interweave, 2011). After many years of roaming the United States, including the beautiful Southwest, she has landed in the South.



CANYON CARDIGAN

Eunny Jang

Finished Size 36½ (40½, 44½, 48½, 52½, 56½)" chest circumference, buttoned. Cardigan shown measures 44½".

Yarn Tahki Yarns Jackson (100% wool; 131 yd [120 m]/3½ oz [100 g]): #002 mid-night (MC), 6 (7, 8, 9, 9, 10) balls; #001 white cap (CC), 2 balls.

Needles Size 13 (9 mm): 24" or longer circular (cir) and set of double-pointed (dpn). Spare cir needle in same size or smaller. Adjust needle size if necessary to

obtain the correct gauge.

Notions Markers (m); waste yarn for provisional CO; stitch holders; tapestry needle; six ¾" buttons.

Gauge 12 sts and 14 rnds = 4" in charted patt; 12 sts and 20 rnds = 4" in St st.

NOTES

- This sweater is worked in the round and steeked. Begin and end colors at center of steek.

BODY

Hem: With MC, cir needle, and using a provisional method (see Glossary), CO 103 (115, 127, 139, 151, 163) sts. Do not join. **Set-up row:** (RS) K24 (27, 30, 33, 36, 39) for right front, place marker (pm), k55 (61, 67, 73, 79, 85) for back, pm, k24 (27, 30, 33, 36, 39) for left front. Work in St st until piece measures 2" from CO, ending with a WS row. Purl 1 RS row for turning ridge. With RS facing, pm, CO 5 sts for steek, pm, and join in the rnd—108 (120, 132, 144, 156, 168) sts; rnd beg at end of steek. Work in St st until piece measures 2" from turning ridge. Remove provisional CO and place sts onto spare needle. Fold hem to WS along turning ridge. **Joining rnd for hem:** *Knit 1 st from front needle tog with 1 st from back needle; rep from * to last 5 sts, k5. Work in St st until piece measures 8" from turning ridge. **Colorwork:** Join CC and knit 1 rnd. With MC, knit 1 rnd. Beg and ending as indicated for your size, work Rows 1–37 of Snowflake chart over 103 (115, 127, 139, 151, 163) sts, working steek sts as foll: [k1 with MC, k1 with CC] 2 times, k1

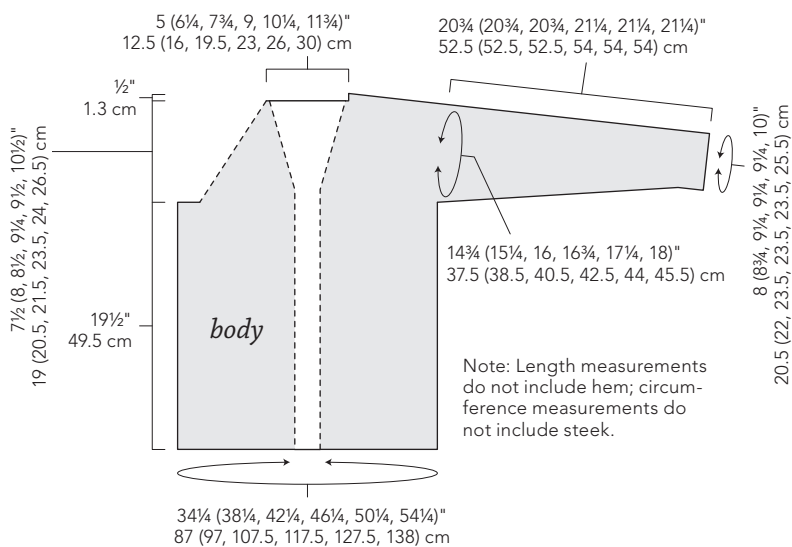

BIGGAN DESIGN



64 BRILLIANT COLOURS

100% Australian Merino First Cross
Pure New Wool in 8ply/DK and 4ply

So soft you can wear it on your skin!
Machine washable on 300 C wool or gentle cycle

FREE POSTAGE WORLDWIDE
for orders over Au\$200
Telephone, Mail & Internet Orders

www.biggandesign.com

HEAD OFFICE: PO Box 798, Kenmore, QLD 4069, Australia
Tel: +61 (0)7 3378 4453

HM29-05_12



The Perfect Tools to Craft Perfection
signatureneedlearts.com



Intwined Pattern Studio

Chart Design Software

User-friendly—just bring
your creativity.

Share and publish your
own designs anywhere—
blogs, books and friends!

*“Creating a chart is
simplicity itself.”*

The Knitter



JUST
\$44

See demo videos on our website:
www.IntwinedStudio.com

Use code KTXB for \$4 off

Introducing sock yarn with built-in climate control.



55% superwash Merino, 15% nylon and 30% Outlast®,
a fiber technology that continuously interacts with a body's microclimate
to moderate temperature from being too hot or too cold.



LORNA'S LACES
HAND-DYED YARNS

We make pretty string.

www.lornalaces.net/outlast

Snowflake

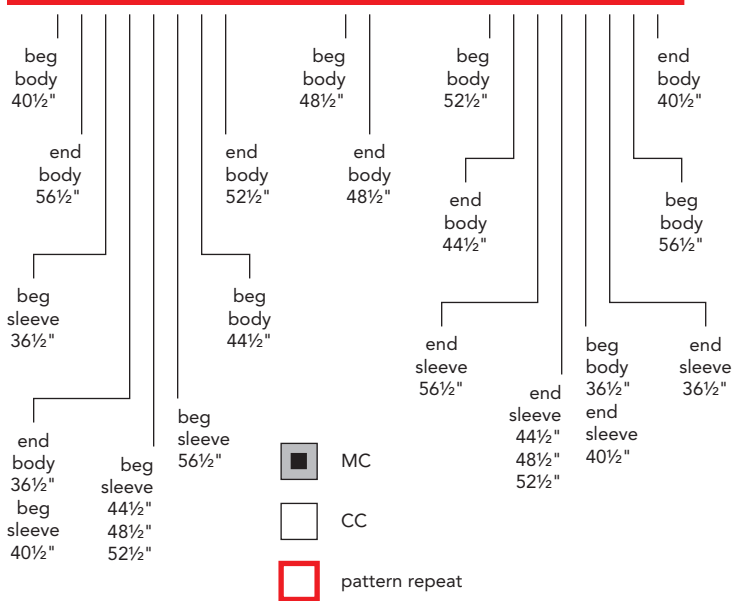
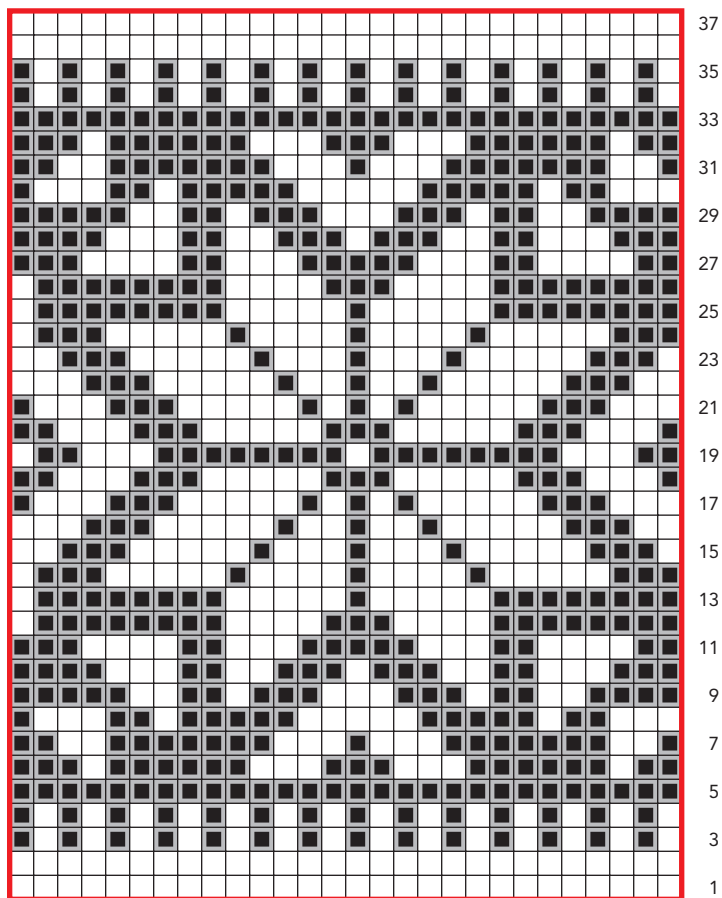

with MC. **Divide fronts and back:** With MC, k19 (22, 25, 28, 31, 34), k10 and place these 10 sts on holder (removing m), k45 (51, 57, 63, 69, 75), k10 and place these 10 sts on holder (removing m), knit to end of rnd. Set aside.

SLEEVES

With MC, dpn, and using a provisional method, CO 24 (26, 28, 28, 28, 30) sts. Pm and join in the rnd. **Set-up rnd:** K23 (25, 27, 27, 27, 29), pm, p1 for faux seam. Work in patt as established until piece measures 2" from CO. Purl 1 rnd for turning ridge.



Work in St st with faux seam until piece measures 2" from turning ridge. Remove provisional CO and place sts onto spare needle. Fold hem to WS along turning ridge. **Joining rnd:** *Knit 1 st from front needle tog with 1 st from back needle; rep from * to last st, purl last st on front needle tog with last st on back needle. Work 1 rnd even. **Inc rnd:** M1R, knit to last st, M1L, p1—2 sts inc'd. Rep Inc rnd every 7th (7th, 7th, 6th, 5th, 5th) rnd 4 (4, 4, 5, 6, 6) more times—34 (36, 38, 40, 42, 44) sts. Work 6 rnds even. With CC, work 1 rnd. **Next rnd:** With MC, rep Inc rnd—36 (38, 40, 42, 44, 46) sts. Beg and ending as indicated for your size and maintaining faux seam, work Rows 1–37 of Snowflake chart over 35 (37, 39, 41, 43, 45) sts and, **at the same time**, rep Inc rnd on chart rows 8, 16, 24, and 32, working new sts into charted patt—44 (46, 48, 50, 52, 54) sts. **Set up for joining rnd:** With MC, k5 and place these 5 sts on holder, knit to last 6 sts, k6 and place these 6 sts on holder (removing m)—33 (35, 37, 39, 41, 43) sts rem. Place sts on holder.

YOKE

Joining rnd: With CC, k2tog, k17 (20, 23, 26, 29, 32) right-front sts, pm, k33 (35, 37, 39, 41, 43) held sleeve sts, pm, k45

knitting connection • website listings

to advertise here call Stephanie Griess at (877) 613-4630

PATTERNS

Gardiner Yarn Works

www.gardineryarnworks.com
orders@gardineryarnworks.com

Download fun, accurate patterns from designer Chrissy Gardiner and friends.

SHOPS/MAIL ORDER

Earth Guild

www.earthguild.com
(800) 327-8448

Yarns, needles, hooks, patterns, classes, books. Fiber supplies since 1970.

Woobee KnitShop

www.woobeeknitshop.com
(307) 760-2092

Products include Brown Sheep, Jean Greenhowe, Addi, and Skacel.

WEBSITES TO VISIT

Cotton Clouds

www.cottonclouds.com
(800) 322-7888

#1 source for quality natural fiber yarns, friendly service, affordable!

Knit Purl

www.knit-purl.com
(503) 227-2999
(866) 656-KNIT

Uncommon yarn for uncommon knitters. Your source for the extraordinary.

Lion Brand Yarn Company

www.lionbrand.com
(800) 258-YARN

Yarncrafting education, inspiration, and innovation. Famous for quality since 1878.

Peace, Love & Yarn

www.peaceloveyarn.com
(877) 795-9798

Unique and imaginative colors to spark your creativity.

Sweet Grass Wool

www.sweetgrasswool.com
(888) 222-1880

Domestic Targhee yarn and fiber, hand dyed and natural colors.

The Elegant Ewe

www.elegantewe.com
(603) 226-0066

The Yarn Barn

www.theyarnbarn.com
(203) 389-5117

A huge selection of unique yarns, fibers, buttons, patterns, and needlepoint.

YARNS

Berroco Yarns

www.berroco.com
info@berroco.com

Free patterns, yarn & shop finder, and free e-newsletter, KnitBits.

Gypsy Girl Creations

www.stonebarnfibers.com
(815) 968-1735

Lanaknits Designs

Hemp for Knitting

www.hempforknitting.com
(888) 301-0011

Exquisite hemp and hemp-blend yarns and designer patterns.

Paradise Fibers

www.paradisefibers.net
(888) 320-7746

Everything for Knitting, Spinning, Hand-weaving & Crochet. Same-day shipping!

Skacel Collection Inc.

www.skacelknitting.com
(800) 255-1278

Over 100 yarns, the entire Addi line, and much more!

Wolle's Yarn Creations

www.wollesyarncreations.etsy.com
Color-Changing Cotton Yarns
beautiful — creative — unique

Wool2Dye4

www.Wool2Dye4.com
Yarnie@Wool2Dye4.com

Exclusive line of undyed yarns for handdye artists.

Yarns International

www.yarnsinternational.com
(800) YARNS-2U

Pure 100 percent Shetland yarn in jumper and lace weight.

PERSONAL THREADS ROUTIQUE

Phone orders received before 12 noon are shipped the same day.

We Stock over 1,000 different yarns in a huge array of colors, including:

- Austermann
- Artful Yarns
- Artyarns
- Berroco/Lang
- Brown Sheep
- Classic Elite
- Colinette
- Crystal Palace
- Dale of Norway
- Debbie Bliss
- Dream In Color
- Filatura Di Crosa
- Fleece Artist / Handmaiden
- Frog Tree
- Grignasco
- Himalaya Yarn Co.
- Jade Sapphire
- K²C²
- Koigu Wool
- Lorna's Laces
- Malabrigo
- Mission Falls
- Mountain Colors
- Muench/GGH
- Nashua
- Noro
- O-Wool
- Plymouth
- Prism
- Qiyuik
- Reynolds
- Rowan/Ryc
- Schaefer
- Shokay
- Sirdar
- Skacel
- Stonehedge Fibers
- Tahki/Stacy Charles
- Tilly Tomas
- Trendsetter

To Order: 1-800-306-7733

PERSONAL THREADS ROUTIQUE

Knitting • Needlepoint • Weaving • Quilting

Quilting Fabrics: Kaffe Fassett-Martha Negley-Carla Miller-Phillip Jacobs

8600 Cass Street • Omaha, Nebraska 68114

Fax: 402-391-0039 • e-mail: sales@personalthreads.com

www.personalthreads.com



2011 J Doric in Classic Worsted

organic
it just feels right

o~wool™

http://www.o-wool.com - 888.673.0260
info@funneywoolcompany.com

(51, 57, 63, 69, 75) back sts, pm, k33 (35, 37, 39, 41, 43) held sleeve sts, pm, k17 (20, 23, 26, 29, 32) left-front sts, ssk, work 5 steek sts—152 (168, 184, 200, 216, 232) sts total. Break CC. With MC, work 4 rnds in St st. **Neck dec rnd:** Ssk, work to 2 sts before steek, k2tog, work steek sts—2 sts dec'd. Rep neck dec rnd every 5th (5th, 5th, 4th, 3rd, 3rd) rnd 0 (2, 4, 6, 8, 10) more times, then every 9th (9th, 9th, 8th, 7th, 7th) rnd once. **At the same time,** on 9th (9th, 9th, 11th, 11th, 13th) rnd after last CC rnd, shape raglan as foll: *Work to 2 sts before m, k2tog, sl m, ssk; rep from * 3 more times, work to end—8 sts dec'd. Rep last rnd every other rnd 14 (15, 16, 17, 18, 19) more times—28 (32, 36, 40, 44, 48) sts rem: 1 st for each front, 15 (19, 23, 27, 31, 35) sts for back, 3 sts for each sleeve, 5 sts for steek. BO all sts.

FINISHING

Weave in loose ends. Block to measurements. **Cut steek:** Use a wide, short zigzag stitch to machine-stitch steek between first and 2nd steek sts and between 4th and 5th steek sts. Cut carefully up center of 3rd steek st. **Band:** With MC, cir needle, and RS facing, beg at lower right front edge, pick up and knit 82 (84, 86, 89, 90, 94) sts up right front to back neck, 15 (19, 23, 27, 31, 35) sts across back neck, and 82 (84, 86, 89, 90, 94) sts down left front to lower edge—179 (187, 195, 205, 211, 223) sts total. Do not join. Work 4 rows in St st. **Buttonhole row:** (WS) P3, work 3-st one-row buttonhole (see Glossary), *p6, work 3-st one-row buttonhole; rep from * 4 more times, purl to end—6 buttonholes. Work 1 row in St st. Shape band using short-rows (see Glossary) as foll:

Short-row 1: (WS) P115 (122, 129, 138, 144, 154), wrap next st, turn.

Short-row 2: (RS) K51 (57, 63, 71, 77, 85), wrap next st, turn.

Short-row 3: P33 (38, 43, 49, 54, 60), wrap next st, turn.

Short-row 4: K15 (19, 23, 27, 31, 35), wrap next st, turn.

Next row: (WS) Work to end, working wraps tog with wrapped sts as you come to them. **Next row:** Work to end, working rem wraps tog with wrapped sts. **Next row:** Knit 1 row for turning ridge. Work 1 RS row in St st. Rep Short-rows 1–4.

Next row: (WS) Work to end, working wraps tog with wrapped sts as you come to them. **Next row:** Work to end, working rem wraps tog with wrapped sts. Rep

buttonhole row. Work 4 rows in St st. Cut yarn, leaving a long tail. Sew live sts to WS of garment. Sew buttons to right front opposite buttonholes. With CC threaded on a tapestry needle, join underarms using Kitchener st (see Glossary).

Eunny Jang knits, sews, and edits *Interweave Knits* in Northern Colorado.



BORDER SOCKS

Mary Jane Mucklestone



Finished Size 7½ (9, 10½)" foot circumference and 8½ (10, 11½)" long from back of heel to tip of toe. Foot length is adjustable. To fit men's small (medium, large). Socks shown in medium size.

Yarn Plymouth Yarn Alpaca Prima (100% alpaca; 363 yd [333 m]/3½ oz [100 g]): #66 denim blue (MC), #3181 marled white (CC1), and #302 brown (CC2), 1 skein each.

Needles Sizes 2 (2.75 mm) and 3 (3.25 mm): set of five double-pointed (dpn). Adjust needle size if necessary to obtain the correct gauge.

Notions Markers (m); tapestry needle.

Gauge 32 sts and 28 rnds = 4" in charted Fair Isle patt on larger needles; 32 sts and 36 rnds = 4" in wide wale rib on smaller needles.

NOTES

- The six-stitch pattern repeats make it easy to customize the fit of this sock.

Stitch Guide

Wide Wale Rib (multiple of 6 sts)

CUSTOMIZE IT

Work this sock in colors as bright or as subdued as you like—just remember to use a dark shade, a light shade, and a shade in between.





Ann Budd + Socks

A MATCH MADE IN HEAVEN



Sock Knitting Master Class

Innovative Techniques
+ Patterns from Top Designers

184 pages

ISBN: 978-1-59668-312-9

\$26.95

WITH THE MOST EXCITING SOCK DESIGNERS TODAY

*Cookie A Kathryn Alexander Véronik Avery Cat Bordhi
Nancy Bush Evelyn A. Clark Chrissy Gardiner Priscilla Gibson-
Roberts Anne Hanson Eunny Jang Melissa Morgan-Oakes
Deborah Newton Meg Swansen Anna Zilboorg*

 **INTERWEAVE**
interweavestore.com

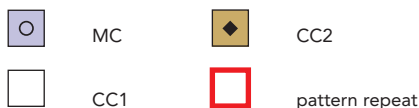
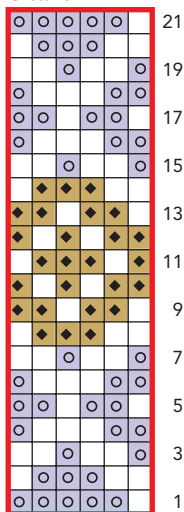
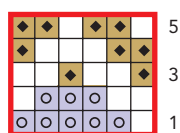

Chart A



6 st repeat

Chart B



6 st repeat

Rnd 1: *P1, k5; rep from * to end.
Rep Rnd 1 for patt.

SOCK

Cuff: With MC and smaller needles, CO 60 (72, 84) sts—15 (18, 21) sts on each needle. Place marker (pm) and join in the rnd. Work in k1, p1 rib for 1". Change to larger needles. **Leg:** Work Rnds 1–21 of Chart A. Break CC1 and CC2 and cont with MC only. Change to smaller needles. Knit 2 rnds. Work wide wale rib (see Stitch Guide) until piece measures 7½" from CO.

Heel flap: **Next row:** K15 (18, 21), turn.

Next row: P30 (36, 42) for heel flap, turn. Leave rem 30 (36, 42) instep sts on needles and work heel flap back and forth over 30 (36, 42) sts.

Row 1: (RS) *Sl 1, k1; rep from * to end.

Row 2: (WS) Sl 1, p29 (35, 41).

Rep last 2 rows 14 (16, 18) more times for a total of 30 (34, 38) rows and 15 (17, 19) chain sts at edge of heel flap. **Turn heel:**

Row 1: (RS) Sl 1, k16 (19, 22), ssk, k1, turn.

Row 2: Sl 1, p5, p2tog, p1, turn.

Row 3: Sl 1, knit to 1 st before gap, ssk, k1, turn.

Row 4: Sl 1, purl to 1 st before gap, p2tog, p1, turn.

Rep last 2 rows 4 (5, 7) more times, ending with a WS row—18 (22, 24) sts rem.

Size Medium only:

Next row: (RS) Sl 1, k18, ssk, turn.

Next row: Sl 1, p18, p2tog, turn—20 sts rem.

All sizes:

Shape gusset:

Rnd 1: Needle 1: k18 (20, 24) heel sts and with same needle, pick up and knit 15 (18, 21) sts along edge of heel flap; Needle 2: work across 30 (36, 42) instep sts in wide wale rib as foll: k1, [k5, p1] 4 (5, 6) times, k5; Needle 3: pick up and knit 15 (18, 21) sts along other edge of heel flap, then k9 (10, 12) heel sts, ending at center of heel—78 (92, 108) sts total. Pm and resume working in the rnd.

Rnd 1: Needle 1: knit to last 3 sts, k2tog, k1; Needle 2: work in wide wale rib as established; Needle 3: k1, ssk, knit to end—2 gusset sts dec'd.

Rnd 2: Work even.

Rep last 2 rnds 8 (9, 11) more times—60 (72, 84) sts rem; 15 (18, 21) sts on Needles 1 and 3, and 30 (36, 42) sts on Needle 2. **Foot:** Work even until piece measures 6 (7, 7¾)" from back of heel, or 2½ (3, 3¾)" less than desired foot length.

Work Rnds 1–5 of Chart B once. Break MC and CC1 and cont with CC2 only. Knit 1 rnd. **Shape toe:**

Rnd 1: Needle 1: knit to last 3 sts, k2tog, k1; Needle 2: k1, ssk, knit to last 3 sts, k2tog, k1; Needle 3: k1, ssk, knit to end—4 sts dec'd.

Rnd 2: Knit.

Rep last 2 rnds 5 (8, 11) more times—36 sts rem. Rep Rnd 1 only 5 more times—16 sts rem. With Needle 3, knit sts from Needle 1—8 sts on each needle. Break yarn, leaving a 12" tail.

FINISHING

With tail threaded on a tapestry needle, graft toe using Kitchener st (see Glossary).

Weave in ends. Wash in a mild soap, press gently between towels to absorb excess moisture. Dry flat on sock blockers or press gently into shape.

Mary Jane Mucklestone loves colorful knitting of all kinds, especially the simple peerie patterns found in traditional Fair Isle knitting. In October 2011, Interweave will publish her book *200 Fair Isle Motifs: A Knitter's Directory*. She fled the big-city lifestyle years ago and now lives in rural Maine between a sugar shack and a sauerkraut shop.

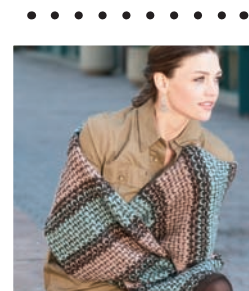

VARSITY STOLE

Annie Modesitt

Finished Size 16" wide and 72" long.

Yarn: Louet North America Eastport (70% USA alpaca, 30% merino; 150 yd [137 m]/2½ oz [75 g]): deep harbor black (A), aqua (B) and red sunrise (C), 3 balls each.

Needles Size 7 (4.5 mm).

Notions Tapestry needle.

Gauge 20 sts and 24 rows = 4" in caught float patt.



Knitting Takes a New Shape



meg SWANSEN
 DOMINO knitting
 annie MODESITT
 ENTRELAC knitting
 norah GAUGHAN
 quilt-inspired KNITS
 eunny JANG



See inside the issue

entreKNITS

knitting takes shape.

Download the latest revolutionary eMag *EntreKnits* today and take an interactive journey of form and function. *EntreKnits* explores unique tips and techniques for entrelac, quilt-inspired, and modular knitting with fun patterns, innovative and educational tutorials, inspirational videos, and up-close image galleries.

EntreKnits includes

- Stunning projects for all skill levels from topnotch knitters Eunny Jang, Vivian Høxbro, Grace Anna Farrow, Mercedes Tarasovich-Clark, and Norah Gaughan
- Informative articles on mathematical knitting, effortless entrelac, and even domino knitting in 3-D
- Interactive galleries of storage ideas for yarn and notions, yarn reviews, and a fun look at knitted swatches that mimic shapes in the everyday world.

Download your *EntreKnits* eMag today at Shop.KnittingDaily.com!!



NOTES

- Always work five-stitch edging with current main color of each row.
- Color A is used throughout; carry it from one color section to the next, where it will be either the main color (MC) or contrast color (CC) for next section. If Color B or C will not be used in next color section, cut and rejoin as needed, to avoid long floats at edge.

Stitch Guide

Sl2tog, k1, p2sso: Sl 2 sts as if to k2tog, knit next st, pass 2 slipped sts over knit st—2 sts dec'd.

Edge Pattern (over 5 sts at each edge)

Note: Sl sts pwise with yarn in front (wyf).

Row 1: (RS) K1, sl 1, k1, p2, work in patt to last 5 sts, p2, k1, sl 1, k1.

Row 2: (WS) Sl 1, k1, sl 1, k2, work in patt to last 5 sts, k2, sl 1, k1, sl 1.

Rep Rows 1 and 2 for patt.

Catch Float

On RS rows, slip float onto left needle and knit it tog with st on needle.

On WS rows, slip float onto left needle and purl it tog with st on needle.

Caught Float Pattern (multiple of 4 sts + 3)

Row 1: (RS) *Bring strand of CC to RS, with MC, k3, bring strand of CC to WS, with CC, k1; rep from * to last 3 sts, bring strand of CC to RS, with MC, k3.

Row 2: (WS) With MC, purl.

Row 3: With MC, *k1, catch float in next st (see Stitch Guide), k2; rep from * to last 3 sts, k1, catch float, k1.

Row 4: With MC, p1, *with CC, p1, bring strand of CC to RS, with MC, p3; rep from * to last 2 sts, with CC, p1, with MC, p1.

Row 5: With MC, knit.

Row 6: With MC, *k3, catch float in next st; rep from * to last 3 sts, k3.

Rows 7–11: Rep Rows 1–5.

Row 12: With MC, *p3, catch float in next st; rep from * to last 3 sts, p3.

STOLE

With A, using the crochet chain provisional method (see Glossary), CO 85 sts.

Edging:

Row 1: (RS) Work Row 1 of edge patt (see Stitch Guide) over 5 sts, knit to last 5 sts, work edge patt over rem 5 sts.

Row 2: Work Row 2 of edge patt over 5

sts, knit to last 5 sts, work edge patt over 5 sts.

Rows 3–6: Rep Rows 1 and 2 twice.

Body:

Keeping 5 sts each side in edge patt with MC of current row, work center 75 sts in caught float patt (see Stitch Guide) in the foll color sequence: Using A as MC and B as CC, work Rows 1–6 of patt 2 times.

*Using B as MC and A as CC, work Rows 7–12 of patt 3 times. Using A as MC and B as CC, work Rows 1–6 of patt once. Using A as MC and C as CC, work Rows 1–6 of patt once. Using C as MC and A as CC, work Rows 7–12 of patt 3 times. Using A as MC and C as CC, work Rows 1–6 of patt once. Using A as MC and B as CC, work Rows 1–6 of patt once. Rep from * (60 rows total) 6 more times, then using B as MC and A as CC, work Rows 7–12 of patt 3 times. Using A as MC and B as CC, work Rows 1–6 of patt 2 times.

Edging:

Work Rows 1–6 of edging with A.

I-cord BO:

Step 1: Align first 3 sts for working I-cord as foll: Sl left needle through back loop of first 2 sts and sl sts off needle. Turn left needle and return these 2 sts to right needle in reverse order (i.e., what was the first st is now the second st, and vice versa). Join A.

Step 2 (first corner): *K3, sl these 3 sts back onto left needle, draw the yarn firmly behind the sts; rep from * once more.

Step 3: *K3, ssk, sl these 4 sts back onto left needle; rep from * until 5 sts rem.

Step 4: K1, sl2tog, k1, p2sso (see Stitch Guide), k1, sl 3 sts back onto left needle.

Step 5: Sl2tog, k1, p2sso. Fasten off last st.

Remove provisional CO chain and place live sts on needle. Work I-cord BO across.

FINISHING

Steam block piece to measurements. Weave in ends.

Annie Modesitt is a designer based in St. Paul, Minnesota. She loves all types of fiber, biking, snow, and her family—though not in that order. She has taught all over the United States and at a few places in Europe, too. She's lucky.

**KELMSCOTT THROW**

Ann McDonald Kelly

Finished Size 47¼" wide × 65" long.

Yarn Harrisville Designs New England Highland (100% wool; 200 yd [183 m]/3½ oz [100 g]): #56 jade (MC), 10 skeins; #44 white (CC), 9 skeins.

Needles Size 7 (4.5 mm): 60" circular (cir). Adjust needle size if necessary to obtain the correct gauge.

Notions Tapestry needle; 5" piece of cardboard for making tassel.

Gauge 14 sts and 22 rows = 4" in patt.

NOTES

- When following the Damask chart, you are working both sides of the throw simultaneously. The side with MC as the background and CC as the motif color is Side A, and the side with CC as the background and MC as the motif color is Side B. Each chart square represents two stitches, one knit stitch from one side and one purl stitch from the opposite side. When you are on Side A, knit the background stitches with MC (for Side A) and purl the background stitches with CC (for Side B). When you come to the motif stitches, you knit with CC and purl with MC. On Side B, knit the background stitches with CC (for Side B) and purl with MC (for Side A). Knit the motif stitches with MC and purl with CC. (The chart only shows Side A.)
- Twist the working yarn around the non-working yarn at the beginning of each row in order to avoid having the two faces of your work separate at the sides.
- Work 62-stitch repeat of chart 2 times.

BLANKET

With MC and using the long-tail method, CO 330 sts (for Side A and Side B). Do not join.

Set-up Row 1: (Side A facing) Join CC.

*Bring both yarns to back and k1 with MC, bring both yarns to front and p1 with



Knitting Daily TV Series 700 is available on DVD!

Join the editor of *Interweave Knits* magazine and host Eunny Jang with experts Shay Pendray and Kristin Omdahl on *Series 700 of Knitting Daily TV*! You'll learn all-around fiber knowledge, explore in-depth techniques, and meet well-known designers.



With series 700 you'll:

- Improve your knitting and crochet skills
- Learn to knit and crochet one-of-a-kind designs of all sizes
- Move beyond basic knitting and purling with steeking, intarsia, lace knitting, felting, and even sideways knitting
- Join the crochet-along for the Chain Reaction Afghan Project
- Discover quick tips that answer common knitting questions
- Learn how to properly measure yourself and others for knitwear that fits correctly
- Be fashion-forward with your knitwear this season with ruffles, plaids, and the latest yarns

PLUS!

This DVD set features two never-aired, in-depth knitting tutorials with Eunny Jang. Learn advanced techniques for Fair Isle and short-row knitting.



Buy the 4-DVD set featuring all 13 episodes of *Knitting Daily TV* from Series 700, now available at your local yarn shop or online at InterweaveStore.com.

Thanks to our Knitting Daily Sponsors:



Prism Arts, Inc., Tahki Stacy Charles, Inc., Trendsetter Yarns

CC; rep from * to end. Turn work, making sure to twist yarns before beg next row (see Notes).

Set-up Row 2: (Side B facing) *Bring both yarns to back and k1 with CC, bring both yarns to front and p1 with MC; rep from * to end.

Work Rows 1–44 of Damask chart 8 times (see Notes), ending with Side B facing. Work Set-up Rows 1 and 2 once more.

Next row: With MC only, *k1, p1; rep from * to end. With MC, BO as foll: Ssk, *ssk, pass first st over 2nd st; rep from * to end.

FINISHING

Weave in ends. Block piece. **Tassel:** (Make 4) Wrap MC 75 times around a 5" piece of cardboard. Secure one end of tassel by pulling an 18" length of MC through loops at top of cardboard and knotting it. (Extra yarn will be used to sew tassel to throw.) Cut loops at bottom of cardboard. Wrap another length of MC around top of tassel about 1" from tied end. Bury ends in center of tassel. Trim bottom of tassel to make it even. Sew one tassel to each corner of throw.

Ann McDonald Kelly learned to knit from her Danish mother at age five, and she hasn't stopped knitting yet! When not knitting her fingers to the bone, she can be found stocking shelves and teaching classes at the Black Sheep Yarn Shop in Cockeysville, Maryland.

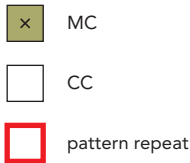

Damask

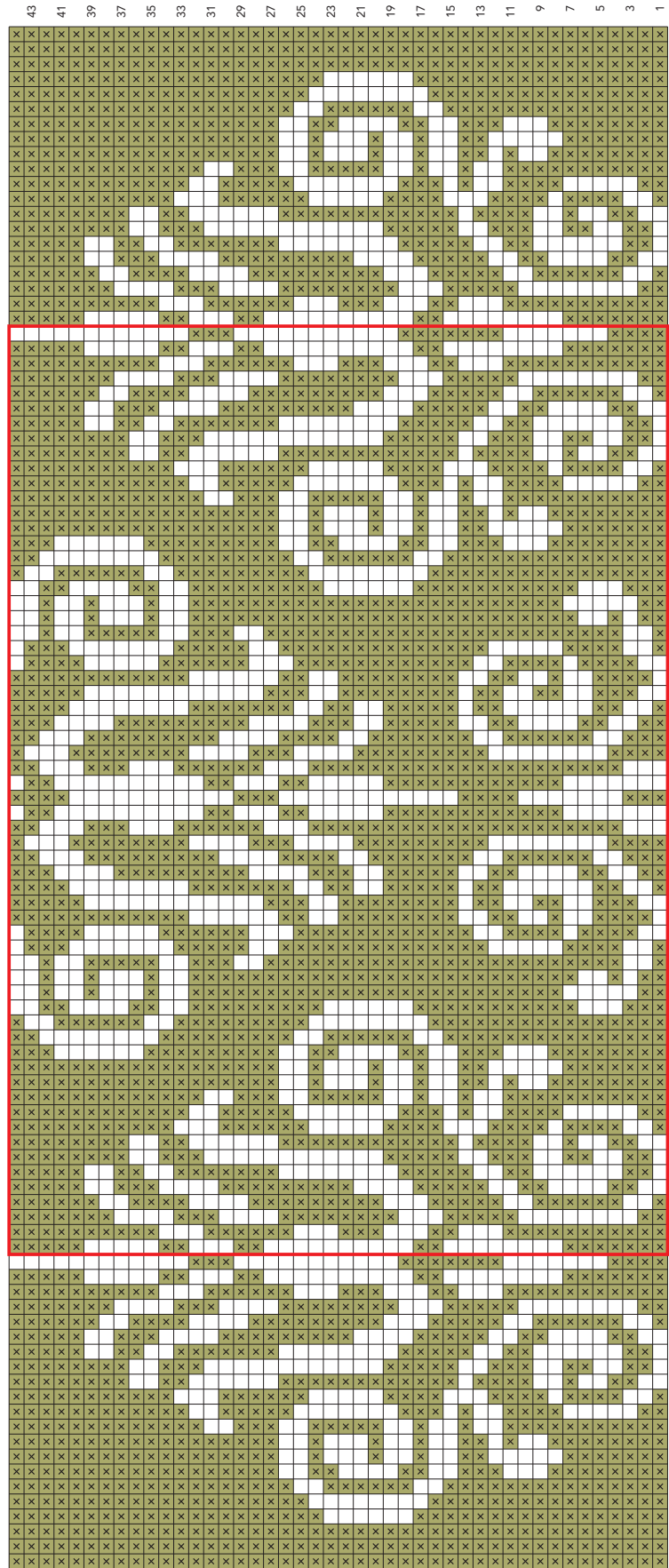

62 st repeat



**Coming soon
to the knitting bag near you**

Start to Finish Before You Start:
How to plan and knit your sweater
(with Eastern European accent)
so that finishing is not a pain...
by Faina Letoutchaia



Book+DVD - you can read and watch and switch from one to another

Knitting knowledge series <http://2plyproductions.com/>

★ **DESIGNER SEMINARS** ★

AYLIN'S WOOLGATHERER
1-800-775-WOOL

Great selection of exquisite yarns from all over the world. Hundreds of buttons. Area's largest collection of pattern books. Rosewood & Addi.
www.aylins-wool.com • e-mail aylin@aylins-wool.com

AYLIN'S
7245 Arlington Blvd., Falls Church, VA 22042
703.573.1900

★ **EXPERT FINISHING** ★

CLASSES



Knit with love.
Knit for the cure.
Knit Denise.

\$150,000
donated
to breast cancer
research...so far!
Thank you!

Denise

knitdenise.com
888-831-8042



GREEN MOUNTAIN SPINNERY

AMERICAN GROWN YARN SINCE 1981

800.321.9665 • WWW.SPINNERY.COM



KNIT provocatively
distinctive jewelry from wire

knit kit Jewelry
...just add needles!

KnitKitJewelry.com



basketry
book arts
dyeing
knitting
papermaking
spinning
surface design
textile arts
weaving

the weaving works

4717 Brooklyn Ave NE
Seattle, WA 98105

supplies / classes / books

web site: www.weavingworks.com • e-mail: weavingworks@speakeasy.net
orders: 1-888-524-1221 info: (206) 524-1221 fax: (206) 524-0250

What's Missing? Your Ad. . .



Contact Julie Macdonald at (970)-613-4612
or jmacdonald@interweave.com
for more information



the yarn lounge™
classes, accessories, and cool natural fibers

3003 west cary street | richmond, virginia
804 340 2880 | theyarnlounge.com

it's hip to knit

ABBREVIATIONS

beg	beginning; begin; begins
bet	between
BO	bind off
CC	contrasting color
cm	centimeter(s)
cn	cable needle
CO	cast on
cont	continue(s); continuing
dec(s)	decrease(s); decreasing
dpn	double-pointed needle(s)
foll	following; follows
g	gram(s)
inc	increase(s); increasing
k	knit
k1f&b	knit into front and back of same st
k2tog	knit two stitches together
knwise	knitwise
LC	left cross
m(s)	marker(s)
MC	main color
mm	millimeter(s)
M1	make one (increase)
M1R (L)	make one right (left)
p	purl
p1f&b	purl into front and back of same st
p2tog	purl two stitches together
patt(s)	pattern(s)
pm	place marker
pssso	pass slipped stitch over
p2sso	pass two slipped stitches over
pwise	purlwise
RC	right cross
rem	remain(s); remaining
rep	repeat; repeating
rev St st	reverse stockinette stitch
rib	ribbing
rnd(s)	round(s)
RS	right side
rev sc	reverse single crochet
sc	single crochet
sk	skip
sl	slip
sl st	slip stitch (sl 1 st pwise unless otherwise indicated)
ssk	slip 1 kwise, slip 1 kwise, k2 sl sts tog tbl (decrease)
ssp	slip 1 kwise, slip 1 kwise, p2 sl sts tog tbl (decrease)
st(s)	stitch(es)
St st	stockinette stitch
tbl	through back loop
tog	together
WS	wrong side
wyb	with yarn in back
wyf	with yarn in front
yo	yarn over
*	repeat starting point (i.e., repeat from *)
**	repeat all instructions between asterisks
()	alternate measurements and/or instructions
[]	instructions that are to be worked as a group a specified number of times

2 (3, 4, 5) Stitch One-Row Buttonhole

Work to where you want the buttonhole to begin, bring yarn to front, slip one purlwise, bring yarn to back (Figure 1). *Slip one purlwise, pass first slipped stitch over second; repeat from * one (two, three, four) more time(s). Place last stitch back on left needle (Figure 2), turn. Cast-on three (four, five, six) stitches as follows: *Insert right needle between the first and second stitches on left needle, draw up a loop, and place it on the left needle (Figure 3); repeat from * two (three, four, five) more times, turn. Bring yarn to back, slip first stitch of left needle onto right needle and pass last cast-on stitch over it (Figure 4), work to end of row.



Figure 1



Figure 2



Figure 3



Figure 4

Cable Cast-On

Begin with a slipknot and one knitted cast-on stitch if there are no established stitches. Insert right needle between first two stitches on left needle (Figure 1). Wrap yarn as if to knit. Draw yarn through to complete stitch (Figure 2) and slip this new stitch to left needle as shown (Figure 3).



Figure 1



Figure 2



Figure 3

Crochet Chain (ch)



Make a slipknot on hook. Yarn over hook and draw it through loop of slipknot. Repeat, drawing yarn through the last loop formed.

Crochet Chain (Provisional) Cast-On

With waste yarn and crochet hook, make a loose chain of about four stitches more than you need to cast on. With needle, working yarn, and beginning two stitches from end of chain, pick up and knit one stitch through the back loop of each crochet chain (Figure 1) for desired number of stitches.



Figure 1

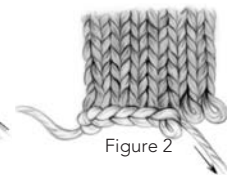

Figure 2

Work the piece as desired, and when you're ready to work in the opposite direction, pull out the crochet chain to expose live stitches (Figure 2).



I-Cord

With double-pointed needle, cast on desired number of stitches. *Without turning the needle, slide the stitches to other end of the needle, pull the yarn around the back, and knit the stitches as usual; repeat from * for desired length.

OOPS!

For corrections to issues of *Interweave Knits*, visit interweaveknits.com/corrections.

Invisible (Provisional) Cast-On

Place a loose slipknot on needle held in your right hand. Hold waste yarn next to slipknot and around left thumb; hold working yarn over left index finger.



Figure 1

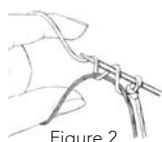

Figure 2

*Bring needle forward under waste yarn, over working yarn, grab a loop of working yarn (Figure 1), then bring needle to the front, over both yarns, and grab a second loop (Figure 2). Repeat from *. When you're ready to work in the opposite direction, pick out waste yarn to expose live stitches.

Kitchener Stitch

Step 1: Bring threaded needle through front stitch as if to purl and leave stitch on needle.

Step 2: Bring threaded needle through back stitch as if to knit and leave stitch on needle.

Step 3: Bring threaded needle through first front stitch as if to knit and slip this stitch off needle. Bring threaded needle through next front stitch as if to purl and leave stitch on needle.

Step 4: Bring threaded needle through first back stitch as if to purl (as illustrated), slip this stitch off, bring needle through next back stitch as if to knit, leave this stitch on needle.

Repeat Steps 3 and 4 until no stitches remain on needles.

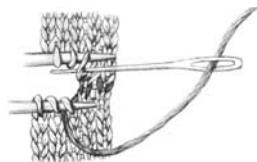

Right (RLI)



Knit into the back of stitch (in the "purl bump") in the row directly below the stitch on the left needle.

Purl (RLPI)

Purl into the stitch in the row directly below the stitch on the left needle.

Left (LLI)

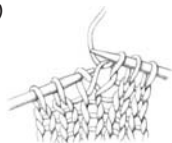

Insert left needle into back of the stitch below stitch just knitted.



Knit this stitch.

Purl (LLPI)

Purl into the stitch below the stitch just purled.



Short-Rows: Wrapping a Stitch



Figure 1



Figure 2

Work to turn point, slip next stitch purlwise to right needle. Bring yarn to front (Figure 1). Slip same stitch back to left needle (Figure 2). Turn work and bring yarn in position for next stitch, wrapping the stitch as you do so. *Note:* Hide wraps in a knit stitch when right side of piece is worked in a knit stitch. Leave wrap if the purl stitch shows on right side. Hide wraps as follows: *Knit stitch:* On right side, work to just before wrapped stitch. Insert right needle from front, under the wrap from bottom up, and then into wrapped stitch as usual. Knit them together, making sure new stitch comes out under wrap. *Purl stitch:* On wrong side, work to just before wrapped stitch. Insert right needle from back, under wrap from bottom up, and put on left needle. Purl them together.

Slip-Stitch Crochet (sl st)



Insert hook into stitch, yarn over hook and draw loop through stitch and loop on hook.

Three-Needle Bind-Off

Place stitches to be joined onto two separate needles. Hold them with right sides of knitting facing together. Insert a third needle into first stitch on each of the other two needles and knit them together as one stitch. *Knit next stitch on each needle the same way. Pass first stitch over second stitch. Repeat from * until one stitch remains on third needle. Cut yarn and pull tail through last stitch.



Find our full glossary online
@ knittingdaily.com.

REGISTER NOW FOR THE ULTIMATE LEARNING EXPERIENCE FOR PASSIONATE KNITTERS

INTERWEAVE Knitting Lab NOVEMBER 3-6, 2011

Marriott San Mateo,
(Near San Francisco, CA)

**NOW
AVAILABLE:**
Sunday Afternoon
Post-Event Classes
Followed by
Teatime with
Alice Starmore!

- Immersive instruction, in-depth seminars and lectures presented by icons of the knitting world
- Rarely-offered classes on regional, ethnic, and historical techniques
- A Knitter's Market featuring unique assortment of fiber and products
- A place to connect with knitters who share your passion

INSTRUCTORS INCLUDE: Cookie A.
Anne Berk • Cat Bordhi • Beth Brown-Reinsel
Ann Budd • Nancy Bush • Nilda Callañaupa • Donna Druchunas • Teva Durham • Karen Frisa • Kate Gagnon Osborn • Courtney Kelley • Vivian Hoxbro Stefanie Japel • Galina Khmeleva • Nancy Marchant Annie Modesitt • Mary Jane Mucklestone • Robin Hansen • Shirley Paden Clara Parkes • Carol Rhoades Gayle Roehm • Susan Strawn Meg Swansen • Amy Detjen Barbara Walker

Learn more and register now at:

www.InterweaveKnittingLab.com

2011 SPONSORS

 TAHKI STACY CHARLES, INC.

Classic Elite Yarns
[jimmy beans wool.com](http://jimmybeanswool.com)
Your Local Yarn Store...Online!



MANOS
DEL URUGUAY

TESS'
DESIGNER YARNS



skacel



Berroco Blackstone Tweed; (pages 98, 108) 65% wool, 25% superkid mohair, 10% angora; 130 yd [119 m]/1¼ oz [50 g]; 2-ply



Blue Moon Fiber Arts Gaea; (pages 54, 60) 100% certified organic merino wool; 305 yd [278 m]/8 oz [226 g]; 4-ply



Blue Moon Fiber Arts Silk Loops; (pages 54, 60) 54% kid mohair, 26% silk, 15% wool, 5% nylon; 390 yd [356 m]/8 oz [226 g]; novelty



Blue Sky Alpacas Bulky; (pages 26, 34) 50% alpaca, 50% wool; 45 yd [41 m]/3½ oz [100 g]; singles



Brown Sheep Company Lanaloft Worsted; (pages 56, 62) 100% wool; 160 yd [146 m]/3½ oz [100 g]; singles



Cascade Yarns 128; (pages 29, 40) 100% Peruvian wool; 128 yd [117 m]/3½ oz [100 g]; 2-ply



Cascade Yarns Eco+; (pages 102, 112) 100% natural Peruvian wool; 478 yd [437 m]/8 oz [250 g]; 2-ply



Classic Elite Yarns Ariosa; (pages 31, 46) 90% extrafine merino, 10% cashmere; 87 yd [80 m]/1¼ oz [50 g]; singles



Classic Elite Yarns Toboggan; (pages 32, 48) 70% merino, 30% superfine baby alpaca; 87 yd [80 m]/3½ oz [100 g]; 2-ply



Filatura di Crosa Superior (Tahki Stacy Charles); (pages 80, 92) 70% cashmere, 30% silk; 328 yd [300 m]/¾ oz [25 g]; novelty



Harrisville Designs New England Highland; (pages 107, 126) 100% pure wool; 200 yd [183 m]/3½ oz [100 g]; 2-ply



Imperial Yarn Bulky 2 Strand Pencil Roving; (pages 28, 37) 100% wool; 200 yd [182 m]/4 oz [113 g]; 2-ply



Jo Sharp Silkroad DK Tweed; (pages 58, 66) 85% wool, 10% silk, 5% cashmere; 147 yd [135 m]/1¼ oz [50 g]; 2-ply



Louet North America Eastport; (pages 106, 124) 70% USA alpaca, 30% merino; 150 yd [137 m]/2½ oz [75 g]; 3-ply



Malabrigo Lace; (pages 78, 86) 100% baby merino wool; 470 yd [430 m]/1¼ oz [50 g]; singles



Manos del Uruguay Serena (Fairmount Fibers); (pages 76, 82) 60% baby alpaca, 40% pima cotton; 170 yd [155 m]/1¼ oz [50 g]; 3-ply



Plymouth Yarn Alpaca Prima; (pages 104, 122) 100% alpaca; 363 yd [333 m]/3½ oz [100 g]; 3-ply



Rowan Big Wool (Westminster Fibers); (pages 33, 50) 100% merino wool; 87 yd [80 m]/3½ oz [100 g]; 3-ply



Schulana Cortina Nuvole (Skacel); (pages 30, 42) 70% pure merino wool, 30% nylon; 55 yd [50 m]/1¼ oz [50 g]; wrapped singles



Shibui Knits Silk Cloud; (pages 80, 96) 60% kid mohair, 40% silk; 330 yd [300 m]/¾ oz [25 g]; multi-ply



Tahki Yarns Jackson; (pages 104, 118) 100% wool; 131 yd [120 m]/3½ oz [100 g]; singles



Tahki Yarns Rio; (pages 100, 110) 50% alpaca, 35% merino wool, 15% silk; 87 yd [80 m]/1¼ oz [50 g]; singles

UNITED STATES YARN SOURCES

Berroco Inc.; (401) 769-1212; www.berroco.com.
Blue Moon Fiber Arts, (866) 802-9687; www.bluemoonfiberarts.com.
Blue Sky Alpacas, (763) 753-5815; www.blueskyalpacas.com.
Brown Sheep Co.; (800) 826-9136; www.brownsheep.com.
Cascade Yarns, www.cascadeyarns.com.
Classic Elite Yarns, (978) 453-2837; www.classicelityarns.com.
Fairmount Fibers/Manos del Uruguay, (888) 566-9970; www.fairmountfibers.com.
Harrisville Designs, (603) 827-3333; www.harrisville.com.
Imperial Stock Ranch/Imperial Yarn, (541) 395-2507; www.imperialyarn.com.

Malabrigo Yarn, (786) 866-6187; www.malabrigoyarn.com.
Plymouth Yarn Co.; (215) 788-0459; www.plymouthyarn.com.
Shibui Knits, (503) 595-5898; www.shibuiknits.com.
Skacel Collection/Schulana, (800) 255-1278; www.skacelknitting.com.
Tahki Stacy Charles Inc./Filatura di Crosa, (800) 338-YARN; www.tahkistacycharles.com.
Westminster Fibers/Rowan, www.westminsterfibers.com.

INTERNATIONAL SOURCES

Jo Sharp Hand Knitting Yarns, www.josharp.com.
Louet North America, www.louet.com.

❖ Contact these companies if you don't know of a local retailer or mail-order source for the yarns used in this issue. Yarns shown at 100% size.

ACCESSORIES



ACCESSORIES

ACCESSORIES



ACCESSORIES

ACCESSORIES



ACCESSORIES



ACCESSORIES



ARTISTS



BUTTONS



EVENTS



EVENTS



EVENTS



EVENTS

Southern Adirondack Fiber Tour
 SEPTEMBER 21-25
 Workshops
 Fiber Farm & Mill Visits
 888-203-8622
 Registration information:
www.washingtonnycounty.com



PATTERNS

H Harrisville Designs harrisville.com
 1-800-338-9415

VIVIAN HÖXBRO KITS



PATTERNS

OAT COUTURE
 natural knitting
 Delightful Patterns for the Handknitter & Crocheter
 Available at fine needlework shops.
 For a shop near you visit
www.oatcouture.com
 Box 967 Jacksonville, OR 97530
 GU434
 Manzanita Jacket



YARNS

ARNHILD'S KNITTING STUDIO
 AH2005
Rauma Yarn Distributor
 Find a retailer near you at:
www.arnhild.com
 Phone: 515-451-0584
 Email: arnhild@arnhild.com



INSTRUCTION

LUCY NEATBY
Make your stitches smile!
Three Cheers for Lucy!
 Check out our 3 newest knitting DVDs
 Knitting Venus 1
 The Brand New Knitter
 Knitting Venus 2
 Toll-Free 1-866-272-7796 | www.lucyneatby.com



PATTERNS

ILGA LEJA
Knitting Luxury, Knitting Opera
 902 425-2924
info@ilgaleja.com
www.ilgaleja.com



PATTERNS

KNITTING VINTAGE PATTERNS
 Vintage Knitting Crochet Patterns
 1900 to 1970s • Elegant to Mod
 If You Can Imagine It, We Have The Pattern!
KnittingVintagePatterns.com



YARNS

Blackberry Ridge Woolen Mill, LLC
 Wonderfully Warm Woolen Spun Yarns
 Merino wool grown in the USA and spun at our mill
www.blackberry-ridge.com
 3776 Forshaug Rd. Mt. Horeb, WI 53572
 (608) 437-3762



PATTERNS

Birch
Gardiner Yarn Works
<http://www.gardineryarnworks.com>



PATTERNS

knowknits
www.knowknits.com



YARNS

Visit the new AbstractFiber.com to see all our colors and fibers.
Abstract Fiber
 Hand-Painted Yarn & Fiber



YARNS

Creative Yarns
 ...where fiber fanatics gather
 Online Shopping:
www.creativeyarns.net
 relax. indulge. create.
 134 Speer Ave. Macon, GA 31204 478.746.5648
 Mon-Fri: 10am to 6pm
 Sat: 11am to 4pm
 Closed Sundays





knittingdaily WORKSHOP

EXPERT TEACHER & knitwear designer LILY CHIN shows you how to knit reversible cables & expand your knitwear options!



REVERSIBLE CABLES with Lily Chin

REVERSIBLE CABLE KNITTING is Lily's signature technique, and with this workshop video you'll soon master reversible cable knitting, *guaranteed*.

You'll learn

- General cable knitting techniques that will be your strong foundation for venturing into reversible knitwear.
- Reversible cabled knitting that is ribbed, identical front and back, not identical front and back but still reversible, variations on simple reversible techniques, bicolored brioche knitting, mock cable knitting, and much, much more!
- Finishing techniques and yarn options for making your reversible knitting stand out in a crowd, including ways to make your knitwear less bulky, I-cord trims, and more.



See more info on this DVD and watch a preview!

2-DVD Set \$34.95
Run time: 195 Minutes

 **INTERWEAVE**
interweavestore.com

Whether knitting REVERSIBLE CABLES with one color, two colors, or more—Lily's teaching style will have you confidently knitting reversible fashions in no time.

BEST OF HANDWOVEN eBooks

Top Ten Table Runners on Eight Shafts

Designing and Weaving with Blocks

A Baker's Dozen 13 Handwoven Bags

THESE DOWNLOADABLE COLLECTIONS AND MANY MORE ARE AVAILABLE NOW!

INTERWEAVE
interweavestore.com
866-949-1646

YARNS

EARTH GUILD

33 Haywood St
Asheville NC 28801
1-800-327-8448

**Tools • Books
• Materials •
for handcrafts**

Dragon Tale Yarns
www.earthguild.com

YARNS

Just Our Yarn

*luxurious handpainted yarns
and weaving kits*

www.justouryarn.com

YARNS

BFL in Fingering, DK and Aran
Warm, Rich and Soft

Miss Babs Hand Dyed Yarn
MISSBABS.COM

YARNS

The Warm Ewe
visit us! 2 hours from NYC

Fine Knitting Yarns, Beading & Needlepoint Supplies, & more!

31 Main Street, Chatham, NY
www.warmewe.com
(518) 392-2929

YARNS

habu textiles

paper
stainless steel
hand-tied ramie
pineapple, etc.

knit kits
fabrics

www.habutextiles.com 212-239-3546

YARNS

Lisa Souza
www.lisaknit.com The Luxury of Color

YARNS

pollika
KNITTING ACCESSORIES AND PRECIOUS YARNS

undyed yarns
shawl pins
european felt
buttons

www.pollika.com

YARNS

HAVE YOU TRIED IT?

HAVE YOU DYED IT?

Wool2Dye4.com

KNITS
the sweater workbook
2012 CALENDAR

Take a Sweater Workshop
with the 2012 *Interweave Knits* Wall Calendar

Buy one at your local yarn shop or online at the **knittingdailyshop**

ALABAMA

In the Making—Birmingham

www.shopinthemaking.com

Beautiful yarns & fabrics! Unique patterns and friendly staff! Next to Starbucks!

3108 Heights Village (877) 298-1309

ARIZONA

Fiber Factory—Mesa

www.fiberfactory.com

The Southwest's most complete yarn shop. Yarn, accessories, equipment, and classes.

216 W. Main St. (480) 969-4346

CALIFORNIA

K2TOG—Albany

www.k2togonline.com

A creative place where the community gathers to knit and crochet surrounded by fabulous yarns and awesome help.

1325 Solano Ave. (510) 526-9276

Unwind—Burbank

www.unwindyarn.com

Where yarn lovers in Southern California congregate—you're always welcome! Unparalleled selection, service, workshops, events.

818 N. Hollywood Wy. (818) 840-0800

Itza Knitterie—Glendale

www.itzaknitterie.com

Beautiful yarns, accessories, and classes for all levels. Sit and knit Thu evenings and Sat 1-4.

Call For New Address (818) 507-1813
(323) 440-7454

The Yarn Boutique—Lafayette

www.yarnboutique.us

Beautiful yarns; friendly, personal service; sensible prices. Located in La Fiesta Square near FedEx/Kinko's.

963-C Moraga Rd. (925) 283-7377

Uncommon Threads—Los Altos

www.uncommonthreadsyarn.com

Beautiful yarns from around the world.

293 State St. (650) 941-1815

Knit Culture Studio—Los Angeles

www.knitculture.com

Wide selection of unique and hand-dyed yarns, patterns, books, classes and crafting supplies. Amazing customer service!

8118 W 3rd St. (323) 655-6487

Piedmont Yarn & Apparel—Oakland

www.piedmontyarn.com

Local yarn, supplies, and classes for knitting, crochet, spinning, weaving, and felting. Friendly and helpful staff.

4171 Piedmont Ave., Ste.102 (510) 595-9595

Knit This, Purl That!—Pleasanton

www.yourknittingplace.com

Unique knitting shop in quaint downtown. Beautiful natural and blend yarns, supplies, and classes. yourknittingplace@comcast.net

205 A Main St. (925) 249-9276

Lake Tahoe Yarn Company—Truckee

www.laketahoeyarn.com

Serving the beautiful Truckee/Lake Tahoe area.

Yarns, patterns, accessories, classes. A shop to enjoy.
11008 Donner Pass Rd. (530) 587-1060

COLORADO

Knit One, Pearl Street—Bayfield

www.knitonepearlstreet.net

A full-service yarn shop nestled in the foothills of the Rocky Mountains of SW Colorado.

482 Pearl St. (970) 884-9008

Table Rock Llamas Fiber Arts Studio

www.tablerockllamas.com

Knitting, crochet, spinning, weaving, felting, and dyeing.

6520 Shoup Rd. (866) 495-7747

Bags By CAB Yarn Shoppe—Denver

www.bagsbycab.com

Lunch-hour classes—Crochet, Knitting, and Pattern reading.

1777 Larimer St., Ste. 102 (720) 473-2598

Neota Designs—Estes Park

www.neotadesigns.com

Handpainted yarn! 17 colorways in 18 yarn styles, plus alpaca, organic cotton in natural shades.

156 Wiest Dr. (970) 586-8800

Desert Weyr LLC—Paonia

www.desertweyr.com

Black Welsh Mountain fleece, roving, locally produced yarns, and breeding stock. Farm tours by appointment.

16870 Garvin Mesa Rd. (970) 527-3573

CONNECTICUT

Madison Wool—Madison

www.madisonwool.com

A Fiber Lover's Paradise! Fine yarns for handknitting, plus spinning, weaving, and felting supplies. Closed Mondays.

56 Wall St. (203) 245-5921

Mystic River Yarns LLC—Mystic

www.mysticriveryarns.com

Basic to exotic yarns in a pleasant ambiance. Classes, workshops, and personal service by expert knitters.

14 Holmes St. (860) 536-4305

Woolworks Ltd.—Putnam

www.woolworksltd.com

A world of fiber at your fingertips.

154 Main St. (860) 963-1228

Creative Fibers LLC—Windsor

www.creativefibersonline.com

Easy on/off I-91 between Hartford and Springfield. Wide selection for knitting and crochet. Evening and Sunday hours.

645A Poquonock Ave. (866) 669-YARN

DISTRICT OF COLUMBIA

Looped Yarn Works—Washington, D.C.

www.loopedyarnworks.com

A friendly, comfortable, and warm shop with a selection of beautiful yarns and notions. Great classes, workshops, knit-alongs, knit nights.

1732 Connecticut Ave. NW #200 (202) 714-5667

FLORIDA

Uncommon Threads—Palm Harbor

uncommonthreads@tampabay.rr.com

Catering to the fiber arts of knitting, crocheting, weaving, spinning.

31962 U.S. 19 N. (727) 784-6778

A Good Yarn—Sarasota

www.agoodyarnsarasota.com

There's something for everyone at A Good Yarn, Sarasota's ultimate creative spot for all things yarn!

7668 S. Tamiami Trail (941) 487-7914

GEORGIA

Alpaca Yarn USA School of Fiber

www.alpacayarnusa.com

Spin, Weave, Knit, Felt. Classes for Everyone—Alpaca Yarns and Fiber. Largest supplier of equipment in the Atlanta area.

5165 Atlanta Hwy., Ste. 208 (678) 368-4251

Yarn Rhapsody—Gainesville

www.yarnrhapsody.com

Now open! An inspiring selection of yarns and notions with friendly service in a creative atmosphere.

475 Dawsonville Hwy., Ste. C (770) 536-3130

Creative Yarns—Macon

www.creativeyarns.net

Unique and natural yarns for the discriminating fiber fanatic. Spinning, weaving and fibers for felting.

134 Speer Ave. (478) 7GO-KNIT

IDAHO

Alpaca Direct—Hayden

www.AlpacaDirect.com

Huge selection of luxury yarn, roving, and knitting supplies. Classes and support.

1016 W. Hayden Ave. (925) 237-2575

ILLINOIS

Mosaic Yarn Studio Ltd.—Des Plaines

www.mosaicyarnstudio.com

Helpful, knowledgeable staff; unique patterns and yarns, Addi Turbo needles, workshops, special events, classes.

1585 Ellinwood St. (847) 390-1013

Knot Just Knits—Oak Park

www.knotjustknits.com

The new nook for creative knitting, crocheting, and canvas work, no matter what your skill level.

1107-1109 Westgate (708) 948-7943

Wool, Warp & Wheel—Richmond

www.woolwarpandwheel.com

Spinning, weaving, and knitting supplies and equipment. Tue–Fri 7 p.m.–9:30 p.m., Sat–Sun 10–5.
5605 Mill St. (815) 678-4063

INDIANA

Knitting Off Broadway—Fort Wayne

www.knittingoffbroadway.com

Located in a restored 1890's building, this full service yarn store specializes in unique, and hard to find fibers.

1309 Broadway (260) 422-YARN

RiverWools . . . A Knitting Place—Terre Haute

www.riverwools.com

If you knit, crochet, or would like to, you'll love our yarns, tools, books, and classes!

671 Wabash Ave. (812) 238-0090
(866) 889-6657

IOWA

Knitted Together—West Des Moines

www.knittedtogether.com

Enjoy an inspiring collection of yarns, patterns, and classes in a relaxing atmosphere.

7450 Bridgewood Blvd., Ste. 225
(515) 222-YARN

KANSAS

Twist—Wichita

www.twistyarnshop.com

Everything for knit and crochet. Sit and stitch, Wi-Fi, and classes.

607 W. Douglas Ave. (316) 262-9276

KENTUCKY

Sophie's Fine Yarn Shoppe—Louisville

www.sophiesfineyarn.com

Friendly, full-service yarn shop. Come sit and knit!
10482 Shelbyville Rd. Ste. 101 (502) 244-4927

MARYLAND

Vulcan's Rest Fibers—Chesapeake City

www.vulcansrest.com

A source for fibers, yarns, equipment, books, inspiration, and fellowship for spinners, weavers, knitters, and basketmakers. Open every day 10–5.

106 George St. (410) 885-2890

Black Sheep Yarn Shop—Cockeysville

www.blacksheep yarnshop.com

We offer a wide variety of fun yarns and friendly service in a comfortable atmosphere. Enjoy the camaraderie of other knitters/crocheters.

10868 York Rd. (410) 628-9276

Millicent's Yarns & More—Cumberland

www.millicentsyarns.com

Premier yarn shop: one of East Coast's top 10! Easy on/off I-68 in western Maryland. Visit our beautiful NEW WEBSITE!

27 N. Centre St. (301) 722-8100

A Tangled Skein—Hyattsville

www.atangledskein.com

Fine yarns, knitting and crochet supplies, a comfortable atmosphere, friendly people, good advice.

5200 Baltimore Ave. (301) 779-3399

WOOLWINDERS YARN SHOP—Rockville

www.woolwinders.com

Knit, create, and share fine quality yarns and multi-level knitting/crochet classes all in our cozy, friendly shop!

404 King Farm Blvd. (240) 632-9276

MASSACHUSETTS

The Woolpack—Acton

www.woolpackyarn.com

Yearn for Yarn? Unwind your mind and knit yourself silly in our cozy fiber mercantile.

Acton Woods Plaza/340 Great Rd. (978) 263-3131

YARNS in the Farms—Beverly Farms

www.yarnsinthefarms.com

Best of Northshore Boston 2010. Cozy yarn shop and studio in seaside village. Inspiring classes/retreats.

641 Hale St. (978) 927-2108

Stitch House—Dorchester

www.stitchhousedorchester.com

Very cool place to buy yarn, learn to knit, sew, crochet, or have a party.

846 Dorchester Ave. (617) 265-8013

The Fiber Loft—Harvard

www.TheFiberLoft.com

Knitting~Weaving~Spinning~Felting. Serving fiber enthusiasts for over 30 years. We have what you need!

9 Massachusetts Ave. (Rt. 111) (978) 456-8669

The Sheep Shack—Holden

www.thesheepshack.com

Fine yarns, friendly service, classes, rewards program, bargain bin, and the largest selection around.

787 Main St. (508) 829-5811

Webs—America's Yarn Store—Northampton

www.yarn.com

An amazing selection of yarns, super discounts, fast shipping, and simply the best service.

75 Service Center Rd. (800) 367-9327

Cranberry Fiber Arts—S. Hamilton

www.cranberryfiberarts.com

The fiber collection to visit on Boston's North Shore.

161 Bay Rd. (Rte. 1A) (978) 468-3871

Knit Purl—Sudbury

www.knitpurlsudbury.com

A unique yarn boutique. A large selection of quality yarns and knitting supplies. Classes, expert instruction, friendly service.

730 Boston Post Rd. (978) 443-5648

MICHIGAN

Yarn Garden—Charlotte

www.yargardenmichigan.com

Vibrant colors, plush textures, inviting atmosphere, and great customer service. Let your creativity grow with us!

111 W. Lawrence Ave. (517) 541-9323

City Knits—Detroit

www.cityknits.com

The BEST place for yarn. Color nirvana, gourmet fibers, terrific tools! Fabulous location in the Fisher Building. Also in Mt. Clemens.

3011 W. Grand Blvd., Ste. 105 (313) 872-9665

Woven Art—East Lansing

www.yarnandfiberart.com

Classes in knitting, crochet, spinning, and weaving. Excellent selection of artisan and hand-dyed yarns and fibers.

325B Grove St. (517) 203-4467

Yarns & Threads—Lake Linden

www.yarnsandthreads.com

Shepherd's Wool and Firefly needle cases and purses made in Michigan. Large assortment of knitting needles, crochet hooks, notions, and yarn.

332 Calumet St. (866) 296-9568

City Knits—Mt. Clemens

www.cityknits.com

The BEST place for yarn. Color nirvana, gourmet fibers, and terrific tools! One additional location in Detroit.

64 Cherry St. (586) 469-9665

MINNESOTA

All About Yarn—Coon Rapids

www.allaboutyarn.biz

A specialty shop full of gorgeous yarn in a friendly, comfortable atmosphere. Offering classes.

455 99th Ave. NW, Ste. 180 (763) 785-4900

Amazing Threads—Maple Grove

www.amazing-threads.com

Unique yarn, textile, and fiber arts in NW suburbs. Knit and crochet classes.

11262 86th Ave. N. (763) 391-7700

Shelley's Yarns & Fiber Shoppe—Taylors Falls

www.eweyarns.com

Gorgeous natural fiber yarns to inspire! Free shipping on orders of \$75 or more!

406 Bench St. (651) 465-6588

MISSISSIPPI

Knit Studio LLC—Jackson
www.theknitstudio.com

Studio atmosphere with hand-dyed, upscale, natural yarns and fibers as well as nouveau knitting accessories.

1481 Canton Mart Rd., Ste. B (601) 991-3099

Knutty Knitters—Yazoo City

We carry over 60 lines of lovely yarns as well as books, needles, lessons, workshops, fellowship, and great fun.

128 S. Main St. (662) 746-7555

NEW HAMPSHIRE

Elegant Ewe—Concord
www.elegantewe.com

Original designs and exceptional customer service. Featured in *Knitter's Stash* and selected by *Yankee Magazine* as a must-visit destination.

71 S. Main St. (603) 226-0066

The Fiber Studio—Henniker

www.fiberstudio.com

Natural-fiber yarns for knitting and weaving, needles, books, looms, spinning wheels. Our own handpainted yarns.

161 Foster Hill Rd. (603) 428-7830

Inspire 2 Knit & Tea—Plymouth
www.inspire2knit.com

A wonderful yarn shop, an amazing array of fibers and colors! Let us inspire you.

12 Yeaton Rd. (603) 536-KNIT (5648)

Grand View Country Store—Randolph
"A unique yarn shop."

www.grandviewcountrystore.com

All your knitting and crocheting supplies and weekend retreats.

89 U.S. Rt. 2 (603) 466-5715
Out of state (800) 898-5715

NEW JERSEY

Patricia's Yarns—Hoboken

www.patriciasyarns.com

Beautiful natural fiber yarn shop located a stone's throw from Manhattan in the quaint Hudson river-front city of Hoboken.

107 4th St. (201) 217-YARN

Woolbearers—Mount Holly
www.woolbearers.com

Full-service knitting, spinning, weaving, and dyeing shop specializing in handpainted fiber and yarns, spinning and weaving equipment.

90 High St. (609) 914-0003

NEW MEXICO

Miriam's Well—Santa Fe
www.sfschoolofweaving.com

Santa Fe's premier yarn shop. Local, national, and international designer yarns.

614 Paseo de Peralta (505) 982-6312

NEW YORK

Yarn Cupboard—Jamesville
www.yarncupboard.com

Conveniently located 10 minutes from the center of Syracuse. Yarns, patterns/books, notions, buttons, accessories.

6487 E. Seneca Tpk. (315) 399-5148

Lion Brand Yarn Studio—New York
www.lionbrand yarnstudio.com

Wide selection of Lion Brand yarns, free knit and crochet demonstrations, classes, special events.

34 W. 15th St. (212) 243-9070

The Yarne Source—Rochester

www.yarnsource.com

Home of the Knit Parisian Tote and the hottest yarns in cold upstate NY. Remember: We leave no knitters behind.

2080 E. Henrietta Rd. (585) 334-5350

NORTH CAROLINA

Earth Guild—Asheville

www.earthguild.com

Yarns, needles, patterns for knitting. Materials, tools, books, and classes for traditional and contemporary handcrafts.

33 Haywood St. (800) 327-8448

The Tail Spinner—Richlands

www.tail-spinner.com

Complete fiber arts center: Quality yarns, spinning wheels, looms, classes, related tools, and equipment.

109 N. Wilmington St. (910) 324-6166

OHIO

Smith Furnishings—Oberlin

Showcasing fine yarn, books, supplies, and lessons. On the Historic Square in Downtown Oberlin.

25 W. College St. (440) 774-2371

OREGON

Knot Another Hat—Hood River

www.knotanotherhat.com

Your source for everything hip and knit worthy! Find fine yarns, needles, accessories, gifts, and more!

16 Oak St., Ste. 202 (541) 308-0002

Knit Purl—Portland

www.knit-purl.com

A boutique for the avid knitter, located in historic downtown Portland. Our product collection highlights rare and unique treasures from around the world.

1101 SW Alder St. (866) 656-KNIT

Knitting Bee—Portland Westside

www.theknittingbee.com

We LOVE yarn! Friendly customer service and a fabulous selection of yarns for knitting/crochet. 15 minutes west of Portland, off Hwy. 26.

18305 NW W. Union Rd. (503) 439-3316

PENNSYLVANIA

Silverbrook Fiber Arts & Sheepskins
—Marchand

www.silverbrookfiberarts-sheepskin.com

Ten rooms of fiber-arts equipment (knitting, crochet, weaving, spinning) including 4 rooms of yarn in restored 1860 home. Classes. Punxsutawney/Indiana area.

16040 U.S. Hwy. Rt. 119 N. (724) 286-3317

String Thing Shop—Mountain Top

www.stringthingshop.com

Yarn, string, and other fun things. Sit n Knit Wednesday nights. Easy access from I-81 and I-80.

369 S. Mountain Blvd., Unit A2 (570) 474-6542

Natural Stitches—Pittsburgh

www.naturalstitches.com

Best selection of natural fibers in Pittsburgh. Knowledgeable staff. Open 7 days. Evenings, too!

6401 Penn Ave. (412) 441-4410

Glory-ous Knits—Watson town

www.glory-ousknits.com

Top brands; natural, exotic fibers; the best yarns; and more from all over the world.

15 Harris Cir. (570) 437-4139

RHODE ISLAND

Fresh Purls Ltd.—Providence

www.freshpurls.com

A yarn store just for you, offering classes, fine yarns, needles, notions, books, and patterns. Please visit us in the store.

769A Hope St. (401) 270-8220

TENNESSEE

Bliss Yarns—Brentwood

www.blissyarns.com

Just south of Nashville off I-65, you'll find a friendly and helpful staff to assist with all your fiber needs.

127 Franklin Rd. (615) 370-8717

Enchanted Yarn Shop

—Clarksville

www.enchantedyarnshop.com

Offering natural yarns and fibers, spinning wheels, spinning and knitting supplies, and unique handcrafted gifts.

2327 Madison St. (931) 553-9000

Smoky Mountain Spinnery

—Gatlinburg

www.smokymountainspinnery.com

Come shop in our comfortable surroundings. Everything for spinning, weaving, knitting, crocheting, and needlefelting. Antiques and gifts, too.

466 Brookside Village Wy., Ste. 8 (865) 436-9080

TEXAS

Yarntopia—Katy
www.yarntopia.net

Yarntopia carries a multitude of specialty yarns that are sure to please every crafter. Stitching groups and classes available.

2944 S. Mason Rd., Ste. M (281) 392-2386

Rose Path Weaving—Lindale
www.rosepath.net

In east Texas, just off I-20 on Hwy. 69N. High-quality yarn in natural fibers. Skacel and Brittany knitting needles.

2808 S. Main St., #E (903) 882-3234

WC Mercantile—Navasota
www.wcmercantile.com

"The BEST little Wool shop in Texas!" Featuring natural fibers for knitting and spinning. Lots of local Texas yarns, too!

201 E. Washington Ave. (936) 825-3378

The Woolie Ewe—Plano
www.woolie.com

Largest selection of yarn in the Southwest. E-mail info@woolie.com.

1301 Custer Rd., #328 (972) 424-3163

UTAH

Blazing Needles—Salt Lake City
www.blazing-needles.com

Blazing Needles, your friendly Sugarhouse community gathering place. Yarns to inspire. Classes—everyone welcome.

1365 S. 1100 E. (801) 487-5648 (KNIT)

VIRGINIA

fibre space™—Alexandria
www.fibrespace.com

Visit our fresh and funky shop space featuring specialty yarns just outside Washington, D.C.

102 N. Fayette St. (703) 664-0344

The Yarn Lounge—Richmond
www.theyarnlounge.com

A comfortable atmosphere, friendly regulars, helpful staff, and plenty to satisfy your natural fiber needs. It's hip to knit.

3003 W. Cary St. (804) 340-2880

WASHINGTON

NW Handspun Yarns—Bellingham
www.NWHandspunYarns.com

Quality yarns, books, equipment, supplies for the knitter, spinner, and weaver. Classes and gifts. Open 7 days a week.

1401 Commercial St. (360) 738-0167

Paradise Fibers—Spokane
www.paradisefibers.net

Terrific selection of wool yarn, knitting needles, wheels, and looms. Order online or stop in. Same-day shipping!

225 W. Indiana Ave. (888) 320-7746

WISCONSIN

The Dragonfly Yarn Shop—Janesville
www.dragonflyyarnshop.com

Wool and luxury fibers. Addi and Crystal Palace needles. Lessons by the hour. Home of the Pirouette!

1327 N. Wright Rd., Ste. 5A (608) 757-9228

Loop Yarn Shop—Milwaukee
www.loopyarnshop.com

Loop supports all knitters and crocheters in their creative fiber endeavors and aspirations!

2963 N. Humboldt Blvd. (414) 265-2312

WYOMING

The Fiber House—Sheridan
www.thefiberhouse.com

Fleece to fashion and fun! Local alpaca yarn. Books, notions, classes, and 30+ yarn lines! info@thefiberhouse.com.

146 Coffeen Ave. (307) 673-0383

CANADA—BRITISH COLUMBIA

Needle & Arts Centre—Campbell River

www.needleart.com and www.needlearts.blogspot.com

Wide selection of yarns, top consulting, Knit Café, patterns, accessories. Importers of Surina Needles and shawl pins. Mail orders North America.

910 Island Hwy. (888) 588-7834

CANADA—NEW BRUNSWICK

London-Wul Shop/Studio/Farm—Lakeburn

www.thewoolworks.com

Eastern Canada's most complete store for knitters/spinners/weavers. Producers of exquisite fibers and yarns. Canada's Economuseum of Handspinning.

1937 Melanson Rd. (506) 382-6990

CANADA—ONTARIO

the knit cafe—Toronto

www.theknitcafetoronto.com

Original patterns; colorful, natural, local yarns and knitting accessories; one-of-a-kind gifts; and knitting classes.

1050 Queen St. W. (416) 533-5648

ACCESSORIES

THE SHAWL PIN STORE—dozens of styles. Prices start at \$4.59. Beautiful pins in wood, shell, horn, stone, inlay, metal, & more. www.theshawlpinstore.com.

EVENTS

MID-OHIO FIBER FAIR. August 20–21 in Newark, OH. www.midohiofiberfair.weebly.com. Vendors, classes, demonstrations, and raffles.

MINNESOTA KNITTERS' DAYS, October 28–30. Weekend retreat with Candace Eisner Strick. Villa Maria Center, Frontenac, MN. Call Sheryl (651) 388-2905, sherknits@yahoo.com.

NORTH CAROLINA. January 13–15, 2012 Friends & Fiberworks Winter Retreat! Three Spectacular days of everything fiber! Classes and vendors will be posted on our website. www.friendsandfiberworks.com; (828) 633-2500.

WATERLOO COUNTY KNITTERS' FAIR Saturday September 10, 2011, 9:30–4:30. Bingemans, Kitchener; \$6 admission — free parking. Sponsored by K-W Knitters' Guild. Featuring yarns, books, accessories, spinning, seminars, door prizes, fashion show, children's area. Contact — www.kwknittersguild.ca.

INSTRUCTION

WWW.DEGOATSN SHEEP RANCH.COM Bayfield, Colorado; (970) 884-0502. Stay in cabin at beautiful mountain sheep ranch. Spinning and knitting lessons, Wensleydale and mohair fiber available.

KNITTING NEEDLES

SWALLOW CASEIN, KNITTING NEEDLES, "Flexible yet firm, smooth, effortless knitting." Made from milk. Retail and wholesale. (319) 367-5065; clfadw@gmail.com; www.countrylanefiberarts.homestead.com/Home.

TRAVEL

CRAFT CRUISES—Join us on a knitting trip! Alaska, with Jared Flood; Tulips and Windmills, with Myrna Stahman; Musk Ox and Glaciers, with Beth Brown-Reinsel, Donna Druchunas; Scotland, Shetland and Norway, with Joan Schrouder; 35-day Voyage of the Vikings, with Chris Bylisma; Northern Europe and Russia, with Galina Khmeleva, Susanna Hansson, others. Visit www.craftcruises.com or call (877) 97-CRAFT.

TEXTILE TOURS with BEHIND THE SCENES ADVENTURES! Learn traditional knitting/weaving/spinning/dyeing, see indigenous costume: Eastern Turkey, Mali, Burkina Faso, Ghana; India, Peru & Bolivia. See www.btsadventures.com; (510) 275-3662.

TRAVEL NORWAY WITH A NATIVE! June 23–July 8, 2012. For more information call Arnild's Knitting Studio at (515) 451-0584 or go to www.arnhild.com.

UK and IRELAND TOURS & RESOURCES FOR FIBER & FOOD LOVING TRAVELERS. Handcrafted Holidays, (253) 476-3040; handcraftedholidays@yahoo.com; www.handcraftedholidays.com.

WEBSITES TO VISIT

WWW.ABBEYYARNS.COM. 2-ply, worsted-weight yarn, imported from Ireland, sold direct to knitters. Request color card online, view yarn, patterns, kits, buttons.

WWW.WOOL2DYE4.COM Exclusive line of undyed yarns and roving for hand-dyers. Make your work stand out! Wholesale inquiries welcome. Yarnie@Wool2Dye4.com.

Advertisers' Index

2 Ply Productions	129	Glimakra-USA LLC	115	Patternworks/Keepsake Quilting	85
Abstract Fiber	135	Green Mountain Spinnery	129	Pear Tree Fibres PTY LTD	69
Alpaca Yarn Company, The	113	Habu Textiles	136	Personal Threads Boutique	121
Arnhild's Knitting Studio	135	Halcyon Yarn	87	Pollika	136
Ashford Handicrafts Ltd.	87	Harrisville Designs	113, 135	Prism Arts Inc.	97
Aylin's Woolgatherer	129	Hill Country Weavers	117	Purl	41
Becky Caraco Designs	134	Ilga Leja Handknit Design	135	Quayside Publishing Group	91
Bergere de France	21	Indian Lake Artisans	117	Sanguine Gryphon Fiber Arts	113
Berocco	5	Interweave	67, 70, 89, 123, 125, 127, 132, 136, 137, 142	ShibuiKnits	71
Biggan Design Pty Ltd.	119	Jade Sapphire Exotic Fibres	111	Signature Needle Arts	119
Blackberry Ridge Woolen Mill	135	Jimmy Beans Wool	65	Simply Shetland	91
Blue Moon Fiber Arts	65	Jordana Paige	134	Skacel Collection Inc.	6, 95
Blue Sky Alpacas	9	Jul	134	So Vintage Patterns	135
Brooklyn General	91	Just Our Yarn	136	Southeastern Animal Fiber Fair	134
Brown Sheep Company	39	Kaleidoscope Yarns	97	Straker Classics	113
Bryson Distributing (Friendly Products)	97	Kelbourne Woolens (The Fibre Co)	93	Strauch Fiber Equipment Co.	97
Carolina Homespun	115	Knit Kits, Inc.	129	Sundara, Inc.	117
Cascade Yarns	19, 87, 89, 91	Knit Nation	53	Synergo Arts	117
Chic-A	134	Knitting at Knoon Designs	89	Tahki Stacy Charles	3
Classic Elite Yarns	bc	Knowknits	135	Tika Bags	134
Clover Needlecraft Inc.	93	Lion Brand Yarn Co.	47	tilli tomas yarns	95
Coats & Clark Inc.	71	Lisa Souza Knitwear and Dyeworks	136	Tradewind Knitwear Designs	135
Colorful Stitches	111	Loopy Ewe, The	111	Tunney Wool Company / O-Wool	121
Crafts Americana (Knit Picks)	51	Lorna's Laces	119	Universal Yarn	67
Creative Yarns	135	Louet North America	45	Wagtail Yarns	85
Creatively Dyed Yarn	63	Madelinetosh	ifc	Warm Ewe, The	136
Denise Interchangeable Knitting Needles	129	Malabrigo Yarn	49	Washington County Fair, Inc.	135
Earth Guild	136	Mango Moon	95	Washington County New York	95
Eucalan Inc.	93	Mannings, The	117	Weaving Works	129
Fairmount Fibers Ltd.	12-13	Martingale & Co.	69	Web*Sters	111
Favor Software	119	MissBabs: Hand-Dyed Fiber Goods	136	Webs-America's Yarn Store	25
Fiber Producers of Texas, Inc.	134	Misti International Alpaca	115	Westminster Fibers	43
Fiber Trends/Bryson Distributing	115	Mountain Colors Yarns	85	Wool 2 Dye 4	136
Fiddlesticks Knitting	134	New Mexico Fiber Artisans	134	Yarn Lounge, The	129
Finger Lakes Fiber Tour	134	Oat Couture	135		
Fix-A-Stitch	89	Oregon Woodworker, The	134		
Frog Tree Yarns	93	Paradise Fibers	ibc		
Gardiner Yarn Works	135				

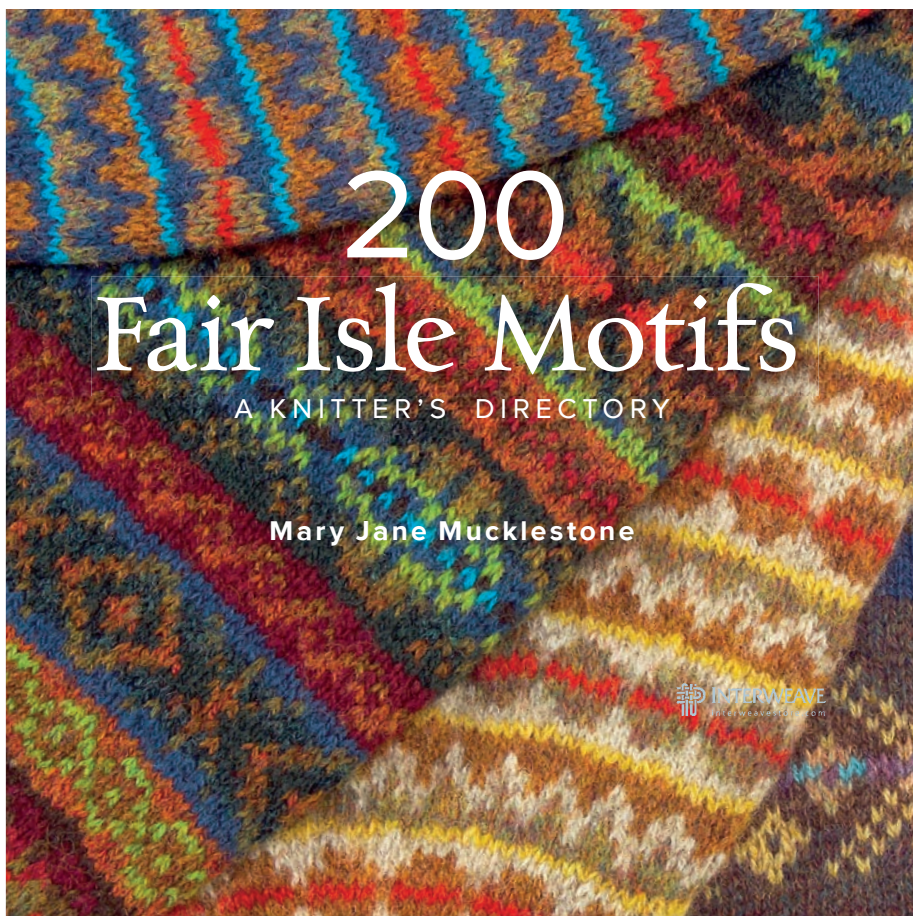

Falling for Fair Isle

Mary Jane Mucklestone's *200 Fair Isle Motifs* offers simple solutions to the seemingly complex technique of stranded colorwork. You'll be an expert motif-maker in no time!

200 Fair Isle Motifs
A Knitter's Directory
Mary Jane Mucklestone
208 pages, 8 3/4 x 8 3/4, \$24.95
ISBN: 978-1-59668-437-9

 **INTERWEAVE**
interweavestore.com

The Elements of Knitting



Cardiff Coat
pages 26, 34

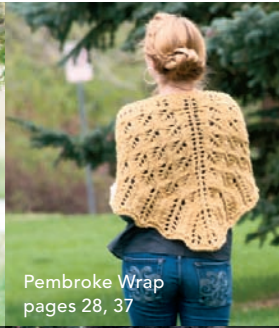

Pembroke Wrap
pages 28, 37

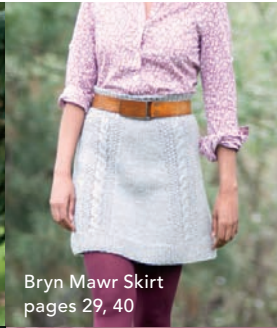

Bryn Mawr Skirt
pages 29, 40

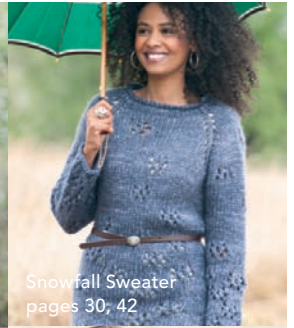

Snowfall Sweater
pages 30, 42

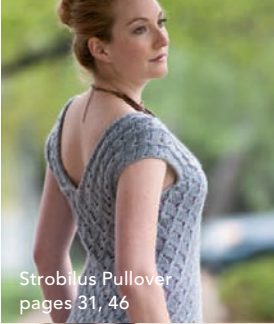

Strobilus Pullover
pages 31, 46



Shadow Tuque
pages 32, 48



Cardigan Bay Jacket
pages 33, 50



KNITTING
interrupted

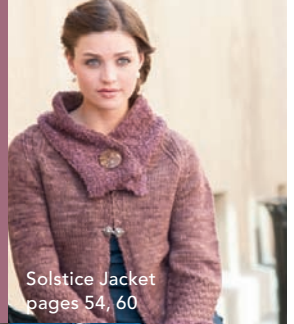

Solstice Jacket
pages 54, 60



Gemini Cardigan
pages 56, 62

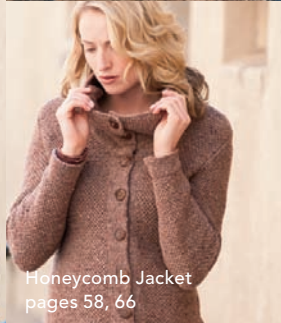

Honeycomb Jacket
pages 58, 66

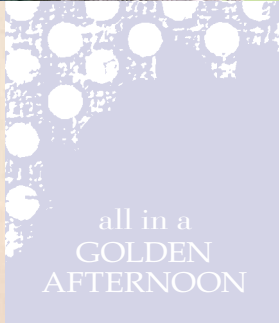

all in a
GOLDEN
AFTERNOON



Dahlia Cardigan
pages 76, 82



Hex Mesh Stockings
pages 78, 86



Fern Lace Stole
pages 80, 92

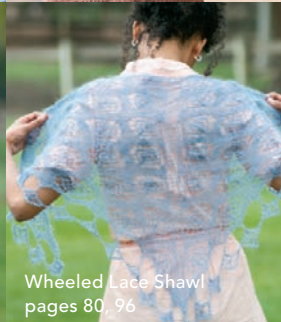

Wheeled Lace Shawl
pages 80, 96



the
Teleidoscope
Turns



True North Mittens
pages 98, 108



Rio Capelet
pages 100, 110



Angel Fire Jacket
pages 102, 112



Canyon Cardigan
pages 104, 118



Border Socks
pages 104, 122

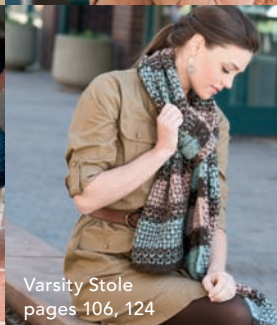

Varsity Stole
pages 106, 124

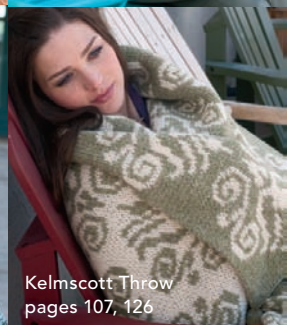

Kelmscott Throw
pages 107, 126

Knitting

BY THE BOOK

MARY KAISER

I've been teaching English to college students for almost as long as I've been knitting. Over the years, I've discovered quite a bit of knitting lore in the classics I read and teach. Given that many published writers in the past were men, it's a little surprising how much knitting you find in the average classic novel or memoir. But in the days when every sock was handknitted, knitting was as much a fact of daily life as a tea kettle on the fireplace hob. Even so, it's easy to tell the difference between the writers who paid attention to knitting and those who were just faking it.

We're all familiar with Madame Defarge in Charles Dickens' *A Tale of Two Cities*, that "dreadful woman" who sits in the corner and grimly knits the names of her political enemies in secret code. But we're never told what she's working on—extra-long gaiters, a muffler, or as she says when asked for an example of what she knits, "shrouds"? Nor do we know anything about her code. Was it a color pattern? It's hard to imagine the dour Madame working a cheerful Fair Isle design. Maybe it was a numerical code, with letters represented by numbers of stitches in a knit/purl sequence. That seems more likely. But why doesn't Dickens explain it? Or, better yet, include her chart for "Charles Darnay"? Sadly, I don't think Dickens was enough of a knitter to care.

Similarly, Nathaniel Hawthorne, in his novel *The Blithedale Romance*, shows that although he may have overheard conversations about sock construction, he has no detailed idea of how to knit a sock. When his elderly character Mrs. Foster knits a sock in her sleep, Hawthorne refers to the process as "footing a stocking out of the texture of a dream." As we all know, you can knit the leg of a simple sock in your sleep, but nobody turns a heel or finishes a toe without tapping into the part of the brain largely reserved for advanced theoretical physics.

To my mind, the male writer who best understood knitting was Leo Tolstoy, who seems to have understood everything. In *War and Peace*, Natasha nurses her fiancé, Prince Andrei, who has been mortally wounded in the Napoleonic War. An aristocratic young woman who hasn't needed the skill before, she takes up sock knitting because "Prince Andrei had told her that no one made such admirable nurses for the sick as old *nyanyas*, who are always knitting stockings, because there is something very soothing in the operation of knitting." Much later, af-

ter grieving for Andrei and recovering, Natasha marries and has children. They beg their nurse for a magic trick:

"Two, two!" shouted the children.

That meant two stockings, which, by a secret process known only to herself, Anna Makarovna knitted at once on her needles, and which she always drew triumphantly one out of the other before the children, when the stockings were finished.

The secret of Anna's stockings is a real pattern, published in an issue of *PieceWork* (January/February 2009). A skilled knitter could actually knit two stockings at once. Tolstoy, who perhaps watched this process as a child, understands that knitting one stocking at a time can be a healing ritual, but knitting two at once is magic.

Women writers who actually knitted stockings are usually much more accurate in their descriptions. And one such description is hair-raising. In her captivity narrative, Mary Rowlandson of Lancashire, Massachusetts, who was held captive by the Powhatan Indians for eleven weeks during King Philip's War in 1675, describes how she survived by knitting socks in exchange for food or for a place to sleep, raveling the stockings of the dead and reknitting them to fit their new owners.

But my favorite knitting passage in modern literature was written by Virginia Woolf, an avid knitter. In her novel *To the Lighthouse*, Mrs. Ramsey, a character based on Woolf's own mother, comforts her young son while she knits a "reddish-brown stocking."

If she finished it tonight, if they did go to the Lighthouse after all, it was to be given to the Lighthouse keeper for his little boy, who was threatened with a tuberculous hip.

The knitting continues through the afternoon, and later that evening Mrs. Ramsey is still knitting while her husband reads his book. She knits and thinks right up to bedtime. The next day, the weather is stormy, and they don't make it to the lighthouse, but the socks, having soothed away tears and tumultuous thoughts, are finished. ■

Mary Kaiser teaches writing and literature in Birmingham, Alabama, where she lives with her husband and two teenage children. She blogs at www.mrsramseysknitting.blogspot.com.

It was th.

Rigid Heddle Weaving
No Experience Necessary
Packages start at \$160



Ball Winder
Works great with
the Super Swift!
\$44.75



Super Yarn Swift V2
With Lantern Moon
Carry Bag \$65.00



\$1000

Win a \$1000 Shopping Spree!
Made with Wool Pak Contest!
Visit our Website for details!
www.paradisefibers.net



Wool Pak is great for felted clogs
and sweaters Starting at \$16.95!

Save money on your next order!

Scan this barcode with your smartphone
for an exclusive deal! You'll need the free
QR reader phone app to access it.



Family Owned
& Operated



1-888-320-7746

Paradise Fibers

paradisefibers.net

Classic Elite Yarns



Waltz Pullover

knit in *Pirouette*

new mohair/bamboo/nylon yarn

Pirouette pattern booklet

classiceliteyarns.com/IWKF11.html

To mail-order *Pirouette* send \$10.95 to:

Classic Elite Yarns

122 Western Ave. Dept: IWKF11

Lowell, MA 01851